

54cm Integrated Column Refrigerator

MODEL AINT5100

ARTUSI
THE ART OF LIVING



36 MONTH
WARRANTY



60CM



LED
LIGHTS



TOUCH
CONTROL



DIGITAL
DISPLAY



ENERGY
RATING



ARTUSI
THE ART OF LIVING
**NOW WITH
5 YEAR
WARRANTY**

SIMPLY REGISTER
YOUR ARTUSI APPLIANCE AT
ARTUSI.COM.AU
COURTESY APPLY

*2+3 Years with product
registration



PRODUCT INFORMATION

FEATURES

- white plastic cavity
- white interior
- Total no frost cooling system
- supplied with right hand hinge
- reversible door
- dBA max noise level - 41
- single compressor
- adjustable temperature levels
- 2°C to 8°C temperature range (main compartment)
- chiller zone
- 0°C to 5°C temperature range
- touch control with LED readout
- Rear wall LED interior panel light
- Lower section LED light
- fixed hinge door system

INCLUDED HARDWARE

- 4 x door shelves
- 4 x removable cavity glass shelves
- 1 x crisper section
- 2 x chiller compartmenten

CAPACITY

- Refrigerator: 280 litres (net)

DETAILED INFORMATION

- Installation kit provided
- Weight: 55kgs (net)
- 220-240V/50Hz
- R600a coolant
- 227kw/yr energy consumption
- 10 amp GPO electrical connection, 3-pin plug
- 1.5m power cord

Standard Option - Product Colour

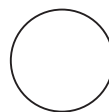

N/A

EAN TBC

AR03092024

DISCLAIMER

Eurolinx & Worldwide appliances Pty Ltd, is continually seeking ways to improve the design specifications, aesthetics and production techniques of its products. As a result alterations to our products and designs take place continually. Whilst every effort is made to produce information and literature that is up to date, this brochure should not be regarded as an infallible guide to the current specifications, nor does it constitute an offer for the sale of any particular product. Product dimensions indicated in our literature is indicative only. Actual product only should be used to define dimension cut outs. Distributors, and retailers are not agents of Eurolinx or Worldwide appliances and are not authorised to bind Eurolinx or Worldwide appliances by any express or implied undertaking or representation.

FOLLOW US ON:  [/artusi_kitchen_laundry_outdoor](https://www.instagram.com/artusi_kitchen_laundry_outdoor)

Australia National Telephone Number 1300 694 583
For showroom opening times, visit our website

[artusi.com.au](https://www.artusi.com.au)

NSW & ACT (Head Office)
48-50 Moore Street
Leichhardt
F 02 8569 4699

Victoria
2r/131 Church Street
Hawthorn

QLD
Contact Head Office

WA & NT
Contact Head Office

54cm Integrated Column Refrigerator

MODEL AINT5100

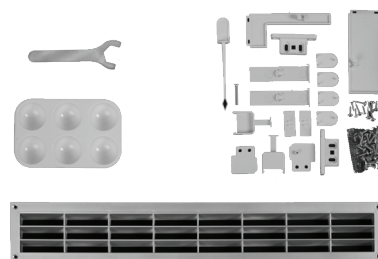
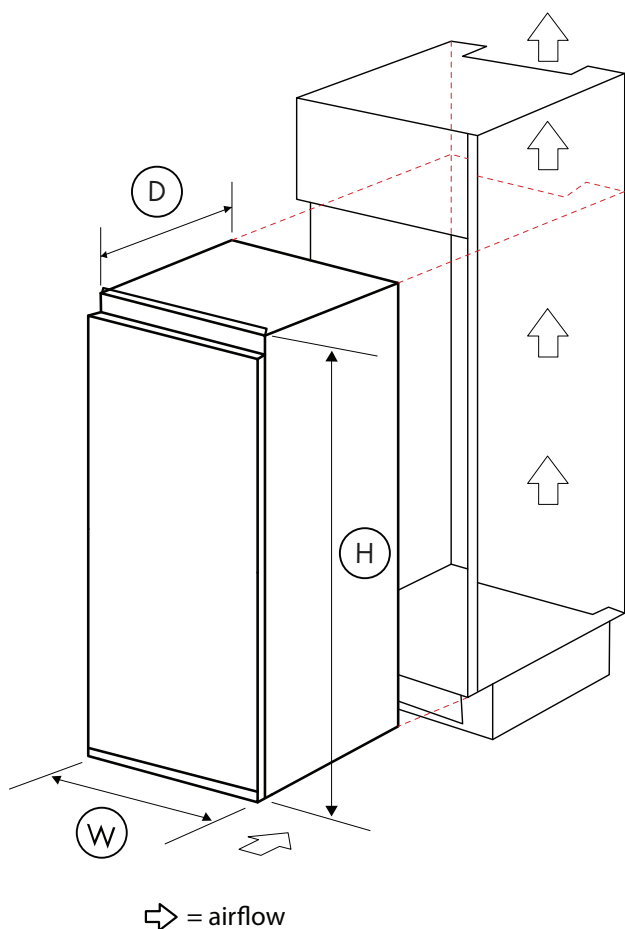

Installation kit

- W 540mm
- H 1770mm (1776 including the fixing bracket)
- D 550mm

NB: drawings are not to scale — for detailed installation instructions, please refer to user guide.

Integrated Refrigeration

Product Size: 540W x 1770H (1776 with top bracket) x 550D

Total Consumption Load: 227kw/yr

10 AMP, 1.5m power cord

AR03092024

EAN TBC

DISCLAIMER

Eurolinx & Worldwide appliances pty Ltd, is continually seeking ways to improve the design specifications, aesthetics and production techniques of its products. As a result alterations to our products and designs take place continually. Whilst every effort is made to produce information and literature that is up to date, this brochure should not be regarded as an infallible guide to the current specifications, nor does it constitute an offer for the sale of any particular product. Product dimensions indicated in our literature is indicative only. Actual product only should be used to define dimension cut outs. Distributors, and retailers are not agents of Eurolinx or Worldwide appliances and are not authorised to bind Eurolinx or Worldwide appliances by any express or implied undertaking or representation.

FOLLOW US ON: [/artusi_kitchen_laundry_outdoor](https://www.instagram.com/artusi_kitchen_laundry_outdoor)

Australia National Telephone Number 1300 694 583
For showroom opening times, visit our website

artusi.com.au

NSW & ACT (Head Office)
48-50 Moore Street
Leichhardt
F 02 8569 4699

Victoria
2r/131 Church Street
Hawthorn

QLD
Contact Head Office

WA & NT
Contact Head Office