

MMW8T20B

20L Turntable Microwave | 800W | Black

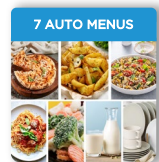
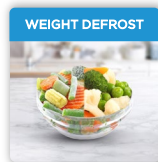

FEATURES	
Colour	Black
Capacity	20L
Wattage	800W
Smart Inverter	No
Display	White LED
Control Interface	Touch
Handle	Integrated
Cavity Colour	Black
Turntable Diameter	255mm
Power Levels	10
No. Of Auto Menu	7
Defrost Modes	Time Weight
Auto Menus	Pizza Potato Rice Pasta Frozen Vegetable Beverage Dinner Plate
Auxiliary Functions	Child Lock Quick Start Eco

MMW8T20B

20L Turntable Microwave | 800W | Black

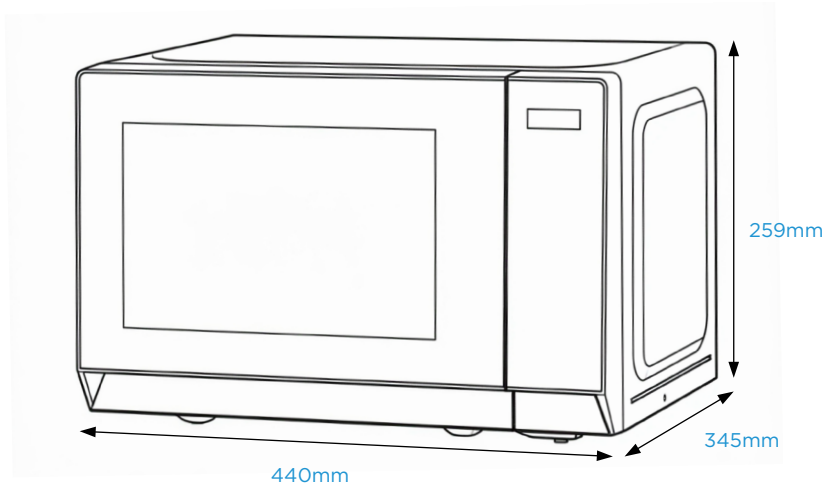

Visit Us

VERSION NO. 20250929

SPECIFICATIONS

Electrical Connection	10A Plug & Lead
Power Input & Supply	1950W 230-240V - 50Hz
Rated Input (Microwave)	1270W
Rated Output (Microwave)	800W
Power Cord Length	1.1m

PRODUCT & PACKAGING INFORMATION

Carton Dimensions W x D x H	503 x 405 x 327mm
Product Dimensions W x D x H	440 x 345 x 259mm
Gross Weight	13.5kg
Net Weight	11kg
EAN	6 944271 687499

WARRANTY

Product	2 Years Parts & Labour
Magnetron	10 Years Parts Only