



INSTANT HOT WATER DISPENSER INSTRUCTION MANUAL

220-240V | 2000-2400W | WHIHWD03SS



CONTENTS

SAFETY INFORMATION

Important Safety Instructions	3 - 4
Electrical Requirements	5

SETUP AND USE

Installation Guide	5
Parts and Features	6
Operation	7

CLEANING AND CARE	8
--------------------------------	---

DESCALING	8
------------------------	---

TROUBLESHOOTING	9
------------------------------	---

CALIBRATION	9
--------------------------	---

WARRANTY	10 - 11
-----------------------	---------

Figures and illustrations in this User Manual are provided for reference only and may differ from actual product appearance.

Product design and specifications may be changed without notice.

IMPORTANT SAFETY INSTRUCTIONS

1. Read all instructions carefully before using your new appliance.
2. Always use this appliance with a power outlet of the voltage (A.C only) marked on the back of the appliance.
3. Always turn the power off at the power outlet before you insert or remove the power plug. Remove by grasping the plug - do not pull on the cord.
4. DANGER: Do not operate this appliance if:
 - i) the cord or plug is split, melted or damaged.
 - ii) the appliance has malfunctioned.
 - iii) the appliance has been damaged in any manner.If any of the above incidents occur, return your appliance to the nearest authorised service center for examination, repair or adjustment.
5. To prevent against fire, do not under any circumstances immerse the power cord, mains plug or appliance body in water or any other liquid.
6. Whilst in operation, use touch panel buttons only as some surfaces may become warm whilst the appliance is running.
7. If the mains supply cord is damaged, it must be replaced by the manufacturer, its service agent or a similarly qualified person in order to avoid a hazard.
8. Close supervision is necessary when the appliance is used near children.
9. Unplug this appliance from mains when not in use and before cleaning. Allow to cool before changing parts, moving the appliance or storage.
10. The use of accessories not recommended for use with this appliance may result in fire, electric shock or personal injury.
11. Do not use this appliance outdoors.
12. Do not allow the cord to hang over the edge of a table, counter top or touch a hot surface.
13. Combustible materials such as paper, curtains, tablecloths, kitchen towels etc should not be placed near the appliance whilst in operation.
14. Do not place the appliance against a wall or against another appliance. Leave at least 5cm free space on the back and sides and 10cm free space above the appliance
15. Do not place the appliance near a hot gas or electric burner or near a heated oven.
16. Do not use this appliance for any purpose other than it's intended use.
17. Do not clean the reservoir or appliance body with chemical cleansers, steel wool pads or other abraisive materials.
18. Keep this appliance and its cord out of reach of children under the age of 8 years old.
19. Wait for the appliance to cool before moving. Carry only by the outer side panels.
20. CAUTION: During operation, hot steam is released through the spout. Keep hands and other body parts away from the spout whilst in operation.

IMPORTANT SAFETY INSTRUCTIONS

21. CAUTION: Allow 30 minutes to cool down after operation before handling or cleaning.
22. This appliance is not intended to be operated by means of an external timer or separate remote-control system.
23. Any appliance that has been dropped or damaged should not be used until examined by an authorised service center.
24. Do not permit the mains supply cord or plug to touch hot objects or allow the power cord to lay across the appliance.
25. This appliance is not intended for use by persons (including children) with reduced physical, sensory or mental capabilities, or lack of experience and knowledge, unless they have been given supervision or instruction concerning the use of appliance by a person responsible for their safety..
26. Do not use harsh or abrasive cleaning agents. The outside surface may be wiped clean with a soft, damp cloth and dried thoroughly. If necessary, a mild dishwashing detergent may be applied to the cloth but not directly applied to the appliance.
27. Children should not play with the appliance.
28. Your appliance should not be unattended whilst in use.
29. This appliance should not be used in a commercial environment such as a restaurant, hotel or hostel dining room.
30. Do not fill the appliance past the max level indicated on water level indicator.
31. Ensure the appliance is placed on a horizontal, even and stable surface.
32. Refrain from placing hot beverages onto cold surfaces.
33. Do not allow the appliance to operate without sufficient water present in the reservoir.
34. This appliance is intended to be used in household and similar applications such as:
 - staff kitchen areas in shops, offices and other working environments;
 - residential farm houses;
 - by clients in hotels, motels and other residential type environments;
 - bed and breakfast type environments.
35. Be cautious of steam whilst the appliance is in operation and shortly after use.

ELECTRICAL REQUIREMENTS

POWER SUPPLY CORD

1. Do not attempt to modify the power cord or plug in any way.
2. A short power supply cord is provided to reduce the risk of becoming entangled in or tripping over a longer cord.
3. If the power supply cord is too short, do not use an extension cord. Have a qualified electrician or serviceman install an outlet near the appliance.

NOTE: Neither Westinghouse nor the retailer can accept any liability for damage to the product or personal injury resulting due to the failing of observing the electrical connection procedures.

INSTALLATION GUIDE

1. Carefully unpack your new appliance.
2. Carefully remove packaging around the appliance and power cord. **Do not remove warning labels.**
3. Complete rinse cycle as as per below: (refer page 6 for control panel diagram)
 - Remove tank and fill to the 2.7L water level. Reinsert tank into the appliance.
 - Press and hold the lock button for around 3-5 seconds to unlock the appliance.
 - Press the Temp. button repeatedly until 000 (degrees) is selected.
 - Press the Volume button repeatedly until 000 (infinite) is selected.
 - (**once 1L of water has been dispensed, press the Start/Stop button to stop flow**)
 - Press Start/Stop and dispense 1L of cold water. Discard dispensed water.
 - Press Temp. button repeatedly until 100 (degrees) is selected.
 - Press Volume button repeatedly until 000 (infinite) is selected.
 - (**once 1L of water has been dispensed, press the Start/Stop button to stop flow**)
 - Dispense remaining water *CAUTION HOT* and discard. Once completed, refill to the 2.7L mark
 - The appliance is now ready for use. Select desired functions to use. (see operation on page 7)

*****NOTE: If error code E7 is shown on the screen, the appliance is indicating a lack of water present in the reservoir. Please ensure there is sufficient water present in the reservoir prior to commencing operation.*****

DANGER: Do not under any circumstances immerse the appliance body, mains cord or mains plug in water or any other liquid.

PARTS AND FEATURES



- | | |
|---------------------------|-------------------------------------|
| 1. Water Tank Cover | 6. Removable Water Tank |
| 2. Control Panel & Screen | 7. Water Level Indicators |
| 3. Spout | 8. Reset Cavity (back of appliance) |
| 4. Main Body | 9. Base |
| 5. Drip Tray | |

RESET KEY:
(refer reset cavity 8)



CONTROL PANEL

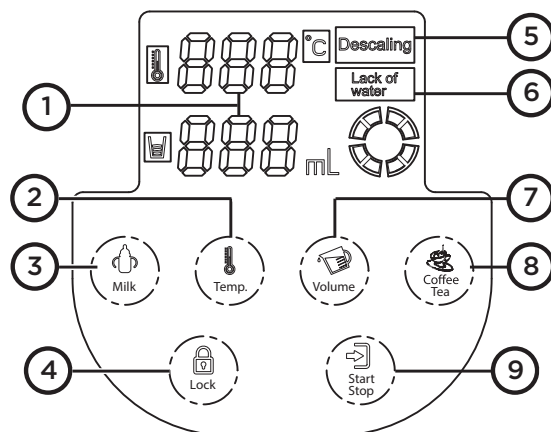

1. LCD Display
2. Temp Button
3. Milk Warm Button
4. Lock Button
5. Descale Reminder
6. Low Water Indicator
7. Volume Button
8. Coffee / Tea Button
9. Start / Stop Button

OPERATION (MANUAL)

*****Always check the reservoir has sufficient water before commencing operation*****

1. As indicated in the installation instructions, please complete the rinse cycle before first use. Refer installation guide on page 5.
2. Place a cup on the removable water tray (5) ensuring the cup aligns with the spout (3).
3. Hold the lock button for 3-5 seconds until the unit unlocks. (When unlocked, the control panel will light up showing multiple presets and functions.
4. Press the Temp. button to select the desired temperature. (000, 45, 55, 65, 75, 85 or 100 degrees celcius approx.
Tip: When set to 000, the unit will dispense water at the temperature of the water in the water tank.
5. Press the Volume button to select the desired volume of water to be dispensed. (100, 200, 300, 400ml or 000 for infinite) Tip: When using infinite, press the Start/Stop button to start and stop the flow of water.
6. Press the Start/Stop button to begin dispensing of the water. To stop at any time, please depress the Start/Stop button to cancel the current operation.

NOTE: As water ambient temperatures fluctuate daily, the volume and temp targets selected can vary +/- 10% hence approximates are specified.

OVERHEAT PROTECTION AND RESET: The appliance is equipped with an overheat protection feature for safety. If the appliance stops operating or no longer boils/heats water, the overheat protection has likely been activated and the appliance may need to be reset. Unplug the appliance from the power source, refill the tank then plug the unit back in. If the unit is still unresponsive use the reset key to reset the appliance and clear the code. Insert the key into the reset cavity (8) to activate the reset and resume operation.

OPERATION (PRESETS)

- **Milk Button:** The milk button is for warming milk bottles only and will heat the water to a temperature of approximately 40 degrees celcius. Do not dispense water directly into a baby bottle and always ensure temperature is tested prior to offering to an infant/toddler.
To use this function, place a suitable collection container onto the removable water tray (5) ensuring the container aligns with the spout (3). Unlock the unit then press and hold the milk button down until the desired amount of water is dispensed. Place the baby bottle with milk / formula premixed into dispensed water to bring milk or formula up to desired temperature.
- **Coffee/Tea Button:** To use this function, place a suitable coffee cup or teacup onto the removable water tray (5) ensuring the container aligns with the spout (3). Unlock the unit then press the Coffee / Tea button. Then unit will display 92 degrees celcius as the default temperature. Select the volume (100, 200, 300, 400ml or 000 for continuous and press the Start / Stop button to begin dispensing water.

CLEANING & CARE

*****CAUTION: Allow 30 minutes to cool down after use before handling or cleaning.*****

CLEANING

1. **WARNING:** Do not under any circumstances immerse the power cord, mains plug or appliance body in water or any other liquid.
2. Ensure unit is unplugged from wall power switch before attempting to clean.
3. The appliance will need descaling on a monthly basis. Please refer below for the descaling process.
4. Do not use harsh or abrasive cleaning agents. The outside surface may be wiped clean with a soft, damp cloth and dried thoroughly. If necessary, a mild dishwashing detergent may be applied to the cloth but not directly applied to the appliance. Do not use abrasive cloths and cleaning materials as they will damage the surfaces of the appliance.
5. Do not place any of the provided accessories into a dishwasher. They are not dishwasher safe.
6. Ensure all items are dried thoroughly after cleaning and placed back into the appliance before storage.
7. Store in a dry place away from steam and humidity where possible.

DESCALING

This appliance is programmed to indicate a descale is required when cumulative use has reached 10 hours. The descaling light will flash on the display to indicate a descale is required.

1. Fill the water reservoir to the 2.7L mark with descaling solution (mixed according to the descaler concentrate instructions).
2. Place a suitable container (2.7L minimum) below the spout, then press and hold the volume button for 3 - 5 seconds to enter the descaling mode. The unit will begin the descaling process by dispensing descaler solution into the container.
3. Once the descaling process has been completed, discard descaler solution, rinse reservoir and dispense 1L of water through the unit normally to flush.

The descaling process is now complete and the unit is ready for use.

TROUBLESHOOTING

BEFORE CALLING FOR SERVICE

If the appliance fails to operate:

1. Check to make sure the appliance is plugged in correctly and securely. If it is not, remove the plug from the outlet, wait 10 seconds and plug it back in securely.
2. Check for a blown or tripped circuit breaker in your home. If these seem to be working correctly, test another appliance in the same outlet to ensure the outlet is working correctly.

IF NONE OF THE ABOVE SOLVES THE PROBLEM, DO NOT TRY TO ADJUST OR REPAIR THE APPLIANCE YOURSELF.

CUSTOMER SERVICE

In the event you believe your appliance to be defective, please return it along with your sales receipt to the place of purchase for resolution.

For any enquiries, please call our service center on: Tel: 1300 883 109
Mon-Fri 8:00am - 5:00pm WST

CALIBRATION / RECALIBRATION

This appliance is equipped with an auto-calibration setting for temperature and volume. To auto-calibrate, please follow the steps below:

1. Fill the water tank to the max level.
2. Place a large container beneath the spout to catch the dispensed water.
3. Press and hold the "Temp" button for 3 seconds - the temperature display will show "AUT" and the flow volume will display "000".
4. Press "Stop/Start" button to commence calibration. The appliance will enter the adjusting mode: from 45-55-65-75-85-100 degrees sequential adjustment and automatically exit after completion.
5. The time taken to complete the process is around 4-5 minutes.

LIMITED WARRANTY

1. Nothing in this Warranty affects the Consumer's rights under the Australian Consumer Law. The benefits to the Consumer under this Warranty are in addition to the rights and remedies of the buyer under any Consumer Guarantees. The Australian Consumer Law requires that we confirm that:

Our goods come with guarantees that cannot be excluded under the Australian Consumer Law. You are entitled to a replacement or refund for a major failure and for compensation for any other reasonably foreseeable loss or damage. You are also entitled to have the goods repaired or replaced if the goods fail to be of acceptable quality and the failure does not amount to a major failure.
2. Subject to Clause 1, the Seller warrants that Westinghouse branded products will be free of manufacturing defects and will perform to the Seller's specifications subject to the following clauses.
3. The benefit of this Warranty extends only to the owner of the property in which the Products manufactured or supplied by the Seller are installed and used by the owner for the duration of the Warranty Period.
4. The Warranty commences on the date of the purchase of the product and continues for the benefit of the Owner for the Warranty Period. If within the Warranty Period a manufacturing defect is discovered in the Product, or the Product fails to perform to the Seller's specifications as a result of some defect in material or workmanship in the Product, then the Seller will at its own discretion:
 - a.) Repair or replace the Product at the cost of the Seller, including but not limited to labour and travel costs. Goods repaired or replaced under this Warranty will be warranted for the remaining period of the Warranty.
 - b.) Refund the purchase price paid by the consumer.
5. The Warranty does not apply to Product that :
 - a.) Has failed due to excessive wear and tear beyond what is considered to be reasonable.
 - b.) Has been misused or neglected.
 - c.) Has been damaged accidentally or by acts of God including fire and flooding.
 - d.) Has been used or operated contrary to operating or maintenance instructions.
 - e.) Has been damaged by the Consumer or a third party authorised to act for the consumer in transit from the Sellers store to the Consumer.
6. In order to make a claim under the Warranty, the Owner must, where possible return the goods to the Seller's store at the Owner's cost. Proof of purchase must be supplied in all cases.
7. The seller will examine any returned Products and if the Seller determines that there is an apparent defect through no fault of the Owner, the Seller will:
 - a.) Make note of the Owner's contact details including the Owner's telephone number which the owner can be contacted during business hours, postal address and e-mail address.

- b.) Make note of the defects reported by the Owner.
 - c.) Take back the defective goods from the owner and determine within a reasonable time through dialogue with the Seller whether the goods are defective.
 - d.) Advise the owner within a reasonable time frame whether it accepts or rejects the Product claim.
 - e.) If the Seller accepts the return of the Product, the Seller must arrange to have
 - i) The Product repaired or,
 - ii) Replace the damaged or faulty Product or,
 - iii) Refund the purchase price.
8. The Seller will not accept any returned Product which has not been returned strictly in accordance with this Warranty.
9. For the purpose of this Warranty:
- a.) Australian Consumer Law means the law as set out in Schedule 2 of the Competition and Consumer Act 2010 (Cth).
 - b.) Consumer means the Purchaser of goods from the seller.
 - c.) Consumer means a Consumer as that term is set out in section 3 of the Australian Consumer Law.
 - d.) Consumer Guarantees means the guarantees under the Australian Consumer Law.
 - e.) Implied terms means any guarantees, conditions, warranties or other terms implied by any Australian Commonwealth, State or Territory laws, (excluding the Australian Consumer Law) or the law of any other jurisdiction.
 - f.) Owner has the meaning set out in clause 3.
 - g.) Warranty means this warranty.
 - h.) Product means the Product/s bought by the Owner from the Seller that fall under this warranty.
 - i.) Warranty Period means:

i) In relation to Cast Iron Cookware:	3 Year Limited Warranty.
ii) In relation to Non-Stick Cookware:	3 Year Limited Warranty
iii) In relation to Cooking Utensils:	3 Year Limited Warranty
iv) In relation to Knives/Knife Block Sets:	3 Year Limited Warranty
v) In relation to Stainless Steel Cookware:	10 Year Limited Warranty
vi) In relation to Chopping boards:	1 Year Limited Warranty
vii) In relation to Small Appliances:	1 Year Limited Warranty



Westinghouse

INNOVATION YOU CAN BE SURE OF



Westinghouse

INNOVATION YOU CAN BE SURE OF

www.westinghousesmallappliances.com.au

CUSTOMER SERVICE - AU: 1300 883 109

info@westinghousesmallappliances.com.au

CUSTOMER SERVICE - NZ: 0508 776 546

info@westinghousesmallappliances.co.nz

IMPORTED AND DISTRIBUTED BY RVM AUSTRALIA PTY LTD.
11 Tamara Drive, Cockburn Central, WA 6164
MADE IN CHINA

© 2020 RVM AUSTRALIA PTY LTD. ALL RIGHTS RESERVED.

® WESTINGHOUSE, and INNOVATION YOU CAN BE SURE OF
are trademarks of Westinghouse Electric Corporation.

Used under license by RVM AUSTRALIA PTY LTD. ALL RIGHTS RESERVED.