

# FULLY INTEGRATED BAR FRIDGE & FREEZER

MODEL AINT119/2

 **ARTUSI**  
THE ART OF LIVING



\*integrated door panel not supplied

## PRODUCT INFORMATION

### FINISH

- white interior

### FEATURES

- Automatic fridge defrost
- Manual freezer defrost
- Adjustable refrigerator temperature
- 1-5 temperature selection range
- power LED cavity light
- 12 hour storage in the event of power failure
- Single compressor
- Static vented cooling system
- Current (A) <10
- Noise: 40db/A

### DOOR

- Supplied with right hand hinge (reversible)
- fixed hinge door system

### CAPACITY & INTERIOR

- 111L total net capacity
- 95L (fridge)
- 16L (freezer)
- 2kg freezing capacity
- 2 x glass shelves (1x split shelf with direct access to crispers)
- 2 x crystal clear door shelves
- 2 x crispers

### TEMPERATURE

- 5 cooling levels (fridge)

### ACCESSORIES

- 1x transparent iceholder tray
- 1x transparent egg tray

EAN 9347777004710

AR14122023

### DISCLAIMER

Eurolinx PTY LTD, is continually seeking ways to improve the design specifications, aesthetics and production techniques of its products. As a result alterations to our products and designs take place continually. Whilst every effort is made to produce information and literature that is up to date, this brochure should not be regarded as an infallible guide to the current specifications, nor does it constitute an offer for the sale of any particular product. Product dimensions indicated in our literature is indicative only. Actual product only should be used to define dimension cut outs. Distributors, and retailers are not agents of Eurolinx and are not authorised to bind Eurolinx by any express or implied undertaking or representation.

**FOLLOW US ON:**  [/artusi\\_kitchen\\_laundry\\_outdoor](https://www.instagram.com/artusi_kitchen_laundry_outdoor)

Australia National Telephone Number 1300 694 583  
For showroom opening times, visit our website

[artusi.com.au](https://www.artusi.com.au)

**NSW & ACT (Head Office)**  
48-50 Moore Street  
Leichhardt  
F 02 8569 4699

**Victoria**  
2r/131 Church Street  
Hawthorn

**QLD**  
Contact Head Office

**WA & NT**  
Contact Head Office

# FULLY INTEGRATED BAR FRIDGE & FREEZER

MODEL AINT119/2

## TECHNICAL DIAGRAM

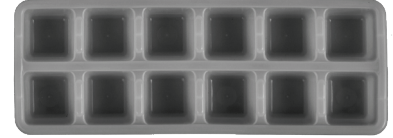
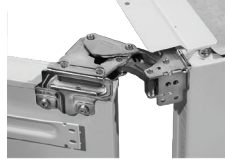

Installation kit

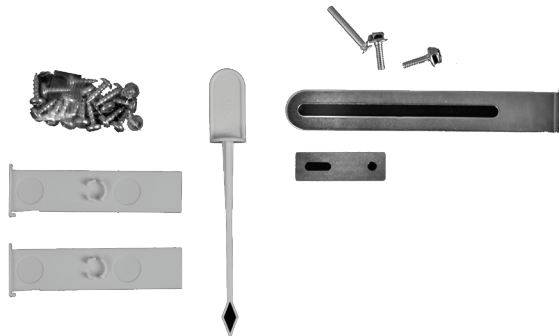

W 596mm

H 818-870mm

D 550mm

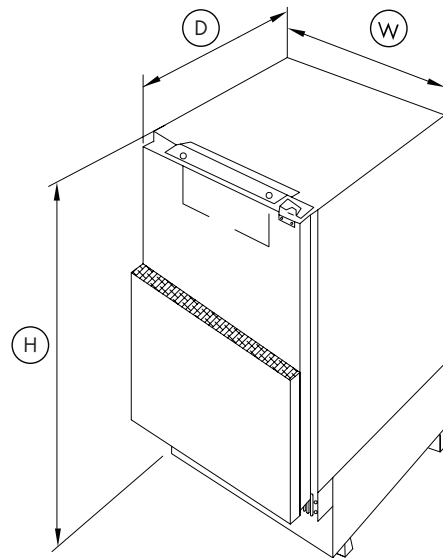

For custom kick panels, a grille with a minimum aperture of 200cm<sup>2</sup> is required

NB: drawings are not to scale — they are to be used for detailed installation instructions, please refer to user guide.

AIN119/2 Fully Integrated Bar Fridge & Freezer  
Voltage (V) 220-240  
Total annual energy consumption 302 (kW/)  
10 AMP plug and cord  
160cm power cord length

**EAN 9347777004710**

AR14122023

### DISCLAIMER

Eurolinx PTY LTD, is continually seeking ways to improve the design specifications, aesthetics and production techniques of its products. As a result alterations to our products and designs take place continually. Whilst every effort is made to produce information and literature that is up to date, this brochure should not be regarded as an infallible guide to the current specifications, nor does it constitute an offer for the sale of any particular product. Product dimensions indicated in our literature is indicative only. Actual product only should be used to define dimension cut outs. Distributors, and retailers are not agents of Eurolinx and are not authorised to bind Eurolinx by any express or implied undertaking or representation.

**FOLLOW US ON:**  [/artusi\\_kitchen\\_laundry\\_outdoor](https://www.instagram.com/artusi_kitchen_laundry_outdoor)

Australia National Telephone Number 1300 694 583  
For showroom opening times, visit our website

[artusi.com.au](http://artusi.com.au)

**NSW & ACT (Head Office)**  
48-50 Moore Street  
Leichhardt  
F 02 8569 4699

**Victoria**  
2r/131 Church Street  
Hawthorn

**QLD**  
Contact Head Office

**WA & NT**  
Contact Head Office