

USER MANUAL

INALTO

INALTO.HOUSE

Top Load Washing Machine

MODEL CODE/S

ITLW55WG

ITLW70WG

ITLW10WG



AUSTRALIAN OWNED

V1.1 0725

Welcome

Congratulations on purchasing your new Washing Machine!

Residentia Group Pty Ltd
ACN. 600 546 656
165 Barkly Avenue
Burnley, Victoria 3121
Australia

—
Applico Ltd
635 Great South Road
Penrose, Auckland 1061
New Zealand

—
InAlto
www.inalto.house
f /inalto.house
@ /inalto.house

The InAlto brand is proudly distributed within Australia by Residentia Group Pty Ltd and within New Zealand by Applico Ltd.

Please refer to the warranty card at the rear of this manual for information regarding your product's parts and labour warranty, or visit online at:

- www.residentia.group
- www.applico.co.nz
- www.inalto.house

Both Residentia Group & Applico are customer obsessed and our Support Teams are there to ensure you get the most out of your appliance. Should you want to learn more about recommended usage, the various features of your appliance, and importantly taking care of the unit when cleaning, our Support Teams are here to help.

Telephone Contacts:

- AU: 1300 11 4357
- NZ: 0800 763 448

It is important that you read through the following use and care manual thoroughly to familiarise yourself with the installation and operation requirements of your appliance to ensure optimum performance.

Again, thank you for choosing an InAlto appliance and we look forward to being of service to you.

SCAN ME

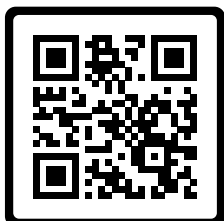

Scan to Register your InAlto Appliance or go to:

- AU: www.inalto.house/en-au/registration
- NZ: www.inalto.house/en-nz/registration

By registering your product, you will receive advanced support, stay updated with the latest from InAlto and find out about new products and promotions.

Contents

02 Welcome

04 Safety Information

07 Your Washing Machine

08 Installation Instructions

11 Operation Instructions

15 Technical Specifications

16 Cleaning & Maintenance

18 Troubleshooting

20 Purchase Details

21 Your Receipt

22 Warranty Information

Customer Care

InAlto recommends the use of original spare parts. When contacting our customer service team on 1300 11 4357, please ensure that you have the following information at hand (which can be found on your appliances' rating plate).

- Model Number
- Serial Number

Safety Information

Important Safety Instructions

WARNING: When using your Washing Machine, follow the precautions listed below:

- Remove all packaging before using the appliance. Otherwise, serious damage may result.
- The washing machine with single inlet valve only can be connected to the cold water supply. The product with double inlet valves should be correctly connected to the hot water and cold water supply.
- Plug must be accessible after installation.
- Installation and repair can only be carried out by a qualified technician.
- This appliance is only intended for use indoors only within a domestic environment.
- This appliance is not intended for use by persons (including children) with reduced physical, sensory or mental capabilities, or lack of experience and knowledge, unless they have been given supervision or instruction concerning use of the appliance by a person responsible for their safety.
- Children should be supervised to ensure that they do not play with the appliance.
- If the power cord is in any way damaged it must be replaced by the manufacturer, its service agent or a qualified and licensed electrician.
- The new hose-sets supplied with the appliance are to be used and that old hose-sets should not be reused.
- The openings must not be obstructed by a carpet.
- Please unplug before cleaning and performing maintenance on the appliance.
- Use a soft cloth moistened with mild soap, and then use a dry cloth to wipe it again.

Model Code	Washing Capacity	Standard Water Pressure
ITLW55WG	5.5kg	0.03MPa~0.8MPa
ITLW70WG	7.0kg	0.03MPa~0.8MPa
ITLW10WG	10.0kg	0.03MPa~0.8MPa

Explanation of the following signal words:

WARNING!

This signal word indicates a potentially dangerous situation which may result in death or serious injuries unless it's avoided.

CAUTION!

This signal word indicates a potentially dangerous situation which may result in slight or minor injuries or damage to property and the environment.

NOTE!

This signal word indicates a potentially dangerous situation which may result in slight or minor injuries.

Electrical Safety

WARNING! POTENTIAL ELECTRIC SHOCK:

- This appliance is for indoor use only.
- Do not position washing machine in a humid location.
- Do not insert your hands into running spin-dry tub.
- If the spin-dry tub does not stop within 15 seconds after opening the cover, please stop using the machine and have it repaired.
- Before performing any maintenance on the device, unplug the appliance from the mains.
- Always unplug the machine and turn off the water supply after use. The max. inlet water pressure, in pascals. The min. inlet water pressure, in pascals.
- To ensure your safety, power plug must be inserted into an earthed three-pole socket. Check carefully and make sure that your socket is properly and reliably earthed.
- Make sure that the water and electrical devices must be connected by a qualified technician in accordance with the manufacturer's instructions and local safety regulations.

Safety Information (Continued)

Risk to Children

- The appliance can be used by children aged from 8 years and above and persons with reduced physical, sensory or mental capabilities or lack of experience and knowledge if they have been given supervision or instruction concerning use of the appliance in a safe way and understand the hazards involved. Children shall not play with the appliance. Cleaning and user maintenance shall not be made by children without supervision.
- Animals and children may climb into the machine. Check the machine before every operation.
- Young children should be supervised that they do not play with the appliance.
- Machine may be very hot during the operation. Keep kids and pets far away from the machine during the operation very wet rooms as well as in the rooms with explosive or caustic gas.

Risk of Explosion

- Do not wash or dry articles that have been cleaned in, washed in, soaked in, or dabbed with combustible or explosive substances (such as wax, oil, paint, gasoline, degreasers, dry-cleaning solvents, kerosene, etc.) This may result in fire or explosion.
- Before hand thoroughly rinse items of washing by hand.

Installing the product

CAUTION!

- This washing machine is for indoor use only.
- It isn't intended to be built-in using.
- The openings must not be obstructed by a carpet.
- Washing machine shall not be installed in bath room or very wet rooms as well as in the rooms with explosive or caustic gases.
- Remove all packaging before using the appliance. Otherwise, serious damage may result.
- The washing machine with single inlet valve only can be connected to the cold water supply. The product with double inlet valves should be correctly connected to the hot water and cold water supply.
- Plug must be accessible after installation.

Risk of Damaging the Appliance

- Your product is only for home use and is only designed for the textiles suitable for machine washing.
- Do not climb up and sit on top cover of the machine.
- Do not lean against machine door.
- Cautions during Handling Machine:
 - The accumulated water shall be drained out of the machine.
 - Handle the machine carefully. Never hold each protruded part on the machine while lifting. Machine door can not be used as the handle during the conveyance.
 - This appliance is heavy. Transport with care.
- Please do not close the door with excessive force.
- Do not wash carpets.

Operating the Appliance

- Before washing the clothes at first time, the product should be operated in one round of the whole procedures without the clothes inside.
- Do not wash flammable and explosive or toxic solvents.
- Do not use gasoline and alcohol etc. as detergents.
- Please only select the detergents suitable for machine washing, especially for drum.
- Make sure that all pockets are emptied. Sharp and rigid items such as coin, brooch, nail, screw or stone etc. may cause serious damages to this machine.
- Please check whether the water inside the drum has been drained before opening its door. Please do not open the door if there is any water visible.
- Be careful of burning when the product drains hot washing water.
- Never refill the water by hand during washing.
- After the program is completed, Please wait for two minutes to open the door.

Safety Information (Continued)

Unpacking

- After unpacking, please dispose of all elements of packaging in a way that will not cause damage to the environment.
- **CAUTION:** During unpacking, the packaging materials (polythene bags, polystyrene pieces, etc.) should be kept out of reach of children.

Disposal of the Appliance

- For disposing of package and the appliance please go to a recycling centre. Therefore cut off the power supply cable and make the door closing device unusable.
- Cardboard packaging is manufactured from recycled paper and should be disposed in the waste paper collection for recycling.
- By ensuring this product is disposed of correctly, you will help prevent potential negative consequences for the environment and human health, which could otherwise be caused by inappropriate waste handling of this product.
- For more detailed information about recycling of this product, please contact your local city office and your household waste disposal service.
- **DISPOSAL:** Do not dispose this product as unsorted municipal waste. Collection of such waste separately for special treatment is necessary.





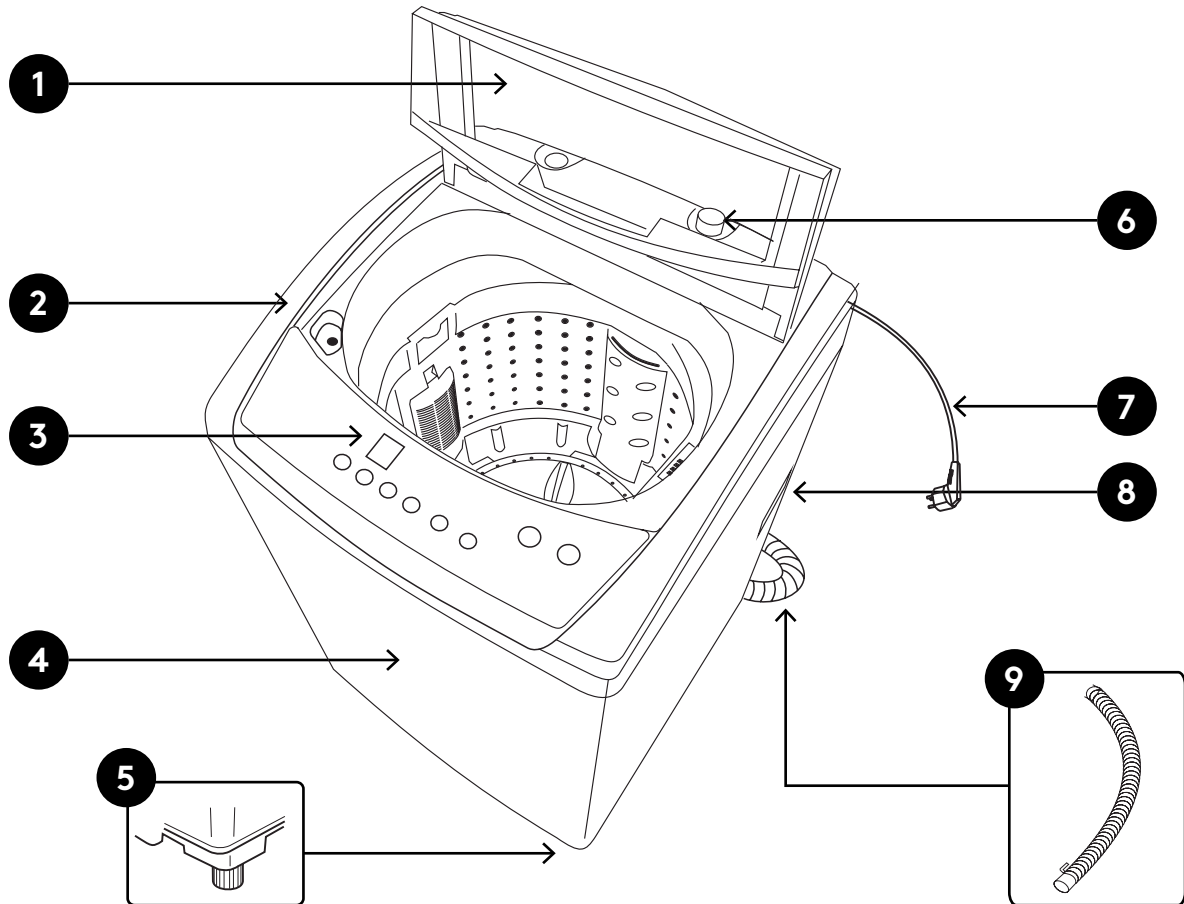

Your Washing Machine

Key

- | | | |
|------------------|--------------------|----------------------|
| 1. Top Lid | 4. Cabinet | 7. Power Cord & Plug |
| 2. Frame | 5. Adjustable Feet | 8. Handle |
| 3. Control Panel | 6. Water Inlet | 9. Drain Hose |

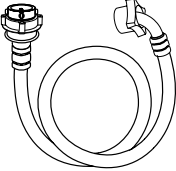
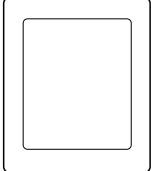

NOTE: The diagrams in this user manual is for explanation purposes only. Your product may appear differently.

Inlet Hose Assembly 	Cabinet Baseboard 	Screw 	Spring Clamp 	Drain Hose 
---	---	---	--	--

Installation Instructions

It's recommended to use the washing machine on its own dedicated power outlet for both convenience and safety. The power outlet must be grounded.

IMPORTANT: If the power cord is damaged, it must be replaced by Residentia Group or one of its authorised service representatives. Please contact 1300 11 HELP (4357) and ensure the appliance is completely disconnected from the power supply.

WARNING!

- Stability is important to prevent the product from moving!
- Make sure that the product should not stand on the power cord.

Positioning Your Washing Machine

When installing the unit, ensure that 20 mm of free space is left at both sides and at the rear of the unit.

Before installing the machine, the location must be:

- Rigid, dry, and a level surface
- Avoiding direct sunlight
- Sufficient ventilation
- Room temperature is above 0 °C
- Kept far away from the heat resources such as coal or gas.

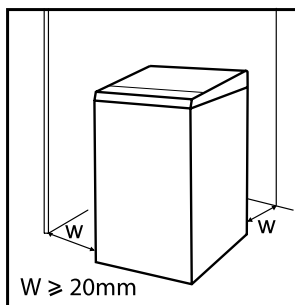

Unpacking The Washing Machine

- **WARNING!** Packaging material (e.g. Films, Styrofoam) can be dangerous for children.
- **WARNING!** There is a risk of suffocation! Keep all packaging well away from children.
- Remove the cardboard box and styrofoam packing.
- Lift the washing machine and remove the base packing.
- Remove the tape securing the power supply cord and drain hose.
- Remove the inlet hose from the drum.

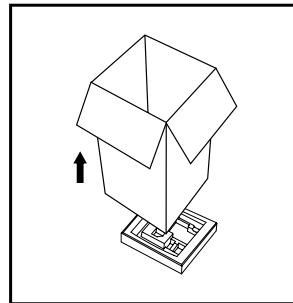

Installing the Drain Hose

- Insert the drain hose to outlet.
- Add the clamping spring.

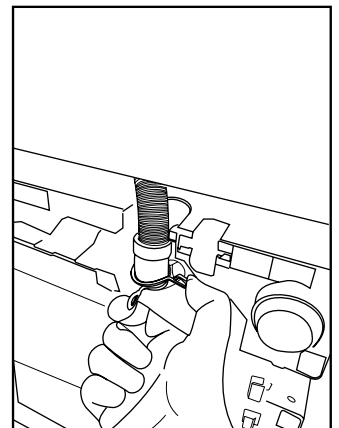
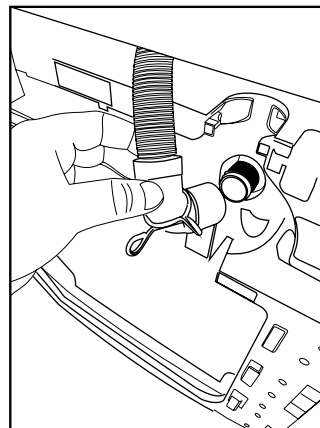

Installation Instructions (Continued)

WARNING!

To prevent leakage or water damage, follow the instructions in this chapter carefully:

- Do not kink, crush, modify, sever or protract the inlet hose or drain hose.
- Position drain hose properly, otherwise damage might result of water leakage.
- If drain hose is too long, do not force it into washing machine as it will cause abnormal noises.

Use an upper drain system to place the end of drain hose:

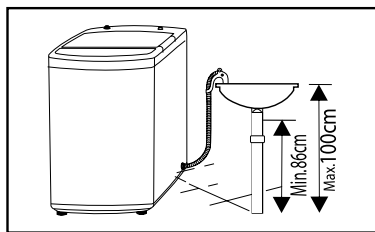
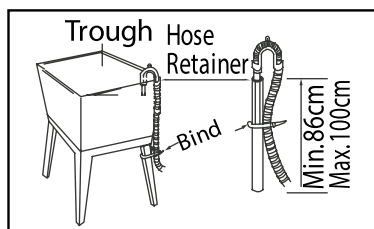
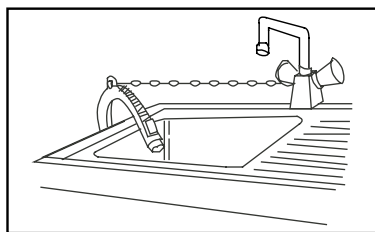

Selection of Tap

Please select appropriate tap

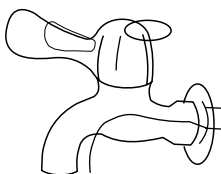

Ordinary faucet

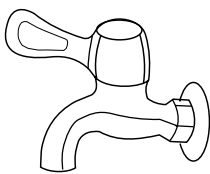

Screw tap

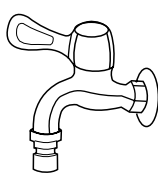

Specialised washing machine tap

Connection of the Inlet Hose, Tap and Washing Machine

Connection between ordinary tap and inlet hose.

1. Loosen the clamp nut until approximately 5mm of thread is visible.

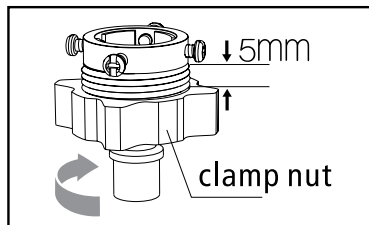

2. Loosen the four mounting bolts on the connector.

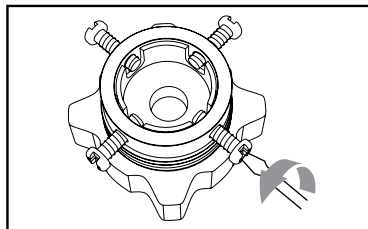

3. Position the connector base over the tap and tighten the bolts evenly to secure it in place.

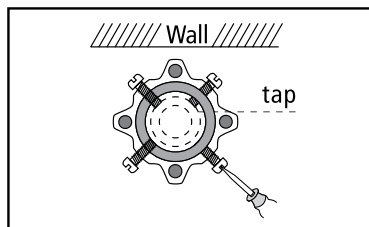

4. Tighten the clamp nut firmly to ensure a secure fit around the tap.

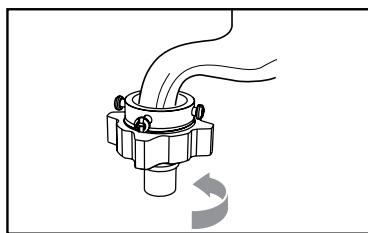

5. Press the slide bushing on the inlet hose and insert the hose into the connector base.

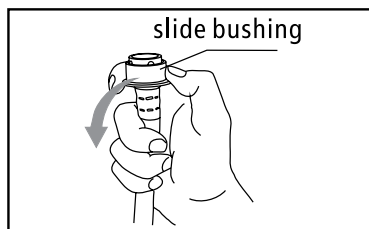

Installation Instructions (Continued)

6. Release the bushing to lock the hose in place.

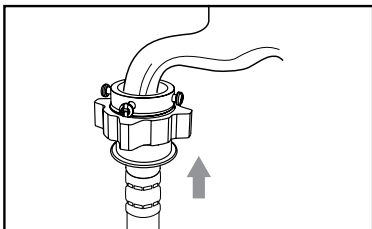

NOTE: After installation, turn on the tap and check carefully for any water leaks at the connection point.

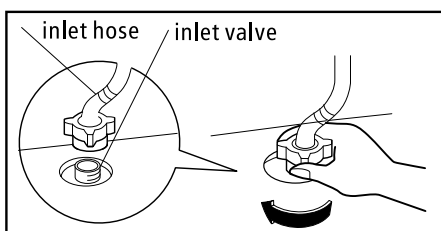

Screw Tap

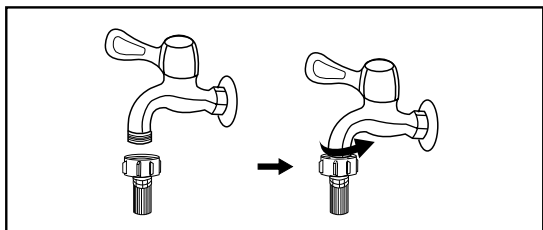

Specialised washing machine tap

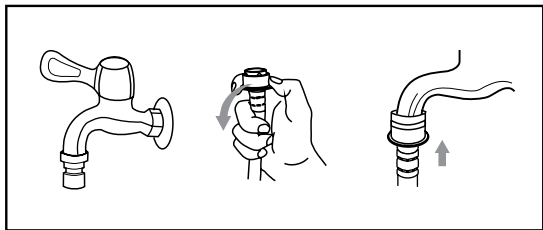

Levelling the appliance

WARNING:

The lock nuts on all four feet must be screwed tightly against the housing.

1. Check if the legs are closely attached to the cabinet. If not, please turn them to their original positions tighten the nuts.
2. Check alignment of the product with a spirit level and if required, correct.
3. Loosen the lock nut and turn the feet until it closely contacts with to the floor.
4. After being locked properly, press four corners again to make sure that they has been adjusted properly.

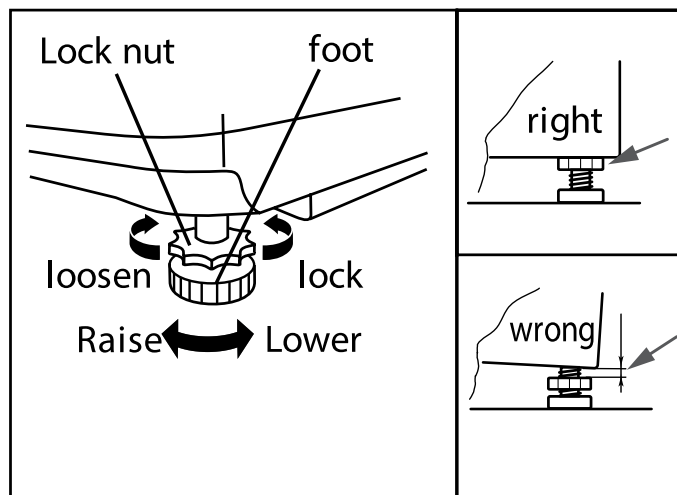

Operation Instructions

Before your Start

- **CAUTION!** Before using the washing machine for the first time, ensure it is installed correctly.
- **CAUTION!** Before using the washing machine for the first time, run a complete wash cycle without any laundry to rinse the drum and internal components.

Getting Started

- Plug in the power cord.
- Turn on the tap to ensure water supply.
- Load your laundry and securely close the door.
- Add detergent to the correct compartment.

Starting the Wash

1. Press the Power button to turn on the machine.
2. Select your desired wash program.
3. Choose the water level if required.
4. Press Start to begin washing.

NOTE: If using the default program, Steps 2 and 3 can be skipped.

After washing

When the wash cycle is complete, the buzzer will sound and the machine will automatically power off. You can then safely remove your laundry.

Important Washing Tips

- The washing machine is designed to operate in environments between 0–40°C. If used in temperatures below 0°C, the inlet valve and drain system may become damaged.
- If the appliance has been exposed to freezing temperatures, allow it to return to room temperature and make sure the hoses are not frozen before use.
- Always check garment labels and follow detergent instructions carefully.
- Use low-foaming or front-loader-specific detergents only.
- **WARNING!** Avoid washing a single item of clothing on its own, as this may cause imbalance and trigger an alarm. For best results, wash at least two or more items together.
- **WARNING!** Do not wash items that have been in contact with flammable substances such as kerosene, petrol, or alcohol.

Detergent Use

- Liquid detergent: Add to the left compartment of the detergent drawer.
- Powder detergent: Add to the right compartment.
- If using thick or clumpy detergents or additives, dilute with a small amount of water before pouring into the drawer. This helps prevent blockages or overflow during water intake.
- Choose a detergent suitable for your selected temperature to ensure effective cleaning while minimising water and energy usage.

Operation Instructions (Continued)



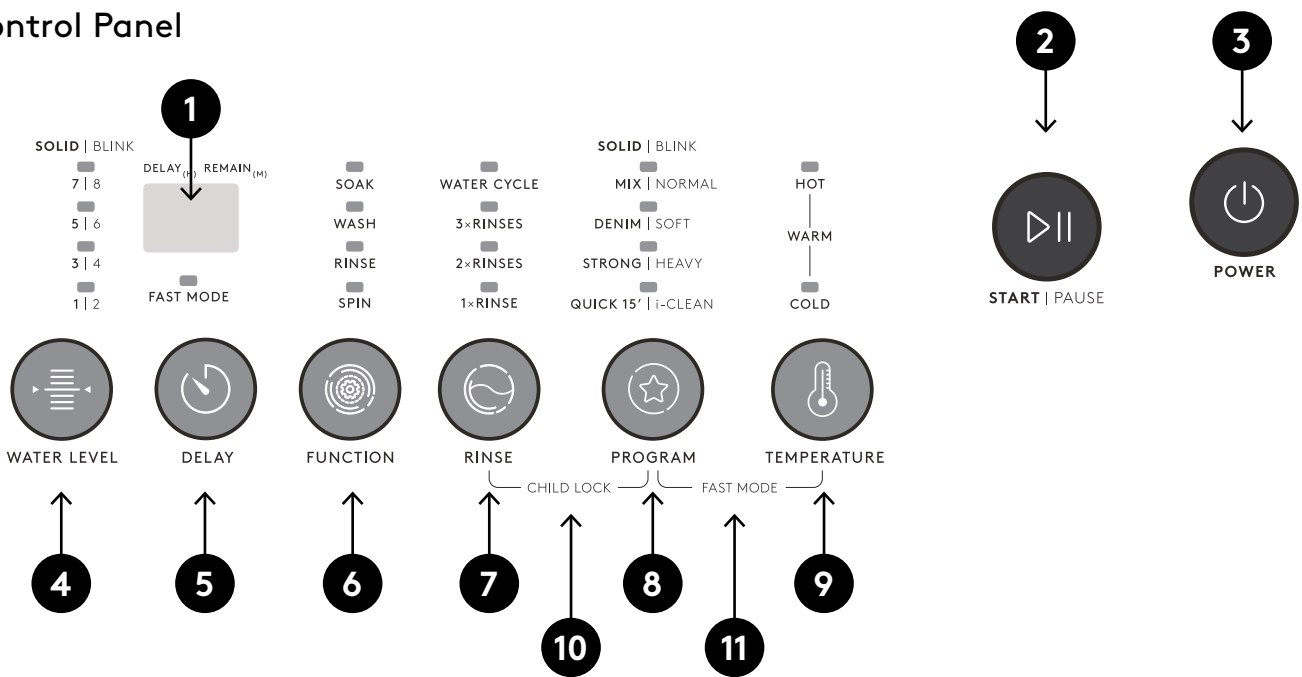

Control Panel



Operating Instructions

Item	Symbol	Description
1 LED Display	N/A	<p>The display shows the settings, estimated time remaining, options, and status messages for your washer. The display will remain on through the cycle.</p> <p>When LED flashing, it means the time that delay to start the machine. When LED lighting, it means the program time that remaining.</p> <p>CAUTION! If there is any break in the power supply while the machine is operating, a special memory stores the selected program and when the power is restarted.</p>
2 Start/Pause	▶	<p>After selecting your desired wash settings, press this button to start your wash cycle.</p> <p>You can also use this button to pause the washing machine during operation.</p>
3 Power	⏻	<p>Press this button to turn your Washing Machine on or off.</p>
4 Water Level	▶ ◀	<p>Select water level according to clothing categories, degree of soiling and washing habits of customers.</p> <p>Press this button to set your Water Level, where 1 is low and 8 is high.</p> <p>A solid indicator light indicates the water levels to the left (1, 3, 5, 7) and a blinking indicator light indicates the water levels to the right (2, 4, 6, 8).</p>

Operation Instructions (Continued)

Item	Symbol	Description
5 Delay		<p>After selecting a Program, press the Delay button to choose a delayed start time. Press Start/Pause to commence the delay operation.</p> <p>To switch the delayed start off, simply press the button until the delay light is off. If the program has already started, press the Power button to reset the program.</p>
6 Wash Functions		Press this button to select your wash function. I.e. Soak, Wash, Rinse or Spin, or a combination of these.
7 Rinse		Press this button to select your desired amount of times to rinse.
8 Program		<p>Press this button to select your wash program type.</p> <p>A solid indicator indicates the programs to the left, whereas a blinking indicator indicates the programs to the right.</p>
9 Water Temperature		<p>Press this button to select your water temperature.</p> <p>When both the Hot and Cold indicators are lit, your washing machine will be set to use Warm water.</p>
10 Child Lock	N/A	<p>Simultaneously press the Rinse and Program buttons to activate the child lock. Repeat this process to deactivate the child lock.</p> <p>NOTE! The Child Lock function will lock all buttons except Power.</p>
11 Fast Mode	N/A	<p>Fast Mode can save between 20-40% of your cycle time by strengthening the washing beats.</p> <p>Simultaneously press the Program and Temperature buttons to activate Fast Mode. Repeat this process to deactivate Fast Mode.</p>

Operation Instructions (Continued)

Washing Programs

Mix

Suitable for everyday loads made from cotton, linen, flax, or jute fabrics.

Normal (Standard)

Ideal for standard laundry made from cotton. Includes one wash, two rinses, and a longer spin cycle.

Denim

Best for heavily soiled and durable garments like jeans and work wear.

Soft

Gentle wash with slower washing and spinning speeds. Designed to reduce wear and minimise fabric deformation –ideal for delicate items.

Strong

Longer wash time and stronger water flow for improved cleaning performance on tougher loads.

Heavy

Designed for heavily soiled and durable garments, similar to "Denim" but with an emphasis on stain removal.

Quick 15'

A fast cycle for lightly soiled or summer clothing. Great when you're in a hurry.

i-Clean

This Drum Cleaning program runs a high-temperature cycle designed to remove detergent residue, dirt, and bacteria buildup from the drum keeping your washer fresh, odour-free, and operating at its best.

NOTE: Regular use extends the life of your machine and ensures your laundry is always cleaned in a healthy environment.

Fast Mode

Fast Mode reduces cycle time by 20–40% by intensifying the washing action.

- To activate Fast Mode:
 - Power on the machine.
 - Select one of the following programs: Normal, Soft, Mix, Strong, or Denim.
 - Press the Fast Mode button combination (Program + Temperature).
- To cancel Fast Mode:
 - Press the same Fast Mode button combination again, or simply power off the machine.

Fuzzy Weighting Function

The washing machine automatically adjusts the water level based on the load size.

IMPORTANT:

- This function is only available when the drum is empty at the beginning of the cycle.
- If you manually select a water level before pressing Start/Pause, fuzzy weighting will be disabled.
- If you press Start/Pause without selecting a water level, fuzzy weighting will activate automatically.
- You can override fuzzy weighting anytime by selecting your preferred water level manually.

Technical Specifications

Product Specifications

Model	ITLW55WG	ITLW70WG	ITLW10WG
Rated Capacity of Wash & Spin	5.5kg (Dry Clothes)	7.0kg (Dry Clothes)	10.0kg (Dry Clothes)
Dimensions (W x D x H mm)	515 x 525 x 910	550 x 570 x 940	601 x 611 x 1015
Height with Lid Open	1223 mm	1340 mm	1413 mm
Weight (Net)	31 kg	38 kg	49 kg
Energy Efficiency Rating (MEPS)	2 Stars	3 Stars	3 Stars
Water Consumption Rating (WELS)	3 Stars	3.5 Stars	3 Stars
Max Washing Noise Level	62 dBA	62 dBA	62 dBA
Max Spinning Noise Level	72 dBA	72 dBA	72 dBA
Power Consumption	1760-2100W	1760-2100W	1760-2100W
Rated Voltage / Frequency	230-240V~ 50Hz	220-240V~ 50Hz	220-240V~ 50Hz
Standard Water Pressure	0.03~0.8MPa	0.03~0.8MPa	0.03~0.8MPa

NOTE:

- This product is subject to continuous improvement, specification are subject to change without prior notice.
- This product was tested in accordance with AS/NZS 2040.2 and AS/NZS6400 using program: Standard, which is the program recommended for a normally soiled cotton load at rated capacity.

Cleaning & Maintenance

WARNING:

Before you begin maintenance, please unplug the machine and close the tap.

External Care

Proper maintenance on the washing machine can extend its working life. The surface can be cleaned with diluted non-abrasive neutral detergents when necessary. If there is any water overflow, use the wet cloth to wipe it off immediately. No sharp items are allowed.

NOTE: Formic acid and its diluted solvents or equivalent are forbidden, such as alcohol, solvents or chemical products, etc.

Cleaning the Inlet Filter

NOTE: Inlet filter must be cleaned if there is less water.

Washing the filter in washing machine:

- Screw off the inlet pipe from the rear of the machine.
- Pull out the filter with long pliers and reinstall it back after being washed.
- Use a brush to clean the filter.
- Reconnect the inlet pipe.

Lint filter clean:

- There is a built-in lint filter in your washer. It can help to collect lint during washing cycle.
- It is suggested to clean the lint filter every 10 cycles.
- Take it out and clean the filter with water. Then place it back into the washer.

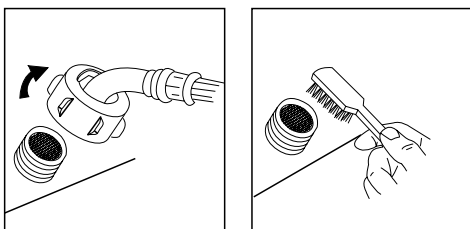

Magic Filter

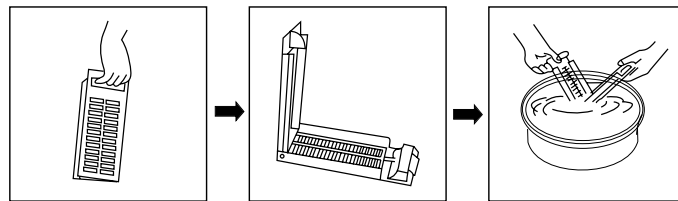

Normal Filter

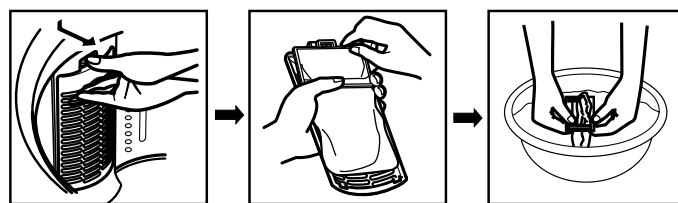

i-Clean

This Drum Cleaning program runs a high-temperature cycle designed to remove detergent residue, dirt, and bacteria buildup from the drum keeping your washer fresh, odour-free, and operating at its best.

NOTE: Regular use extends the life of your machine and ensures your laundry is always cleaned in a healthy environment.

Cleaning & Maintenance (Continued)

Cleaning The Drain Pump Filter (Not Applicable For Model ITLW55WG)

WARNING!

- Be careful of the hot water!
- Allow detergent solution to cool down.
- Unplug the machine to avoid electrical shock before washing.
- Drain pump filter can filter the yarns and small foreign matters from the washing.
- Clean the filter periodically to ensure the normal operation of washing machine.

To clean the drain pump filter:

1. Drain any remaining water from the pump using a shallow container to catch the water.
2. Turn the filter cover counterclockwise to open.
3. Remove any foreign objects from the filter area.
4. Clean the filter thoroughly under water.
5. Reinstall the filter, aligning the raised (convex) section with the pump hole.
6. Tighten the filter cover clockwise until secure.

NOTE: Regularly cleaning the pump filter helps prevent drainage issues and ensures optimal washing machine performance.

CAUTION!

- Make sure that valve cap and emergency drain hose are reinstalled properly, cap plates should be inserted aligning to hole plates otherwise water may leak;
- Some machines don't have emergency drain hose, so step 2 and step 3 can be skipped.
Rotate lower cover cap directly to make water run into basin.
- When the appliance is in use and depending on the program selected there can be hot water in the pump. Never remove the pump cover during a wash cycle, always wait until the appliance has finished the cycle, and is empty. When replacing the cover, ensure it is securely re-tightened.

Troubleshooting

Operation in case of emergency

In the event of an emergency you should:

- Switch off the appliance using the Power button
- Switch the appliance off at the power outlet and immediately unplug.
- Call the Customer Service team on 1300 11 4357 or email support@residentiagroup.com.au

Some minor faults can be fixed by referring to the instructions given in this Troubleshooting section. There is also a self-help section online at <https://support.residentiagroup.com.au>

IMPORTANT: If your appliance appears to be operating incorrectly, then you should disconnect it from your electrical supply and then contact After Sales Support.

WARNING:

- Never dismantle the washing machine.
- Do not attempt to repair the appliance yourself.
- If overflow occurs, turn off the main water supply before calling a service.

Please note that if a technician is asked to attend whilst the product is under warranty and finds that the problem is not the result of an appliance fault, then you may be liable for the cost of the call out charge.

The appliance must be accessible for the engineer to perform any necessary repair.

If your appliance is installed in such a way that an engineer is concerned that damage will be caused to the appliance or your laundry, then they will not complete a repair. This includes situations where the rangehood has been tiled in or sealed in with a sealant.

Please refer to the conditions of that appear on the warranty card at the rear of this user manual.

Error Codes

Code	Possible Cause	Solution
E1	Alarm for abnormal water intake.	Check the water tap is opened or not.
E2	Alarm for water drain has not finished.	Check the water level sensor and drain pump.
E3	Alarm for lid not closed before wash and spin.	Close the lid, Press "Start" button.
E4	Alarm for washing stay at one side.	Manually balance clothes in the barrel by hand.

If problems still occur, please contact the support team with the number at the top of this page.

Troubleshooting (Continued)

Problem	Possible Cause	Solution
Washing cycle won't start	Power is off or the fuse has blown	Check that the power is on and replace the fuse if needed
	Voltage is too low	Ensure your power supply is stable and within the required voltage range
	Not enough water in the drum	Wait for the water to reach the correct level — the washer won't start until it does
	Delay mode is active	Wait for the delay timer to finish, or cancel the delay setting to start immediately
No water coming in	Power is off or fuse has blown	Make sure the machine is plugged in and power is on
	Water supply is turned off or pressure is too low	Turn on the tap fully and check your water pressure
	Inlet hose is not connected properly	Check that the hose is tightly connected and the tap is open
	Inlet filter is blocked	Remove and clean the filter screen inside the water inlet
	Inlet valve may be damaged	A faint clicking sound is normal — if not working, contact service
	Start/Pause button wasn't pressed	After turning the machine on, press Start/Pause to begin the cycle
	Kitchen sink clogged	Check the kitchen sink to make sure it is draining well. If the problem is the kitchen sink that is not draining, you may require a plumber than an appliance repairer.
Water won't drain properly	Drain hose is placed too high	Lower the drain hose so water can flow out properly
	End of drain hose is underwater	Make sure the end of the hose is not sitting in a sink or bucket of water
	Drain pump filter is blocked	Clean out any lint or debris from the filter and hose
Machine won't spin properly	Lid isn't closed properly	Check that the lid is fully shut
	Laundry is unbalanced (all on one side)	Open the lid and rearrange clothes evenly in the drum
	Washer is on an uneven surface	Move the machine to a flat, stable location
	Drive belt may be loose	Contact a technician to inspect or replace the belt

Purchase Details

For future reference, please record the following information which can be found on the rating plate and the date of purchase which can be found on your sales invoice.

STORE DETAILS

STORE NAME | _____

ADDRESS | _____

TELEPHONE | _____ PURCHASE DATE | _____

PRODUCT DETAILS

MODEL NO. | _____

SERIAL NO. | _____

Attach your receipt
to this page



Warranty Information

AUSTRALIAN WARRANTY TERMS AND CONDITIONS

WASHING MACHINES

This document sets out the terms and conditions of the product warranties for Residentia Group Appliances. It is an important document. Please keep it with your proof of purchase documents in a safe place for future reference should you require service for your Appliance.

1. In this warranty
 - (a) 'acceptable quality' as referred to in clause 10 of this warranty has the same meaning referred to in the ACL;
 - (b) 'ACL' means Trade Practices Amendment (Australian Consumer Law) Act (No.2) 2010;
 - (c) 'Appliance' means any Residentia Group product purchased by you accompanied by this document;
 - (d) 'ASR' means Residentia Group authorised service representative;
 - (e) 'Residentia Group' means Residentia Group Pty Ltd of 165 Barkly Ave, Burnley VIC 3121, ACN 70 600 546 656 in respect of Appliances purchased in Australia;
 - (f) 'major failure' as referred to in clause 10 of this warranty has the same meaning referred to in the ACL and includes a situation when an Appliance cannot be repaired or it is uneconomic for Residentia Group, at its discretion, to repair an Appliance during the Warranty Period;
 - (g) 'Warranty Period' means:
 - (i) where the Appliance is used for personal, domestic or household use (i.e. normal single family use) as set out in the instruction manual, the Appliance is warranted against manufacturing defects for 24 months (or 36 months where a valid extended warranty registration has occurred), following the date of original purchase of the Appliance;
 - (h) 'you' means the purchaser of the Appliance not having purchased the Appliance for re-sale, and 'your' has a corresponding meaning.
2. This warranty only applies to Appliances purchased and used in Australia and is in addition to (and does not exclude, restrict, or modify in any way) any non-excludable statutory warranties in Australia.
3. During the Warranty Period Residentia Group or its ASR will, at no extra charge if your Appliance is readily accessible for service, without special equipment and subject to these terms and conditions, repair or replace any parts which it considers to be defective. Residentia Group or its ASR may use remanufactured parts to repair your Appliance. You agree that any replaced Appliances or parts become the property of Residentia Group. This warranty does not apply to light globes, batteries, seals, filters or similar perishable parts.
4. Parts and Appliances not supplied by Residentia Group are not covered by this warranty.
5. You will bear the cost of transportation, travel and delivery of the Appliance to and from Residentia Group or its ASR. If you reside outside of the service area, you will bear the cost of:
 - (a) travel of an authorised representative;
 - (b) transportation and delivery of the Appliance to and from Residentia Group or its ASR, in all instances, unless the Appliance is transported by Residentia Group or its ASR, the Appliance is transported at the owner's cost and risk while in transit to and from Residentia Group or its ASR.
6. Proof of purchase is required before you can make a claim under this warranty.

SCAN ME

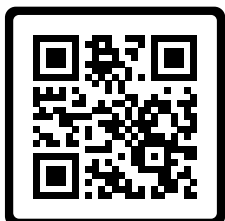

Scan to Register your InAlto Appliance or go to:
www.inalto.house/en-au/registration

By registering your product, you will receive advanced support, stay updated with the latest from InAlto and find out about new products and promotions.

Warranty Information (Continued)

7. You may not make a claim under this warranty unless the defect claimed is due to faulty or defective parts or workmanship. Residentia Group is not liable in the following situations (which are not exhaustive):
 - (a) the Appliance is damaged by:
 - (i) accident
 - (ii) misuse or abuse, including failure to properly maintain or service
 - (iii) normal wear and tear
 - (iv) power surges, electrical storm damage or incorrect power supply
 - (v) incomplete or improper installation
 - (vi) incorrect, improper or inappropriate operation
 - (vii) insect or vermin infestation
 - (viii) failure to comply with any additional instructions supplied with the Appliance;
 - (b) the Appliance is modified without authority from Residentia Group in writing;
 - (c) the Appliance's serial number or warranty seal has been removed or defaced;
 - (d) the Appliance was serviced or repaired by anyone other than Residentia Group, an authorised repairer or ASR.
8. This warranty, the contract to which it relates and the relationship between you and Residentia Group are governed by the law applicable where the Appliance was purchased.
9. To the extent permitted by law, Residentia Group excludes all warranties and liabilities (other than as contained in this document) including liability for any loss or damage whether direct or indirect arising from your purchase, use or non use of the Appliance.
10. For Appliances and services provided by Residentia Group in Australia, the Appliances come with a guarantee by Residentia Group that cannot be excluded under the Australian Consumer Law. You are entitled to a replacement or refund for a major failure and for compensation for any other reasonably foreseeable loss or damage. You are also entitled to have the Appliance repaired or replaced if the Appliance fails to be of acceptable quality and the failure does not amount to a major failure. The benefits to you given by this warranty are in addition to your other rights and remedies under a law in relation to the Appliances or services to which the warranty relates.
11. At all times during the Warranty Period, Residentia Group shall, at its discretion, determine whether repair, replacement or refund will apply if an Appliance has a valid warranty claim applicable to it.
12. Missing parts are not covered by warranty. Residentia Group reserves the right to assess each request for missing parts in a case by case basis. Any parts that are not reported missing in the first week after purchase will not provide free of charge.
13. To enquire about claiming under this warranty, please follow these steps:
 - (a) carefully check the operating instructions, user manual and the terms of this warranty;
 - (b) have the model and serial number of the Appliance available;
 - (c) have the proof of purchase (e.g. an invoice) available;
 - (d) telephone the numbers shown below.
14. You accept that if you make a warranty claim, Residentia Group and its ASR may exchange information in relation to you, in order to enable Residentia Group to meet its obligations under this warranty.

IMPORTANT

Before calling for service, please ensure that the steps in point 13 have been followed.

Contact Service: Please call 1300 11 HELP (4357)

The Australian Consumer Law requires the inclusion of the following statement with this warranty:

Our goods come with guarantees that cannot be excluded under the Australian Consumer Law. You are entitled to a replacement or refund for a major failure and for compensation for any other reasonably foreseeable loss or damage. You are also entitled to have the goods repaired or replaced if the goods fail to be of acceptable quality and the failure does not amount to a major failure.

This page is intentionally
left blank

Warranty Information (Continued)

NEW ZEALAND WARRANTY TERMS AND CONDITIONS

WASHING MACHINES

To help care for your investment, be sure to register your appliance online. Registration will help you if you need to arrange service in the future, and serves as a record of your purchase – including critical information like model number and serial number – that you can refer to at any time.

Simply visit the below website, or ask your retailer for help: www.inalto.house/en-nz/registration

WARRANTY

These products are covered by a warranty for a period of 24 months from the date of purchase, subject to the following conditions*. The warranty covers rectification free of charge of any fault arising from defective materials or components, or faulty workmanship or assembly.

* The conditions above mentioned are:

1. That the purchaser carefully follows all instructions packed with the product;
2. That the purchaser and/or installer carefully follows the installation instructions provided and complies with electrical wiring regulations, gas and/or plumbing codes;
3. That the purchaser carefully follows instructions provided in the owner's handbook relating to the proper use and care of the product and does not use the product for any purpose other than the domestic use for which it has been designed;
4. Commercial use of the product for professional or industrial purposes will void this warranty.;
5. That the product was purchased and installed in New Zealand;
6. That this warranty does not extend to:
 - a) optional glass lids for hobs apart from claims which relate to mechanical or physical damage thereof at the date of purchase;
 - b) 'consumable' parts such as light bulbs or filters;
 - c) damage to ceramic glass caused by liquid or solid spill-overs, lack of maintenance, or impact;
 - d) damage to surface coatings caused by cleaning or maintenance using products not recommended by the owner's handbook;
 - e) defects caused by normal wear and tear, accident, negligence, alteration, misuse or incorrect installations;
 - f) a product dismantled, repaired or serviced by any serviceman other than an authorised service agent;

- g) a product not in possession of the original purchaser;
 - h) damage caused by power outages or surges
 - i) damage caused by pests (eg. rats, cockroaches etc.)
7. That if the product is a freestanding microwave oven or small appliance it must be returned to the dealer/retailer for servicing. These products, unless stated otherwise, have a 12 month warranty from original date of purchase with 24 months on the microwave magnetron; Waste disposers have a 12 month warranty.
 8. The provision of service under this warranty is limited by a 25km boundary from the retailer where the product was purchased except for microwaves. Such travelling outside of these limits will incur commercial cost to be paid by you, regulated by the number of kilometres travelled beyond the 25km limit (50km return trip). Microwaves are to be delivered to the nearest authorised service agent by the customer.

Please refer to your user manual for any further conditions that may apply to your specific model.

Nothing herein contained shall be construed in any way as excluding or limiting your rights under the Consumer Guarantees Acts 1993.

For Service please visit www.applico.co.nz/service or contact the dealer/retailer from whom you purchased the product from or call the 0800 number listed below. If you are unable to establish the date of purchase, or the fault is not covered by this warranty, or if the product is found to be in working order, you will be required to bear all service call charges.

Registration of this warranty constitutes acceptance of the terms and conditions of this warranty.

Should you require any assistance, please call Customer Services on 0800 763 448.

Distributed by Applico Ltd.
www.applico.co.nz
July 2019

After registering your appliance online, we recommend you fill out the below information for your reference and keep this warranty card in a safe place.

THIS WARRANTY IS VALID IN NEW ZEALAND ONLY.

This page is intentionally
left blank

This page is intentionally
left blank

**Elevate
your home,
for less.**

INALTO?

WWW.INALTO.HOUSE



E2447