

# 534L Integrated French Door Refrigerator

## SERIES

Contemporary

## AESTHETICS

White Internal Finish

LED Touch Controls

Stainless Steel Internal Metal Lining

Internal LED Lighting (Fridge & Freezer)

Spill Proof Glass Shelves (Front Side)

Metal Door Bins

## FUNCTIONALITY

Inverter Compressor

Hettich Heavy-duty Door-on-door Hinge

Frost Free

360 Climate Control

Metal Cooling & Pure Air Circulation

Fast Chill & Fast Freeze

Flexible Storage System

Soft Closing Doors

Child Lock Safety

Open Door Alarm

Anti Odour Filter

## ACCESSORIES

Drawers: 2 (Fridge), 2 (Freezer)

Shelves: 4 (Fridge)

Door Bins: 6 (Fridge)

## STORAGE CAPACITY

Total Capacity 534L

Fridge Capacity 333L

Freezer Capacity 183L

Variable Zone Capacity 18L

## TEMPERATURE RANGE

Fridge 2°C to -8°C.

Freezer -15°C to -23°C.

Variable Zone -4°C, 0°C, 4°C

## FUNCTIONS

Fast Chill 150 mins

Fast Freeze 24 hrs

## MAX NOISE LEVEL

Quiet 38 dB(A) Operation

## SIZE, W/D/H (MM) \*Includes Feet Height

Packaged: 1035 × 653 × 2078

Physical: 962 × 572 × 1996\*

## WEIGHT (KG)

Net: 149

Gross: 173

## INSTALLATION

Built-in Installation

Door Open Angle: 115°

Door Open Width: 1380 mm

## CONSUMPTION

Energy Rating (MEPS) 5.5 Stars

Energy Consumption 300 kWh/year

## POWER REQUIREMENTS

Power Connection 10 Amp, Plug

Rated Voltage 220–240V~, 50Hz

## ADDITIONAL DETAILS

Barcode 9349260095106

Warranty 3 Years

Compressor 10 Years



## FRONT VIEW

Note: See the user manual for detailed ventilation and installation details

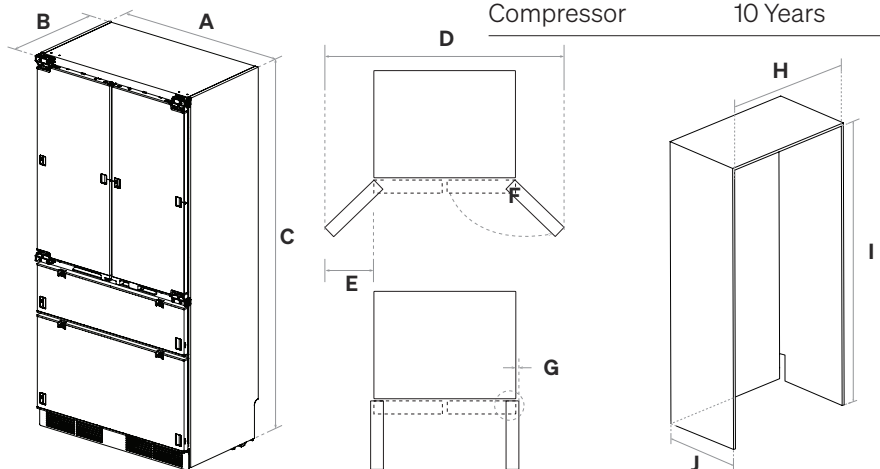

## DIMENSIONS (MM)

A	962	B	572	C	1996	D	1380	E	212
F	115°	G	3	H	964	I	2000	J	580