

HITACHI



# Hitachi Washing Machine Freestanding

Intelligent Series

The Art of Ease

Product Code BD-120XKVEADM



Intelligent cleaning for busy lives

## Intelligent Wash

With this intelligent combination of **load detection**, **sensor-based analysis**, **automatic dosing**, and adaptive movement, the washing machine delivers a truly **optimized wash cycle** every time. It ensures perfect cleaning, efficient resource use, and **maximum fabric care**, so your clothes look and feel their best—wash after wash.

The **dirt and rinse sensors** are designed to optimize the washing process by detecting the level of soil on your load during the **Auto Program** cycle. The dirt sensor measures the amount of dirt or soil in the wash water and adjusts the **wash time, water usage and detergent levels** to ensure optimal cleaning. The rinse sensor detects how clean the water is during the rinse cycle and ensures that clothes are thoroughly rinsed without excess detergent left behind meaning your clothes are cleaned to perfection.



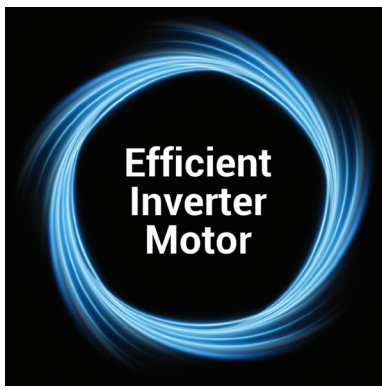

## Inverter Motor

Hitachi Washing Machines with inverter motor technology provide high efficiency, high durability, and low noise levels. Inverter motors outperform non-inverter motors by 25%\*.

## Hygiene Program

The program works by releasing the steam from the bottom of the washing machine's drum, right before it even starts washing. Creating a pre-treatment to loosen up stubborn stains, dirt, and other gunk in your garments.



## Refreshing Steam Program

Refreshing Steam is a short program for 1kg dry clothes. This program makes your ironing duties easier while also refreshing odour on your clothes.

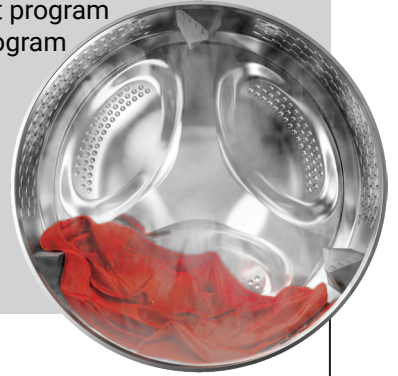

## Wifi Connectivity

Control your laundry remotely. Control and monitor your Hitachi washing machine from anywhere with Homewhiz; a smart home application that provides a professional assistant to make your life easier!



## Aquastop

Protect your laundry from flooding with Aquastop safety valve installed on your washing machine.



## Tub Clean

Keep your washing machine performing well with the Tub Clean function. Use regularly to look after your washing machine.



## Drum Light

Hitachi's interior LED light makes loading and unloading your laundry easier; by lighting up the inside of the drum, it helps you easily spot those smaller items that may get left behind.

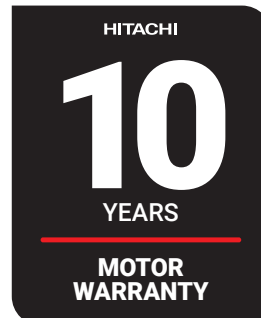

\* Comparison is based on performance rating with respect to induction motor under similar load conditions.

\*\*Certified with Allergy UK that the features helps reduce the amount of allergens in your laundry including cat, dog and pollen allergens, as well as bacteria and fungi.

# Specification



<b>Model</b>	BD-120XKVEADM	
<b>Type</b>	Freestanding Washing Machine	
<b>Capacity</b>	Washing Capacity	12 kg
<b>General</b>	Colours Available	Volcanic Grey
	Interface	Touch LED Display
	Max Spin Speed (RPM)	1400
	Inverter Motor	●
<b>Performance</b>	Water Consumption per wash	104 L per wash
	WELS Registration No.	C02384
	WELS Water Rating	4.5 Star
	Energy Consumption	386 kWh per year
	Energy Rating	4.5 Star
<b>Features / Functions</b>	Waterfall Spray	●
	Single Water Inlet (Cold)	●
	Dirt Sensor	●
	Add Garment Option	●
	Remaining Time Indicator	●
	Time Delay	●
	Drum Light	●
	Aquastop+	●
	Steam Function	●
Autodosing Detergent & Softener	●	
<b>Programs</b>	Number of Programs	14
	1	Cottons
	2	Cottons Eco
	3	Synthetics
	4	Rapid/Rapid14
	5	Wool
	6	Shirt
	7	Download Program
	8	Spin+Drain
	9	Rinse
	10	Tub Clean
	11	Bedding
	12	Hygiene
	13	Refreshing Steam
14	Auto Program	
<b>Download Programs</b>	1	Stain
	2	Outdoor/Sports
	3	DarkWash/Jeans
	4	Towel
	5	Soft Toys

- Specifications and designs are subject to change without notice.
- Colour tone of actual products may differ from those shown.
- Feature images are for illustrative purposes only, they may not reflect the actual product.

# Specification

Model		BD-120XKVEADM
		Freestanding Washing Machine
Auxiliary Functions	1	Remote Control (Wifi)
	2	Steam
	3	Extra Rinse
	4	Speedy/Intensive
	5	Powder Detergent / Softener Dosage
	6	AntiCrease+
	7	Child Lock
Autodosing System	Liquid Detergent Dosing	●
	Liquid Detergent Dispenser Capacity	1.0 L
	Fabric Softener Dosing	●
	Fabric Softener Dispenser Capacity	500ml
	Low Level Notification	●
	Adjustment Levels	●
	Sku	7177884700
	EAN	8690842697494
	Warranty	5 Years Manufacturers Warranty
	Matching Dryer	TD-90XKVEUVM
	Compatible Stacking Kit	NBSKWS60M
Dimensions (mm)	Width	600
	Depth	630
	Height	845
Weight (Net/Gross, kg)		84.0 / 87.0

## Installation Diagram

D	Z	L	H	A	C	G	P	M	N	S	Units
596	845	1066.2	27.5	516.3	33.5	53.5	24.2	496.4	630.8	1099.7	mm

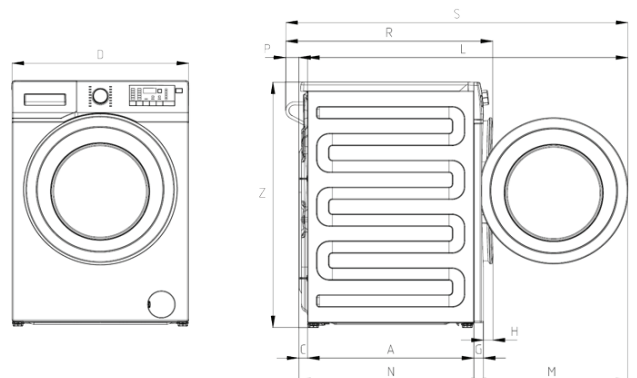

## Matching 9kg Heat Pump Tumble Dryer | TD-90XKVEUVM



- 9kg capacity
- 14 programs
- 9 star energy rating
- UV technology
- Inverter motor (silent & wool programs)
- Hygiene program
- Double layer door filter
- Reversible door
- Drum light
- Wifi Connectivity (download programs)
- HxWxD(mm): 845 x 600 x 674

## Compatible Stacking Kit | NBSKWS60M

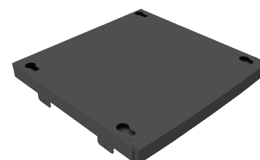

- 60cm Depth
- Stacking Kit with Shelf
- Easy Installation
- 40cm shelf when pulled out
- Shelf holds up to 20kg
- HxWxD(mm): 60 x 600 x 600

- Specifications and designs are subject to change without notice.
- Colour tone of actual products may differ from those shown.
- Feature images are for illustrative purposes only, they may not reflect the actual product.

**Beko A&NZ Pty Ltd**  
**Official Distributor of Hitachi Home Appliances**

55 Blanck Street, Ormeau QLD 4208  
[www.hitachi-homeappliances.com/au-en](http://www.hitachi-homeappliances.com/au-en)