

Designed to Enhance

EST. 1981

omega

Installation + User Manual

OCG604WX / OCG705WX / OCG905WX /
/ OCGG604WB / OCGG905WB

Gas Cooktops

60, 70 & 90cm

Contents

03	Welcome
04	Safety Information
06	Installation Instructions
13	Technical Specifications
18	Cooktop Overview
20	Operating Instructions
22	Care & Maintenance
24	Purchase Details
26	Warranty Information

Welcome

Residentia Group

Office 165 Barkly Avenue Burnley
Victoria Australia 3121

ACN 70 600 546 656

Online residentia.group
omegaappliances.com.au

Post PO BOX 5177 Burnley
Victoria Australia 3121

Phone 1300 11 4357

Email support@residentia.group

Congratulations on purchasing your new cooktop.

Omega appliances are proudly owned and distributed within Australia by Residentia Group Pty Ltd.

Please refer to the warranty chapter at the rear of this manual for information regarding your product's parts and labour warranty, or visit us online at:

→ residentiagroup.com.au

Here at Residentia Group, we are customer obsessed and our Support Team are there to ensure you get the most out of your appliance. Should you want to learn more about your unit, and importantly, taking care of the appliance, our Support Team are here to help. You can use our online Support Centre at any time by visiting:

→ support.residentiagroup.com.au

Or you can contact us by dialling: 1300 11 HELP (4357)

It is important that you read through the following user manual thoroughly, in order to familiarise yourself with the installation and operation requirements of your appliance, and to ensure optimum performance.

Again, thank you for choosing an Omega appliance and we look forward to being of service to you.

Kind Regards,

The Residentia Team

Customer Care

At Residentia Group, we strongly encourage the use of authentic spare parts to guarantee the best results. When contacting our spare parts team through 1300 11 HELP, or by emailing parts@residentiagroup.com.au, ensure that you have the model and serial numbers on hand, which are found on your appliances' rating plate.

Safety Information

Important Safety Instructions

This cooktop must only be installed by a suitably licensed and qualified installer in accordance with the instructions provided. Incorrect installation may result in bodily harm, damage to property, and void the product's warranty.

- This appliance is intended for domestic use only, and must only be used for food preparation.
- Do not use this appliance for anything other than its intended purpose. Other uses are not recommended, and may cause fire, electric shock or personal injury.
- The use of attachments is not recommended by the appliance manufacturer and distributor as they may prove hazardous, or cause damage to your appliance.
- Ensure you remove all the packaging, taking care to discard waste responsibly.
- Under absolutely no circumstances should you install or use a damaged appliance.
- Always move the appliance carefully.
- The appliance must always be installed by an authorised technician or similarly qualified person. Please note that the manufacturer is not held responsible for any damage caused by defective placement or installation done by an unauthorised personnel.
- To arrange an authorised technician please contact our friendly support team at 1300 11 HELP (4357).
- **CAUTION:** The appliance must be earthed.
- Ensure the data on the cooktop's rating label agrees with the power supply. If not, contact an electrician.
- Always use a correctly installed shockproof socket. Do not use any multi-plug adapters or extension cables.
- Connect the mains plug to the mains socket only at the end of the installation. Make sure that there is access to the mains plug after the installation. Do not connect the appliance plug with a power connection board.
- Do not pull the mains cable to disconnect the appliance. Instead pull the plug portion of the mains cable.
- Never touch the mains cable or plug with wet hands, nor should you touch the oven with wet hands or feet.
- **WARNING:** If the supply cord is damaged, it must be replaced by the manufacturer or its service agent.
- **WARNING:** All electrical work must be done in accordance with local and national electrical codes as applicable and should be undertaken by licensed and qualified persons only. Failure to follow these instructions can result in death, fire or electrical shock.
- The manufacturer is not responsible if incorrect installation or use causes injuries and damages.
- Before installing and using your appliance, carefully read the supplied instructions. Always keep the instructions with you for future reference.
- Adults and children must not operate the appliance without supervision if they do not have the physical or mental ability, or if they lack the knowledge and experience required to operate the appliance correctly.
- Never allow children to play with the appliance. Do not allow children to go near the cooktop while it is operating without supervision, children must always keep a safe distance from the appliance at all times.
- Under absolutely no circumstances should cleaning and user maintenance be carried out by children.
- This appliance can be used by children aged from 8 years and above and persons with reduced physical, sensory or mental capabilities or lack of experience and knowledge if they have been given supervision or instruction concerning use of the appliance in a safe way and understand the hazards involved.
- The appliance and its accessible parts become hot during use. Care should be taken to avoid touching heating elements or placing objects by the cooktop, especially while it is in operation, as it may be dangerous.
- If the burners are in operation for a prolonged period of time, the space between them can also become hot.
- Please follow the manufacturer's instructions when using certain cookware. Aluminium foil and plastic containers can melt and stick on hot burners.
- Never operate the cooktop when there is nothing on top. Do not heat empty pots or pans, as this will damage the pan's base. Do not allow saucepans to boil dry, in particular enamel and aluminium saucepans.
- The base of the cookware used for the cooktop must be clean, dry and flat, as uneven surfaces can affect the cooking process or damage the burners' surface.
- Metallic objects such as knives, forks, spoons and lids should not be placed on the cooktop as they can get hot.

Safety Information

- Do not use a roasting dish that is so large it has to be heated using two burners, as this will cause too much heat to accumulate, damaging your appliance.
- Before cooking, always ensure that burner bodies and trivets are properly located on the cooktop (i.e. correctly assembled and positioned).
- Never leave or store flammable objects on or near the cooktop. It is suggested to store cooking oils in a cupboard away from the appliance.
- Overheated oil or fat can ignite very quickly. Never leave fat or oil to cook unattended. Should the oil ignite, do not try and put it out by pouring water on it. Cover the pan immediately with a lid or plate, and switch off the cooktop. Let the cookware to cool down on the cooktop before removing.
- Be careful with food that is prepared using drinks with a high alcohol content, such as wine, rum or cognac. Alcohol evaporates at high temperatures, and in some circumstances the alcoholic vapors can catch fire. Only use small quantities of drinks with a high alcohol content.
- Prolonged and intensive use of the appliance may call for additional ventilation, for example the opening of a window, or increasing the power level of your rangehood.
- **WARNING:** Incorrect repairs are dangerous. Repairs may only be carried out by an authorised service technician or a similarly qualified individual.
- **WARNING:** Never replace a damaged power cable yourself. Power cables must only be replaced by an authorised service technician or a similarly qualified individual. Carefully switch off the circuit breaker in the fuse box if the appliance appears faulty, and contact our friendly after sales support team for further instructions.
- **WARNING:** In order to avoid a fire, this appliance must be regularly cleaned to avoid any potential fat or oil build-up.
- **WARNING:** Do not spray aerosols in the vicinity of this appliance while it is in operation.
- Do not use harsh or abrasive cleaners or sharp metal scrapers to clean the cooktop surface, as these tools may scratch the surface which can result in tarnishing the cooktop finish, or the glass (if relevant) shattering.
- **WARNING:** Do not use steam cleaners.
- If the hob surface is made of toughened ceramic glass: if the surface cracks, switch off the appliance to avoid the possibility of electric shock or further damage, and contact our after sales support team for guidance.
- Ensure that this product is disposed of correctly, to prevent any possible damage to the environment and to human health which might otherwise be caused if the appliance were to be disposed of incorrectly.
- This product may not be treated as normal household waste. It should be taken to a collection point for the recycling of electrical and electronic goods.
- As this appliance requires a specialist waste disposal, for further information regarding the treatment, recovery and recycling of this product please contact your local council, your household waste disposal service or the store of purchase.
- To disassemble and remove the appliance, perform the installation instructions in reverse order. Always perform disassembly with two people to avoid risk of injuries. Installation and disassembly must always be carried out by either an authorised service technician, or a similarly qualified person.
- Materials used for packaging the appliance include those that are environmentally friendly and are 100% recyclable. Environmentally materials have been marked and can be identified with the appropriate symbol.
- Always wear appropriate clothing when cooking, such as non-flammable clothes that cover torso, legs and feet.
- This appliance is labeled in compliance with the European directive 2012/19/EC for Waste Electrical and Electronic Equipment (WEEE). By ensuring that this appliance is disposed of correctly, you will help to prevent any possible damage to our environment and to human health, which might otherwise be caused if it were disposed of in the wrong way.
- The symbol on the product indicates that it may not be treated as normal household waste, instead it should be taken to a collection point for the recycling of electrical and electronic goods.
- This appliance requires specialist waste disposal. For further information regarding the treatment, recovery and recycling of this product please contact your local council, your household waste disposal service, or the shop where you purchased the appliance.
- For further questions please contact our support team at 1300 11 4357 or visit support.residentiagroup.com.au

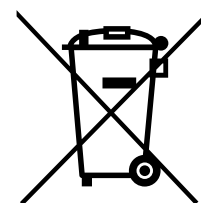

Installation Instructions

Important Safety Instructions

- Make sure to check the condition of the appliance after unpacking it. Do not continue with installation if it has been damaged during transport.
- Safe operation of this appliance can only be guaranteed if it has been professionally assembled and installed in accordance with these instructions by a qualified technician.
- The individual who assembled and installed the appliance is liable for damages or faults resulting from an incorrect assembly or installation.
- Installation and maintenance must be carried out by an authorised service agent or similarly qualified technician.
- Ensure power to the appliance has been shut off before carrying out any installation or maintenance.
- It is vital that the appliance is properly earthed before completing the installation process.
- This appliance must be installed in compliance with: *AS/NZS 5601.1 Gas Installations Part 1: General Installations*, and *AS/NZS 5601.2 Gas Installations Part 2: LP Gas installations in caravans and boats for non-propulsive purposes*, or the relevant installation code for gas appliances in your country.
- This appliance must be installed in compliance with: The local gas fitting regulations, any municipal building codes, electrical wiring regulations or any other relevant statutory regulations.
- This appliance must be installed in compliance with: The following set of installation instructions included in this user manual.
- Ensure that the information on the cooktop's rating label is compatible with your power supply. Do not use any multi-plug adapters or extension cables, and only connect the mains plug at the end of the installation.
- A certificate of compliance **MUST** be given to the customer after the application is successfully installed.
- **CAUTION:** Cooktops supplied have been set up for natural gas, also known as 'NG'. If you wish to use 'LPG', the injectors must be changed using the conversion kit supplied. See the 'LPG Conversion' section on page 10.
- **IMPORTANT:** Your appliance must always be installed by an authorised technician or similarly qualified person. If you wish to arrange an authorised technician please contact our friendly support team at 1300 11 4357 or by visiting the portal at support.residentiagroup.com.au.

Preparing the Cut-Out

Cut-Out Dimensions for 60cm, 70cm & 90cm Cooktops:

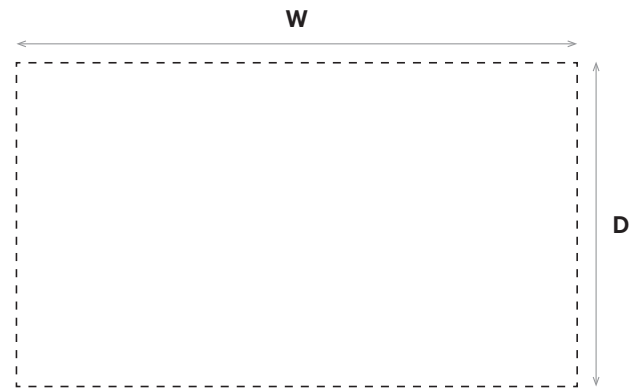

Model	Width (W)	Depth (D)
OCG604WX	560mm	490mm
OCG705WX	560mm	490mm
OCG905WX	730mm	490mm
OCGG604WB	560mm	490mm
OCGG905WB	730mm	490mm

- The bench cut-out should be made as per the relevant cutout dimensions shown above. It is most critical that the cut-out chosen corresponds to your cooktop model.
- **IMPORTANT:** Ensure that the appliance is installed in accordance with *AS/NZS 5601.1*, or *AS/NZS 5601.2* with regard to clearances to combustible surfaces and materials, and clearances to rangehoods and exhaust fans. This is necessary to avoid possible damage to the cabinets during oven usage over time.
- To ensure clearances to combustible surfaces observe the minimum distance requirements, follow the relevant information shown in the above table, corresponding to your model.

Installation Instructions

Installation Procedure

- A barrier must be installed to prevent accidental contact with the cooktop base, where the base of the cooktop is accessible from below (i.e. Inside a cupboard, etc.).
- A minimum clearance of 25mm must be maintained between the base and the barrier. This barrier may be made of any non-combustible, rigid material.
- Barrier protection is not necessary if the product is installed above an underbench oven or similar appliance and/or if the cupboard construction is such that the underside of the cooktop is not accessible.
- Ensure that there is an earthed power outlet within 900mm of the rear right hand side of the cooktop when installed. This should be accessible at all times.
- A self-adhesive foam tape has been provided to act as a sealing agent and is to be placed around the edge of the hob underside. Ensure there are no gaps when applying the tape.
- Take care to ensure that the seals meet without overlapping. The thickness of this foam tape is 3mm and the width is 10mm. Avoid leaving any visible excess seal after installation is complete.
- **WARNING:** Do not use any kind of silicon sealant to seal the appliance against the benchtop. This will make it difficult to remove the appliance, which must be accessible for the service agent to perform any necessary repairs in the future.
- Clamps and screws are supplied with your cooktop. Fit the pull down clamps supplied to ensure that the cooktop cannot move after installation. Refer to the diagram shown below, and the relevant instructions.
- **WARNING:** Failure to fix the cooktop to the bench could result in loosening of the gas connection through movement of the cooktop and a gas leak may result.
- If your benchtop is less than 35mm in thickness, it may be necessary to fit a spacer between the benchtop and each clamp to ensure they can be tightened sufficiently.

Fitting the Clamps

Before resuming, ensure you have applied the sealing strips. Always wear appropriate protection while carrying out installation, such as gloves and fully enclosed shoes.

To continue with the installation, ensure you have on hand: a *screwdriver*, a *soft towel*, the *supplied clamps and screws*.

1. Ensure that any loose burner components and trivets have been removed from the cooktop.
2. Place the hob upside down on a soft surface to protect both the hob and your work surface from damage.
3. Place the bracket (B) over the holes that match the size of the screws. There are one set of screw holes in each corner of the hob. Slightly tighten a screw (C) through the bracket (B) so that the bracket is attached to the hob whilst still allowing you to adjust it's position.
4. In a team of two, carefully turn the hob back over and then gently lower it into the aperture hole that you have cut-out in your benchtop.
5. On the underside of the hob, adjust the brackets into a position that is suitable for your benchtop.
6. Then fully tighten the screws (C) to secure the cooktop into its final position.

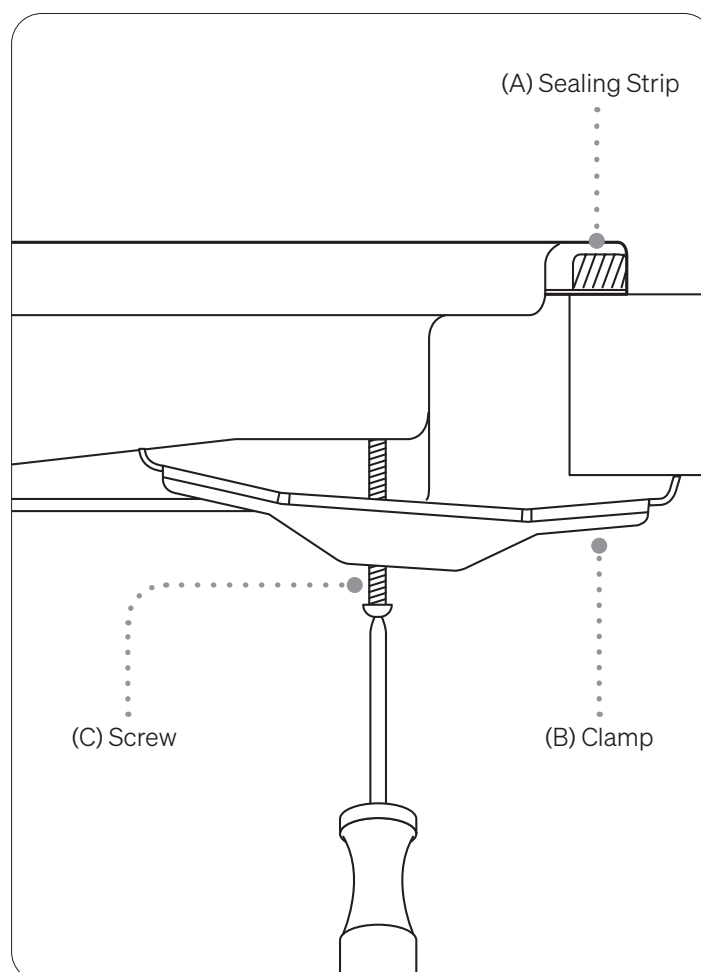

Installation Instructions

Elbow Positioning

Assembly of elbow to manifold at rear of unit requires two spanners to secure locking nut and ensure leak free connection. For this reason the elbow is best secured onto cooktop manifold before installing unit into benchtop.

- It is possible to reposition the elbow if required by loosening the locking nut and elbow using two spanners. Re-tighten the entire assembly after the elbow has been repositioned. When fitting elbow to appliance, ensure that the sealing washer is fitted.
- Begin by loosening the elbow, then adjust the elbow interface to the necessary direction as required. Keep the hexagonal head of the elbow motionless with a wrench.
- Use a $9\pm 1\text{N.m}$ torque wrench to tighten the black bolt of the gas inlet pipe assembly. Ensure that the torque of the wrench is within the required range to prevent elbow breakage or damage caused by excessive force.
- After the installation is tightened, check whether the parts are in good condition and test the air tightness to ensure the tightness of the installation. The installer is responsible for the results of the process.

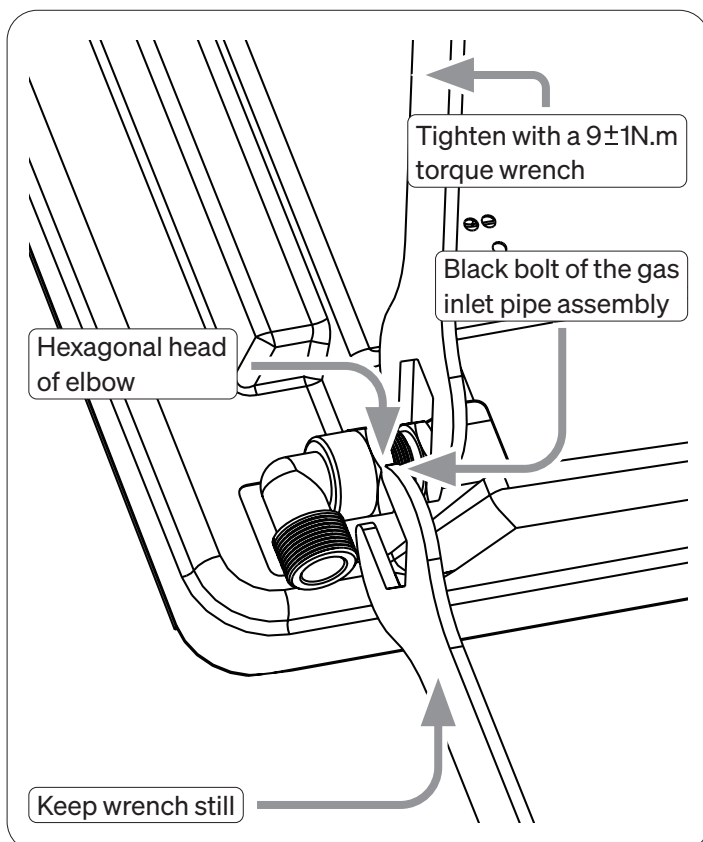

Operating with Natural Gas

- Your appliance is designed to run both LPG and natural gas. Conversion for use of LPG and substitute natural gases must only be undertaken by a qualified person. Despite your appliance having been set-up for use with natural gas, it can be converted for use with LPG. To learn more please refer to the LPG Conversion section on page 10.

Supply Pipe Sizing

- The total hourly gas consumption for the appliance is shown on the rating label. The required supply pressure (i.e. at inlet to appliance regulator) for each gas type is also shown on the rating label, and is shown in the Technical Specifications chapter found on page 13 through to 19.

Example of MJ/h Values

Auxiliary Output:	4.0MJ/h
Semi-Rapid Output:	6.9MJ/h
Rapid Output:	11.5MJ/h
Wok Output:	19.7MJ/h

- Use this information in conjunction with the length of run, number of elbows, tees and bends, the available service pressure and the supply requirements of other installed appliances to determine a suitable pipe size.
- For assistance in this matter refer to the appropriate section of AS/NZS 5601.1 or AS/NZS 5601.2.
- An AGA certified class B or D flexible connection may be used to connect the cooktop in accordance with AS/NZS 5601.1, in particular section 5.9 and clause 6.10.1.8, or AS/NZS 5601.2, in particular section 2.11.
- Where a hose assembly is used and the cooktop is in the installed position, the hose assembly shall be suitable for connection to a fixed consumer piping outlet located at a point of 800–850mm above the floor and in the region outside the width of the appliance to a distance of 250mm. The point of connection to consumer piping must be accessible after the appliance has been installed.

Installation Instructions

Assembling the Gas Regulator

An appliance regulator is provided. The regulator must be positioned so that the pressure test nipple is accessible when the appliance is installed.

- Connect the gas supply to the ½" B.S.P. internal thread inlet of the regulator. See the cut-out diagrams on page 06 for the ideal connection point position.
- The assembly of the regulator to the cooktop manifold is achieved by using both the supplied elbow union and sealing washer, for a visual aid please refer to the diagram below.
- The ½" parallel thread connects to the manifold, and the sealing washer is placed between the manifold end and the flat face on the elbow.
- The ½" tapered thread connects to the outlet of the regulator, and is sealed on the thread either by using an approved thread sealing tape, or an approved thread sealing compound.
- The inlet of the regulator is a ½" parallel thread and is connected to consumer piping or hose assembly.
- Regulators are supplied pre-adjusted and configured by the component maker for use with Natural Gas. The appliance installer is not required to make an adjustment to obtain the correct outlet pressure setting.
- An arrow on the base of the regulator indicates the direction of gas flow when the inlet and outlet of the regulator is orientated correctly. When the regulator has been fitted check for leaks from the connections with soapy water.

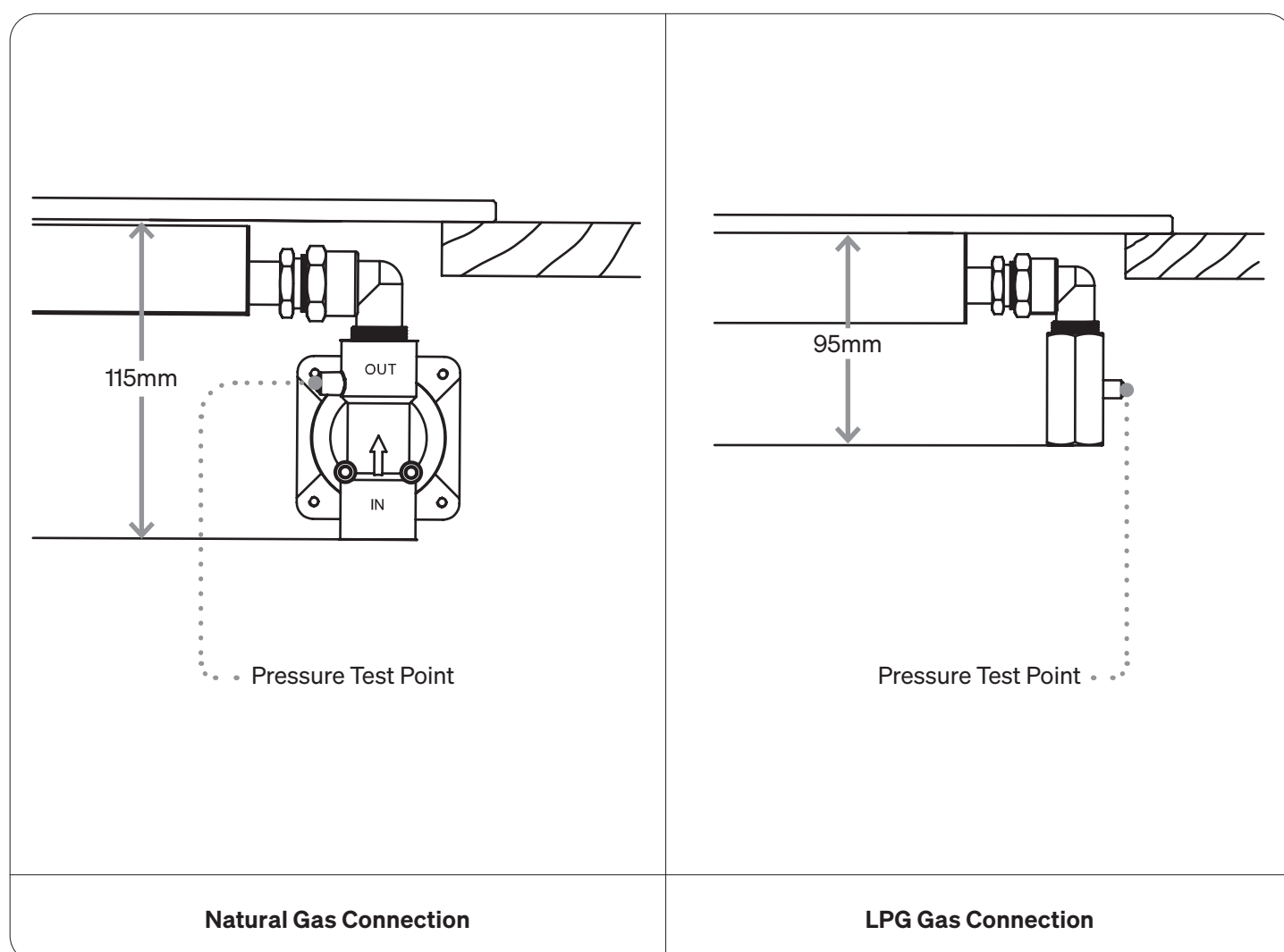

Installation Instructions

Testing the Gas Supply

Check the manometer zero point is correct. Then connect the manometer to the cooktop pressure point. This is located on the regulator.

Turn on the gas supply and electricity and try to ignite the gas. Note that it will take additional time to light the gas for the first time as air needs to be purged from the pipes.

Following this, with the appliance operating, carefully check the outlet pressure:

- First with all burners of operating at maximum, followed by operating. the smallest burner at minimum.
- Under these conditions the outlet pressure should not vary from the nominal outlet pressure of 1.00kPa by more than $\pm 0.20\text{kPa}$.

If the regulator appears to not be performing satisfactorily, then check the following points:

- If the outlet pressure is consistently too low then the inlet pressure may be too low and adjustment of an upstream regulator may be needed, or an upstream regulator or valve with insufficient flow capacity may be present in the gas supply line.
- If this is suspected then it may be necessary to repeat the checks whilst measuring both the inlet and outlet pressure to determine if the inlet pressure is in the range 1.13 – 5kPa.
- Check that the regulator has been fitted to the gas supply line in the correct orientation, the arrow on the base of the body indicates the direction of gas flow.

Once these checks have been completed, if the regulator still fails to perform in a satisfactory manner it should be replaced.

Nominal Test Point Pressures:	
Natural Gas = 1.00kPa	LPG = 2.75kPa
<p>-----</p> <p>For further technical information regarding your cooktop, please see the chapter 'Technical Specifications' found between pages 13 and 19, and your cooktop's rating label.</p> <p>-----</p>	

LPG Conversion

Your cooktop has been set up for natural gas usage, however a conversion kit is included with the product for universal LPG usage. The conversion kit contains the appropriate injectors, a brass test point and an LPG sticker.

Please follow the procedure below if a conversion to suit UNIVERSAL LPG is required:

- Remove the hotplate trivets, burner caps and burner crowns to access the hotplate injectors. Replace the factory fitted injectors with the appropriate injectors, as supplied. Refer to injector orifice table for injector sizes. The injector size is stamped on the side of the injector.
- Connect the brass test point adapter (pictured previously on page 08) using approved gas thread tape or compound to the elbow fitting.
- Turn on the gas supply and at each new connection check for leaks using soapy water. Each hotplate valve should be turned on, one at a time, and the injector hole blanked off for several seconds.
- With the appliance operating, check the outlet pressure both when all burners of the appliance are operating at maximum, and when the smallest burner of the appliance is operating at minimum. Under these conditions the outlet pressure should not vary from the nominal outlet pressure of 2.60kPa by more than $\pm 0.52\text{kPa}$.
- If the regulator appears to not be performing satisfactorily then check the following points:
 - If the outlet pressure is consistently too low then the inlet pressure may be too low and adjustment of an upstream regulator may be needed, or an upstream regulator or valve with insufficient flow capacity may be present in the gas supply line.
 - If this is suspected then it may be necessary to repeat the checks whilst measuring both the inlet and outlet pressure to determine if the inlet pressure is in the range 2.75–7.00kPa.
- One by one, turn the knobs to minimum and screw in the bypass screw (accessible when the knob is removed) until a small stable flame results; a length of 3–4mm. Turn the knob to maximum and then back to minimum to ensure that the correct minimum flame is maintained.
- Attach the LPG sticker to the cooker, near the gas supply inlet. Cover the natural gas label that is factory fitted.
- The process of LPG conversion is then complete.

Installation Instructions

Electrical Connection

Your Omega cooktop has been designed to operate on a power supply voltage of 220-240V, single phase, and has been fitted with a 10 amp, 3 pin plug.

Before making the electrical connection, ensure that the following points are observed:

- Confirm that your electrical system is able to withstand the load of the appliance, for further information please see your cooktop's rating label.
- Ensure that the power supply system's earth connection is in good condition and that it accords with the relevant regulations in force.
- Make sure that the general purpose outlet is easily accessible once the appliance has been installed.

It is critical that the power supply lead must be positioned so that it does not exceed 50°C above room temperature.

An ideal set-up is shown in the diagram below.

The electrical cable is guided by clips fixed to the back-side of the cabinet, this helps to avoid any potential contact with appliances that may be underneath the cooktop.

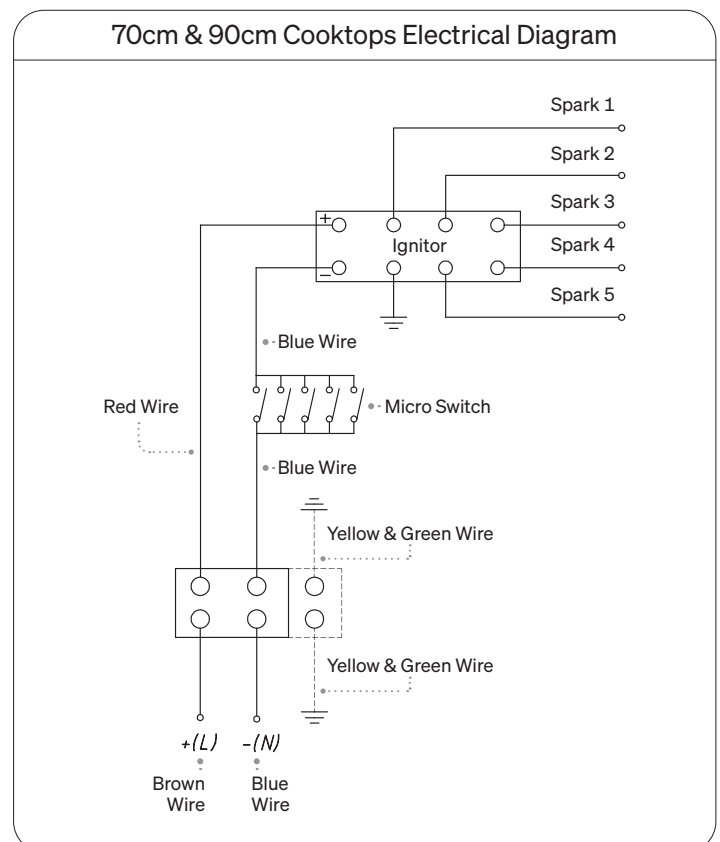
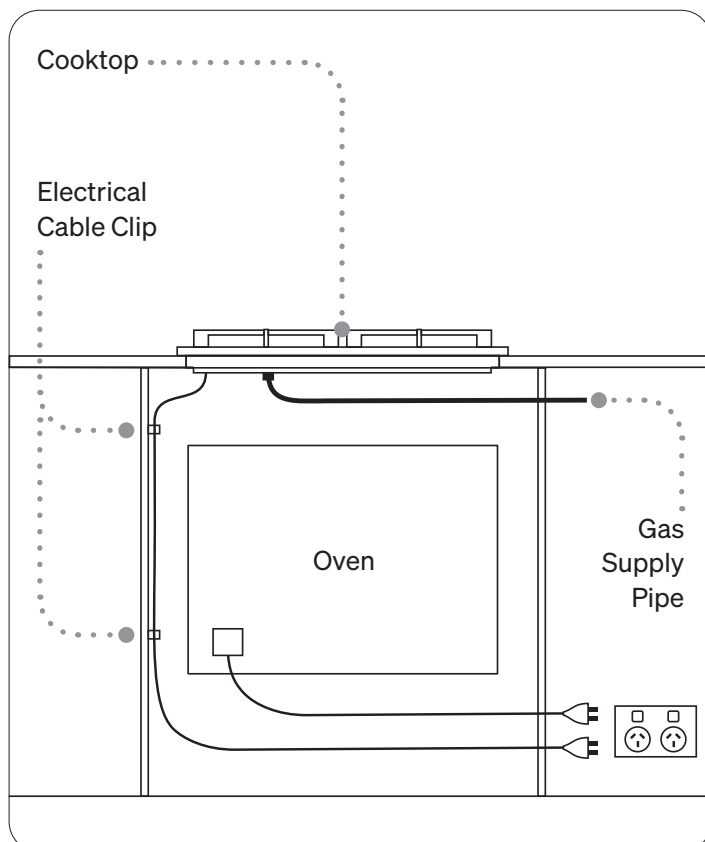
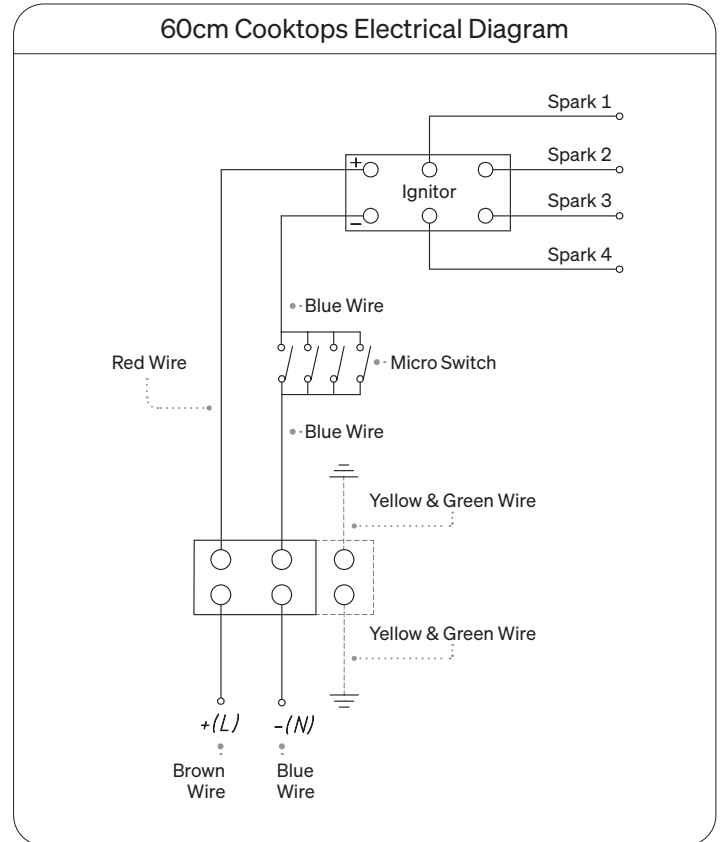

Installation Instructions

Testing Appliance Operation

After installation, test the appliance and ensure that it operates correctly before handing it over to the customer. The following procedure is recommended:

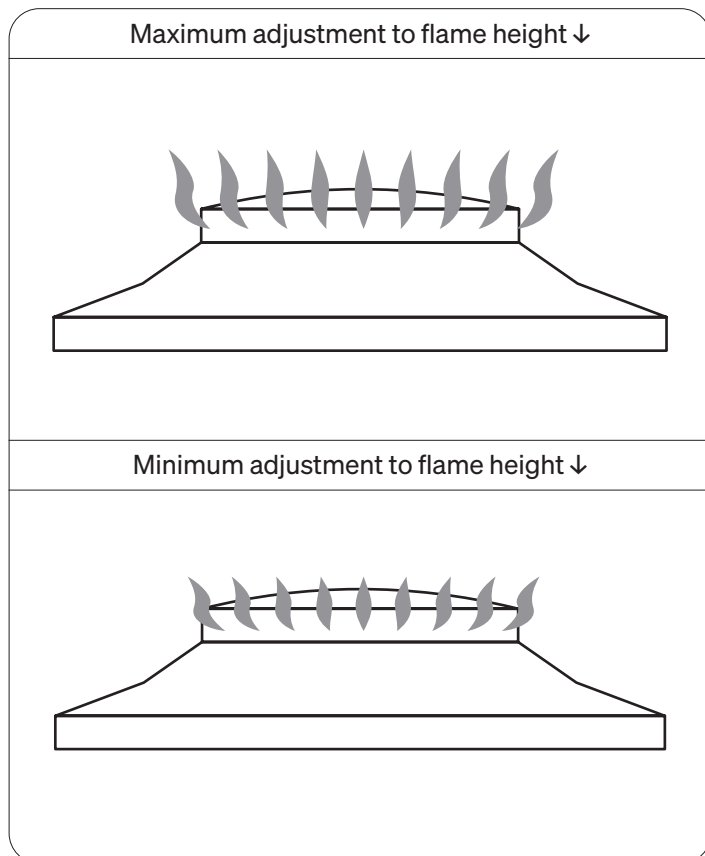

- Begin by turning on the gas and electricity supply, then attempt to ignite all of the burners, both separately and in combination. Note that additional time may need to be allowed for the initial lighting, as air has to be purged from the pipes.
- Observe the flame appearance on each burner, shown in the diagram above. If it is much larger or much smaller than expected, the injector size and supply pressure require checking. Where a flame is unsatisfactory, refer to the troubleshooting guide on page 25 to correct the fault. If the troubleshooting guide does not solve the problem, please call our friendly After Sales Support Team.
- When all the foregoing is satisfactory, check the turn down (minimum or low) setting on each burner, as this may need adjustment. Valves have a bypass controlling screw, which may be accessed by removing the knob, as shown in the diagram to the right. This screw will be located on a particular area of the valve. Normally, this will have been correctly set at the factory for use on natural gas (NG) and should not require adjustment.

- **IMPORTANT:** If the appliance has been converted to LPG, then the bypass screw will HAVE to be screwed in until a small, stable flame results.
- **IMPORTANT:** ensure the supply pressure has been checked PRIOR to any adjustment.

If the cooktop's flame cannot be adjusted to perform safely inform the customer of the problem and affix an appropriate warning notice to the appliance. If the fault appears to be dangerous the appliance should be disconnected. If a minor fault exists, the customer may wish to use the appliance while awaiting service.

If a fault cannot be fixed, please call the our friendly After Sales Support Team at 1300 11 4357.

The customer should be advised that, in the event of a fault, the local service organisation or the retailer from whom the appliance was purchased should be contacted.

When satisfied that the unit is operating correctly, turn off and instruct the customer on correct operation as outlined in this booklet. Ask the customer to operate the controls to ensure that the correct procedure is understood.

CAUTION: Servicing must only be carried out by an authorised service technician.

Injector sizes required for various gas types are shown in the Technical Specifications chapter found on page 13 through to 19, and may depend on your model. The appliance test point pressure for each gas type is also shown.

For model identification after installation, an additional rating label sticker has been provided. This sticker is to be stuck onto adjacent cabinetry.

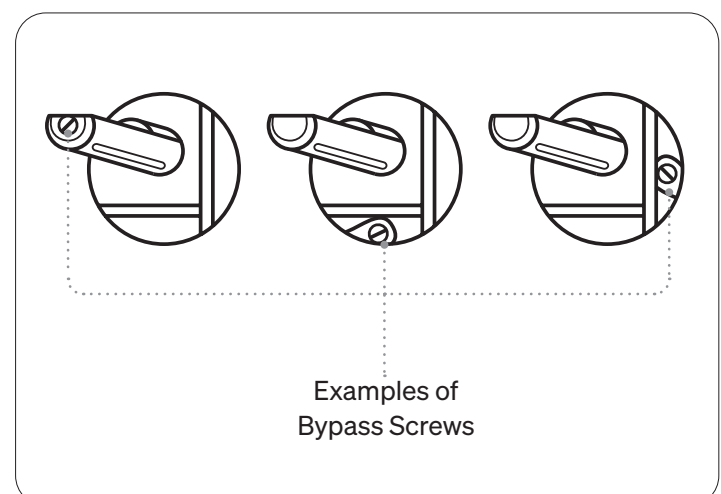

Technical Specifications

Specifications Chart: OCG604WX

Model Number	OCG604WX
Cooktop Finish	Stainless Steel
Trivet Material	SafeSlide Cast Iron
Rated Voltage	220–240V~
Rated Frequency	50–60Hz
Rated Power	5W
Burner Output: Auxiliary (×1)	4.0 MJ/h
Burner Output: Semi-Rapid (×2)	6.9 MJ/h
Burner Output: Wok (×1)	14.5 MJ/h
Total Burner Output	32.3 MJ/h
Gas Compatibility	Natural Gas & LPG
Power Connection	10 Amp, Plug & Play
Product Weight (Net / Gross)	14.5 kg / 16.5 kg
Dimensions (W × D × H)	580 × 510 × 64 mm
Cut-Out Dimensions (W × D)	560 × 490 mm

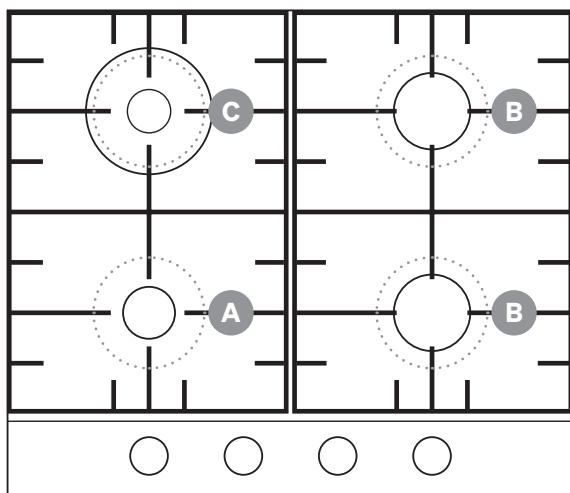

Key

- A. Auxiliary Burner
- B. Semi-Rapid Burner
- C. Wok Burner

Technical Specifications

Specifications Chart: OCG705WX

Model Number	OCG705WX
Cooktop Finish	Stainless Steel
Trivet Material	SafeSlide Cast Iron
Rated Voltage	220–240V~
Rated Frequency	50–60Hz
Rated Power	5W
Burner Output: Auxiliary (×1)	4.0 MJ/h
Burner Output: Semi-Rapid (×2)	6.9 MJ/h
Burner Output: Rapid (×1)	11.5 MJ/h
Burner Output: Wok (×1)	20.0 MJ/h
Total Burner Output	49.3 MJ/h
Gas Compatibility	Natural Gas & LPG
Power Connection	10 Amp, Plug & Play
Product Weight (Net / Gross)	15.0 kg / 17.0 kg
Dimensions (W × D × H)	680 × 510 × 64 mm
Cut-Out Dimensions (W × D)	560 × 490 mm

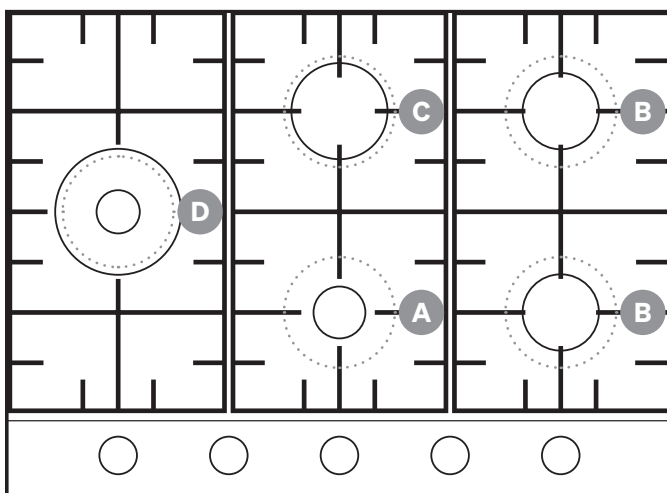

Key

- A. Auxiliary Burner
- B. Semi-Rapid Burner
- C. Rapid Burner
- D. Wok Burner

Technical Specifications

Specifications Chart: OCG905WX

Model Number	OCG905WX
Cooktop Finish	Stainless Steel
Trivet Material	SafeSlide Cast Iron
Rated Voltage	220–240V~
Rated Frequency	50–60Hz
Rated Power	5W
Burner Output: Auxiliary (×1)	4.0 MJ/h
Burner Output: Semi-Rapid (×2)	6.9 MJ/h
Burner Output: Rapid (×1)	11.5 MJ/h
Burner Output: Wok (×1)	19.7 MJ/h
Total Burner Output	49.0 MJ/h
Gas Compatibility	Natural Gas & LPG
Power Connection	10 Amp, Plug & Play
Product Weight (Net / Gross)	21.0 kg / 23.5 kg
Dimensions (W × D × H)	860 × 510 × 64 mm
Cut-Out Dimensions (W × D)	730 × 490 mm

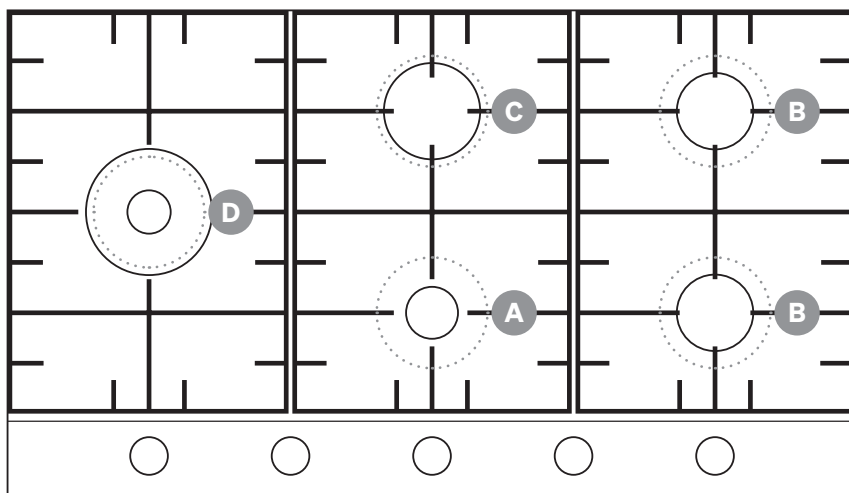

Key

- A. Auxiliary Burner
- B. Semi-Rapid Burner
- C. Rapid Burner
- D. Wok Burner

Technical Specifications

Specifications Chart: OCGG604WB

Model Number	OCGG604WB
Cooktop Finish	Gas on Glass
Trivet Material	Cast Iron and Brass
Rated Voltage	220–240V~
Rated Frequency	50–60Hz
Rated Power	5W
Burner Output: Auxiliary (×1)	4.0MJ/h
Burner Output: Semi-Rapid (×2)	6.9 MJ/h
Burner Output: Wok (×1)	14.5 MJ/h
Total Burner Output	32.3 MJ/h
Gas Compatibility	Natural Gas & LPG
Power Connection	10 Amp, Plug & Play
Product Weight (Net / Gross)	14.5kg / 16.5kg
Dimensions (W × D × H)	580 × 510 × 62 mm
Cut-Out Dimensions (W × D)	560 × 490 mm

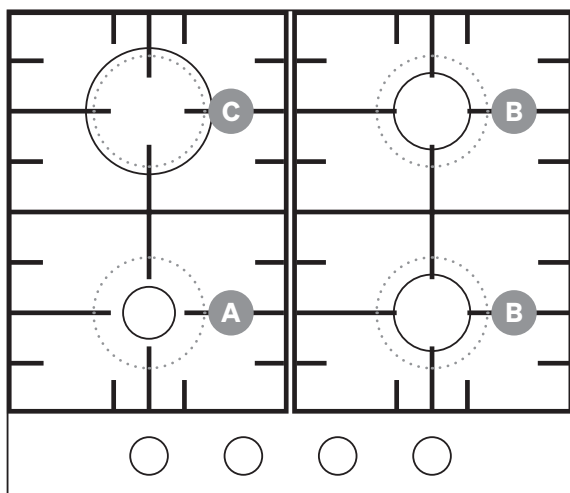

Key

- A. Auxiliary Burner
- B. Semi-Rapid Burner
- C. Wok Burner

Technical Specifications

Specifications Chart: OCGG905WB

Model Number	OCGG905WB
Cooktop Finish	Gas on Glass
Trivet Material	Cast Iron and Brass
Rated Voltage	220–240V~
Rated Frequency	50–60Hz
Rated Power	5W
Burner Output: Auxiliary (×1)	4.0 MJ/h
Burner Output: Semi-Rapid (×2)	6.9 MJ/h
Burner Output: Rapid (×1)	11.5 MJ/h
Burner Output: Wok (×1)	19.7 MJ/h
Total Burner Output	49.0 MJ/h
Gas Compatibility	Natural Gas & LPG
Power Connection	10 Amp, Plug & Play
Product Weight (Net / Gross)	21.0 kg / 23.5 kg
Dimensions (W × D × H)	860 × 510 × 62 mm
Cut-Out Dimensions (W × D)	730 × 490 mm

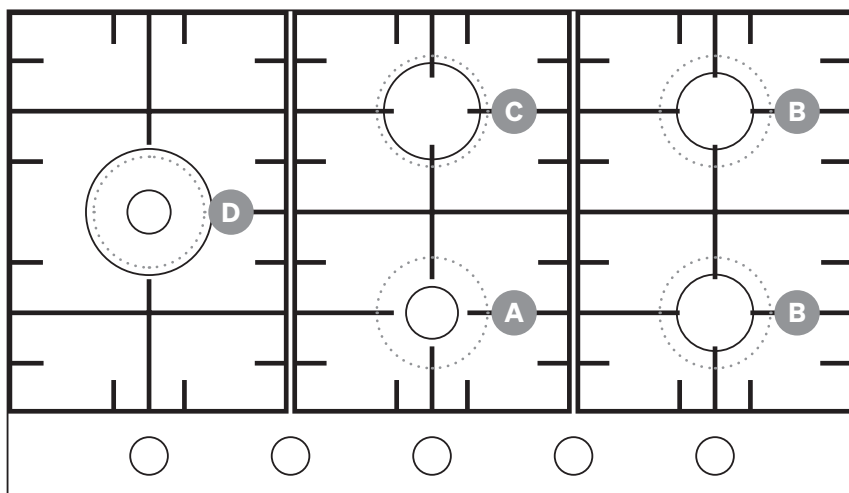

Key

- A. Auxiliary Burner
- B. Semi-Rapid Burner
- C. Rapid Burner
- D. Wok Burner

Cooktop Overview

Key

A. Auxiliary Burner

B. Semi-Rapid Burner

C. Rapid Burner

D. Wok Burner

E. Controls

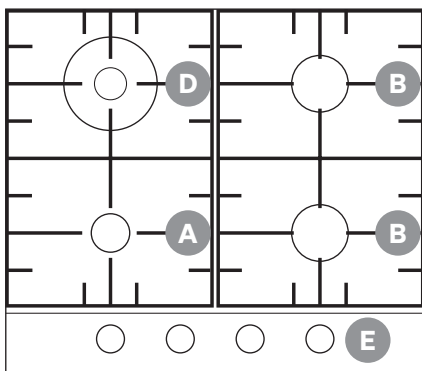

↑ OCG604WX

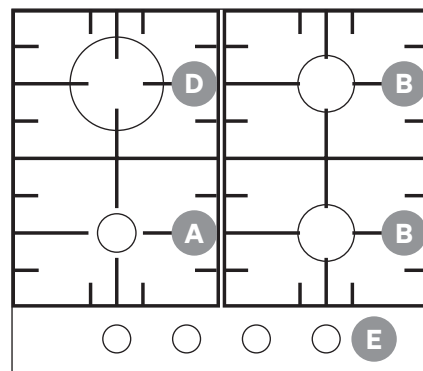

↑ OCGG604WB

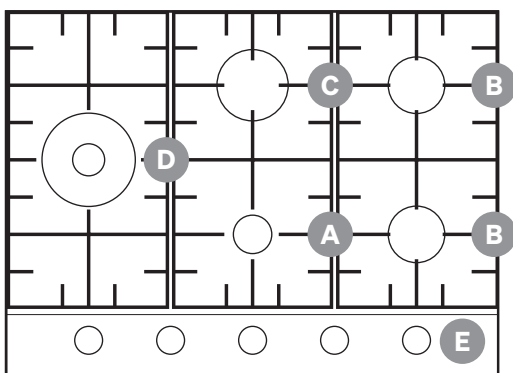

↑ OCG705WX

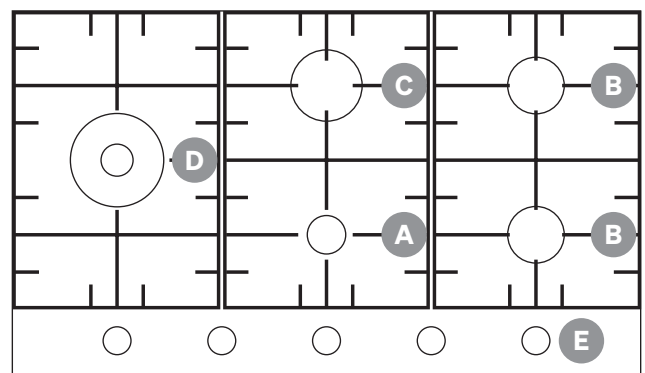

↑ OCGG905WB

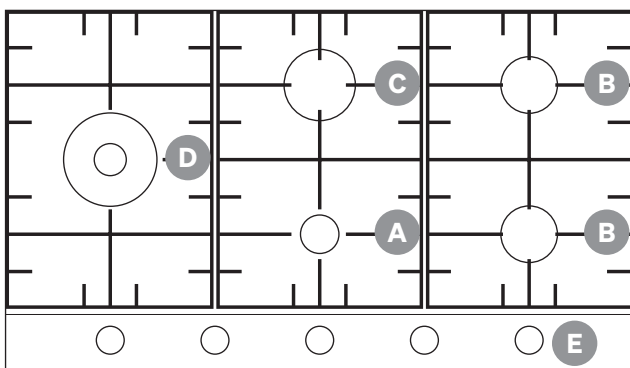

↑ OCG905WX

Cooktop Overview

Burner Key

A. Burner Lid

B. Burner Skirt

C. Ignition Spark Plug

D. Injector Jet

E. Flame Sensor

F. Flame Ports

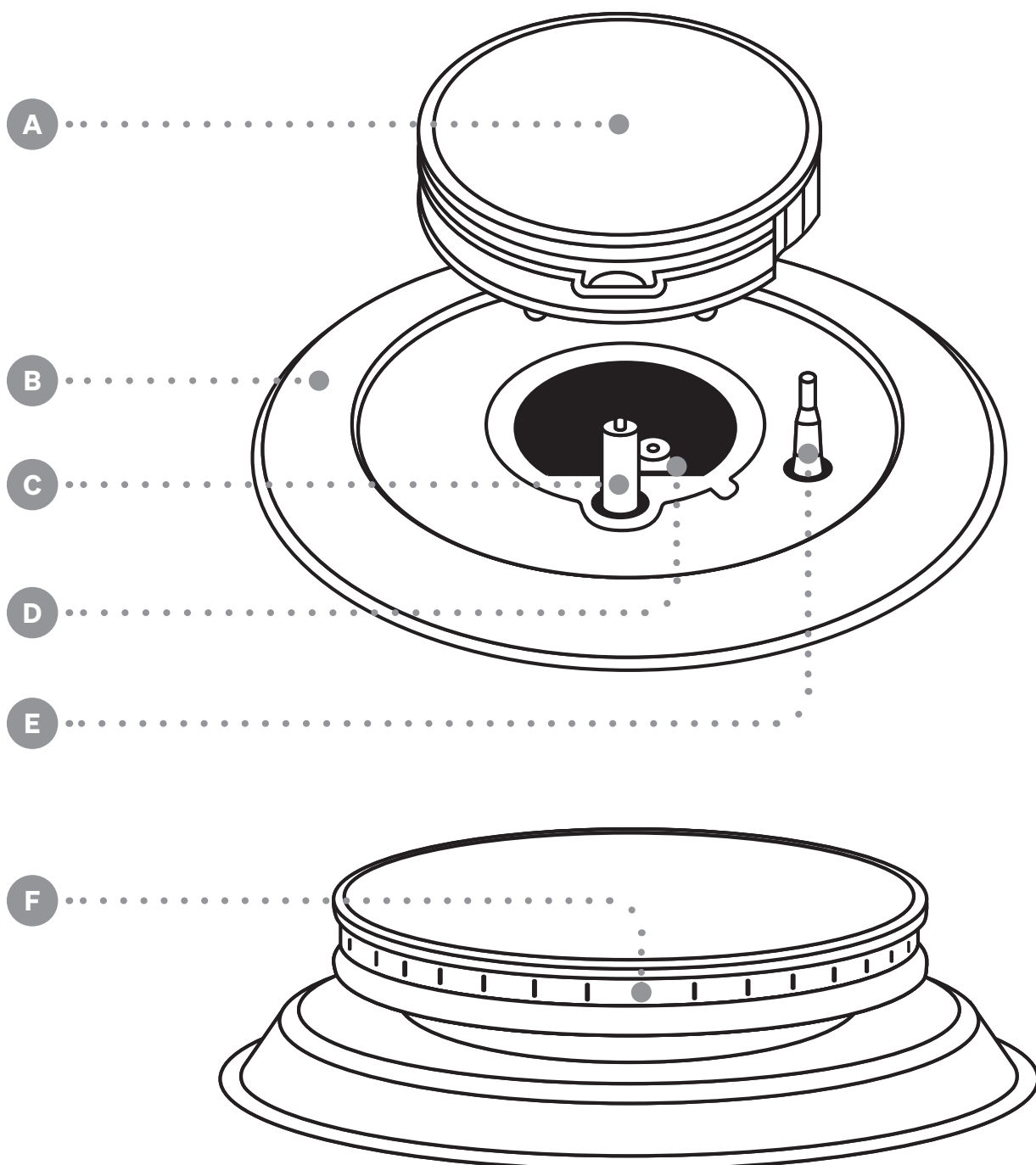

Operating Your Cooktop

Cooking With Your Gas Cooktop

Place a suitable pan on the burner you wish to use, following page 23's cookware guide.

Make sure that the bottom of the pan and the surface of the cooktop are clean and dry, and that there are no cracks or oil build-up present.

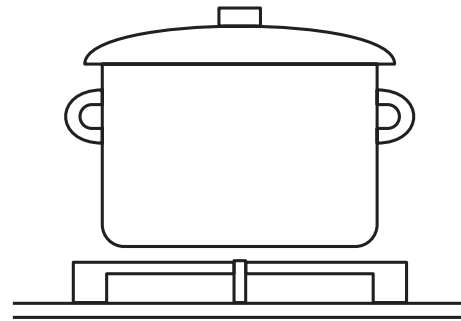

To begin cooking, take note of the burner you wish to use and find the corresponding control knob. Press down for approximately 5 seconds, and the flames will then emit.

Note that the heat level must be set within the 'LOW' to 'MAX' settings.

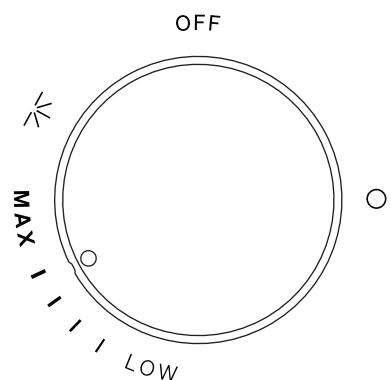

When you have finished cooking, turn the control knob clockwise towards the 'OFF' position, and once the flames from the burner have dispersed, simply let go.

Note that the burner that was previously used will be hot for some time, so caution should be always be exercised even after cooking is over.

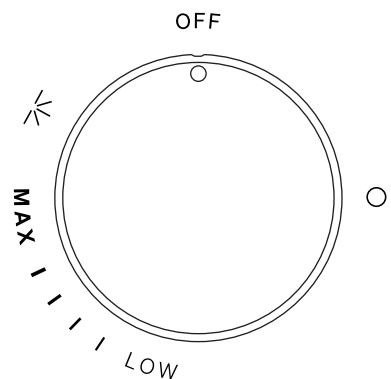

Your cooktop has been fitted with an electric ignition. When the cooktop has been connected and the power is on, pressing any knob will release sparks to all burners, instantly.

However, in the absence of electrical power, for example a local power outage, you can carry out the ignition directly to the burner with a hand-held ignition source, such as a lighter.

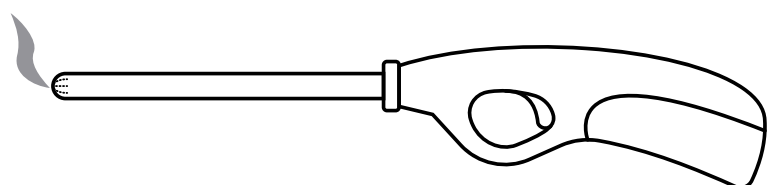

Operating Your Cooktop

Choice of Burner

Below is a guide to using your cooktop's burners:

- Auxiliary: For special low heat and slow cooking.
Cookware Size: Ø120mm – Ø160mm.
- Semi-Rapid: For normal cooking and simmering.
Cookware Size: Ø160mm – Ø180mm.
- Rapid Burner: For fast heating with medium pots.
Cookware Size: Ø200mm – Ø240mm.
- Wok Burner: For quick heating with large cookware.
Cookware Size Ø200mm – Ø240mm.

For best results, centre your cookware on the desired burner and adjust the flame level so that it does not extend past the cookware's edge. Below are some examples of pot placement.

Choice of Cookware

Many common pots and pans, such as those made from aluminium, ceramic, cast-iron and stainless steel may be used on your new gas cooktop.

Ensure that the pots or pans are steady and have flat bases to avoid dangerous spill-over of hot liquids and wasted energy.

Do not use cookware with jagged edges, coarse or uneven surfaces, chipped bottoms or a curved base.

Make sure that the base of your cookware is smooth, sits flat against the trivets, and is the same size as the chosen burner, and always centre your pan on the cooking zone.

For best practice, gently lift cookware off the trivets—avoid sliding them, as the bottom of your cookware, and the trivets' surface may become scratched.

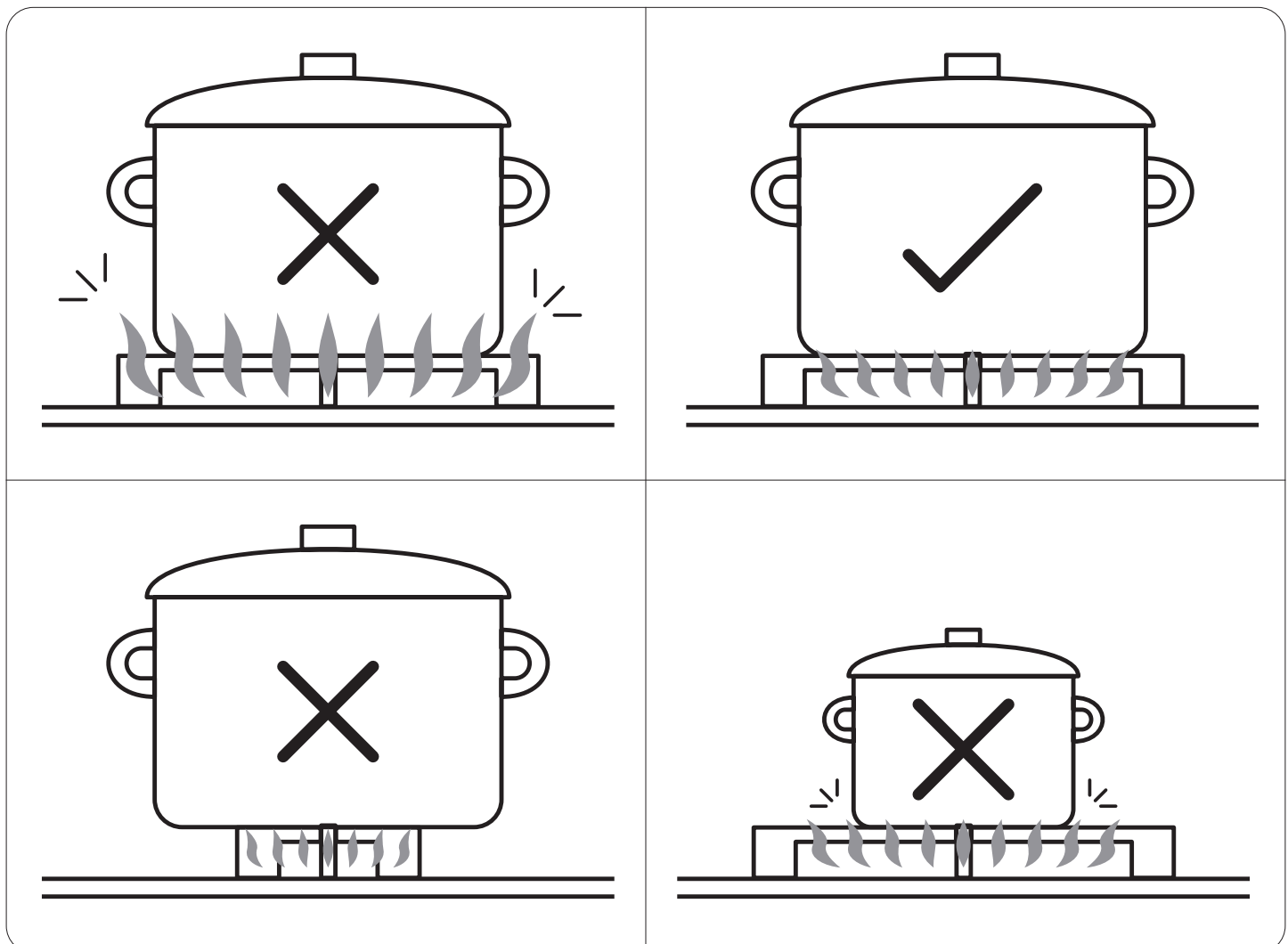

Care & Maintenance

Before Cleaning

- Read this user manual carefully, taking special note of the 'Safety Information' chapter in particular.
- Prior to cleaning ensure that the cooktop is both turned off, and has been given the chance to properly cool down.
- NEVER place trivets or burners in the dishwasher, instead opt for hand-washing followed by immediate drying.

SafeSlide Trivets & Cooktop Burners

- Trivets and burners can be lifted up and removed for cleaning. See page 21 for a guide to burner assembly.
- Persistent stains may require some rubbing with a nylon scourer or creamed powder cleansers. Household enamel cleaners are available, follow the manufacturer's instructions in their use. Harsh abrasive cleaners, powder cleaners, steel wool or wax polishes should not be used.
- Always thoroughly dry burners after cleaning or spillage. When cleaning them, ensure that all the flame ports are free of any blockage. If necessary, you can use a toothpick or brush to clear ports.
- The outer surface of the burner caps have a polished finish; extra care needs to be taken to avoid scratching during cleaning. In instances of heavy soiling, it may be necessary to apply a non-abrasive cleaning compound and rub with a cloth until the soiling is removed.

Ignition Spark Plug & Flame Sensor

- Gently clean both with a damp cloth to avoid lighting difficulties. Ensure that they are dry before use.

Cooktop Surface

- **CAUTION:** In some cases it is helpful to clean up and remove spillages immediately, while the hob is still hot. This is especially the case for sugary foods such as jam, or melted plastics and foil; all of which can damage the hob if left. If cleaning while the cooktop is hot, exercise caution and wear protective clothing.

Stainless Steel

- Stainless steel surface may discolour over time. This is normal due to the high cooking temperatures. Each time the cooktop is used, it should be cleaned with a product that is safe and suitable for stainless steel, such as a soft cloth or sponge with detergent and warm water.

Gas on Glass

- The cooktop's surface material is made of toughened glass, manufactured to the highest possible standards for both safety and reliability. However, it must always be remembered that as it is glass, it may break, so always take care of it. To clean the glass surface, use a soft cloth or sponge with detergent and warm water.
- **WARNING:** If the surface of the cooktop becomes cracked, switch off the appliance immediately to avoid the possibility of electric shock. A cracked cooktop is considered a serious fault, and if it occurs you should contact our After Sales Support Team immediately.

Burner Injector Jet

- Ensure the injector remains free of any foreign material. If necessary, use a thin piece of wire to clear the orifice.

For Serious Faults

- Some minor faults can be fixed by referring to the table above, however if an emergency or serious fault occurs, immediately set all controls to their off positions and disconnect the power from the source.
- If a serious fault occurs, DO NOT attempt any repairs yourself, instead wait for a service agent to do so.
- For assistance or to organize an authorised service agent contact our After Sales Support by calling 1300 11 4357, or by emailing support@residentiagroup.com.au.
- Please note that if a service agent is asked to attend whilst the product is under warranty and finds that the problem is not the result of an appliance fault, then you may be liable for the cost of the call out charge.
- The appliance must be accessible for the service agent to perform any necessary repair. If your appliance is installed in such a way that a service agent is concerned that damage will be caused to the appliance or your kitchen, then they will not complete a repair.
- Please refer to the Warranty Information to learn more.

For Minor Faults

Problem	Possible Cause	Solution
One of the burners is not lighting up, even though the sparker appears to be working normally.	The knob may not have been pushed down long enough to deactivate the burner's flame safeguard.	Repeat the lighting procedure, however this time hold the knob down for 5 seconds or longer.
	A gas supply valve may be shut off.	Turn on the appliance's gas supply.
	You may have accidentally turned a different knob that does not correspond to the burner you want.	Carefully ensure that the knob you are turning corresponds to the burner you want to light.
	A port blockage in the burner's ignition area may have occurred, likely due to irregular cleaning.	Ensure that the ports in each of the burner's ignition areas is clean and dry.
	It's possible the ignition spark plug may be wet or dirty.	Gently clean and dry the ignition spark plugs before resuming.
When holding down a control knob, no spark is being emitted.	The cooktop's electricity supply is disconnected or has been turned off. A local power outage can also affect the cooktop's functioning.	Ensure the cooktop is connected to the power, and that the power has been switched on. Check if there is a power outage in your home or area.
	It's possible the ignition spark plug may be wet or dirty.	Gently clean and dry the ignition spark plugs before resuming.
Flames emitted from the burner are uneven, or tending to lift.	The flame ports may be blocked or wet.	Carefully clean and then dry the ports.
	A burner cap may be incorrectly fitted.	Ensure the components are well fitted.
Flames from the burner are not staying lit after the knob has been released.	The knob may not have been pushed down long enough to deactivate the burner's flame safeguard.	Repeat the lighting procedure, however this time hold the knob down for 5 seconds or longer.
	The knob may not have been set between the valid power levels, 1–9.	In order for the burner to stay lit, the knob must be set between levels 1–9.
	There may be dirt or spillage covering the flame safeguard sensor.	Carefully clean and dry the flame safeguard sensor before resuming.
The cookware is not heating up well, and cooking is happening too slowly.	An incompatible piece of cookware may have been used.	Please refer to page 23 for further instructions regarding cookware.
The cooktop surface, surrounding benchtop, or the cooktop control knobs have started overheating.	An incompatible piece of cookware may have been used.	Please refer to page 23 for further instructions regarding cookware.
	The cookware may not be placed on the burner and trivets properly.	Ensure that the cookware is centred correctly on the burner and trivet.

Purchase Details

Attach your receipt to this page

For future reference, please record the following information which can be found on the rating plate and the date of purchase which can be found on your sales invoice.

Store Details

Store Name

Address

Telephone

| Purchase Date

Product Details

Model No.

Serial No.

Warranty Information

WARRANTY TERMS AND CONDITIONS GAS COOKTOPS

This document sets out the terms and conditions of the product warranties for Residentia Group Appliances. It is an important document. Please keep it with your proof of purchase documents in a safe place for future reference should you require service for your Appliance.

1. In this warranty
 - (a) 'acceptable quality' as referred to in clause 10 of this warranty has the same meaning referred to in the ACL;
 - (b) 'ACL' means Trade Practices Amendment (Australian Consumer Law) Act (No.2) 2010;
 - (c) 'Appliance' means any Residentia Group product purchased by you accompanied by this document;
 - (d) 'ASR' means Residentia Group authorised service representative;
 - (e) 'Residentia Group' means Residentia Group Pty Ltd of 165 Barkly Ave, Burnley VIC 3121, ACN 70 600 546 656 in respect of Appliances purchased in Australia;
 - (f) 'major failure' as referred to in clause 10 of this warranty has the same meaning referred to in the ACL and includes a situation when an Appliance cannot be repaired or it is uneconomic for Residentia Group, at its discretion, to repair an Appliance during the Warranty Period;
 - (g) 'Warranty Period' means:
 - (i) where the Appliance is used for personal, domestic or household use (i.e. normal single family use) as set out in the instruction manual, the Appliance is warranted against manufacturing defects for 36 months, following the date of original purchase of the Appliance;
 - (h) 'you' means the purchaser of the Appliance not having purchased the Appliance for re-sale, and 'your' has a corresponding meaning.
2. This warranty only applies to Appliances purchased and used in Australia and is in addition to (and does not exclude, restrict, or modify in any way) any non-excludable statutory warranties in Australia.
3. During the Warranty Period Residentia Group or its ASR will, at no extra charge if your Appliance is readily accessible for service, without special equipment and subject to these terms and conditions, repair or replace any parts which it considers to be defective. Residentia Group or its ASR may use remanufactured parts to repair your Appliance. You agree that any replaced Appliances or parts become the property of Residentia Group. This warranty does not apply to light globes, batteries, seals, filters or similar perishable parts.
4. Parts and Appliances not supplied by Residentia Group are not covered by this warranty.

Warranty Information

5. You will bear the cost of transportation, travel and delivery of the Appliance to and from Residentia Group or its ASR. If you reside outside of the service area, you will bear the cost of:
 - (a) travel of an authorised representative;
 - (b) transportation and delivery of the Appliance to and from Residentia Group or its ASR, in all instances, unless the Appliance is transported by Residentia Group or its ASR, the Appliance is transported at the owner's cost and risk while in transit to and from Residentia Group or its ASR.
 6. Proof of purchase is required before you can make a claim under this warranty.
 7. You may not make a claim under this warranty unless the defect claimed is due to faulty or defective parts or workmanship. Residentia Group is not liable in the following situations (which are not exhaustive):
 - (a) the Appliance is damaged by:
 - (i) accident
 - (ii) misuse or abuse, including failure to properly maintain or service
 - (iii) normal wear and tear
 - (iv) power surges, electrical storm damage or incorrect power supply
 - (v) incomplete or improper installation
 - (vi) incorrect, improper or inappropriate operation
 - (vii) insect or vermin infestation
 - (viii) failure to comply with any additional instructions supplied with the Appliance;
 - (b) the Appliance is modified without authority from Residentia Group in writing;
 - (c) the Appliance's serial number or warranty seal has been removed or defaced;
 - (d) the Appliance was serviced or repaired by anyone other than Residentia Group, an authorised repairer or ASR.
 8. This warranty, the contract to which it relates and the relationship between you and Residentia Group are governed by the law applicable where the Appliance was purchased.
 9. To the extent permitted by law, Residentia Group excludes all warranties and liabilities (other than as contained in this document) including liability for any loss or damage whether direct or indirect arising from your purchase, use or non use of the Appliance.
 10. For Appliances and services provided by Residentia Group in Australia, the Appliances come with a guarantee by Residentia Group that cannot be excluded under the Australian Consumer Law. You are entitled to a replacement or refund for a major failure and for compensation for any other reasonably foreseeable loss or damage. You are also entitled to have the Appliance repaired or replaced if the Appliance fails to be of acceptable quality and the failure does not amount to a major failure. The benefits to you given by this warranty are in addition to your other rights and remedies under a law in relation to the Appliances or services to which the warranty relates.
 11. At all times during the Warranty Period, Residentia Group shall, at its discretion, determine whether repair, replacement or refund will apply if an Appliance has a valid warranty claim applicable to it.
 12. Missing parts are not covered by warranty. Residentia Group reserves the right to assess each request for missing parts in a case by case basis. Any parts that are not reported missing in the first week after purchase will not provide free of charge.
 13. To enquire about claiming under this warranty, please follow these steps:
 - (a) carefully check the operating instructions, user manual and the terms of this warranty;
 - (b) have the model and serial number of the Appliance available;
 - (c) have the proof of purchase (e.g. an invoice) available;
 - (d) telephone the numbers shown below.
 14. You accept that if you make a warranty claim, Residentia Group and its ASR may exchange information in relation to you, in order to enable Residentia Group to meet its obligations under this warranty.
-
- IMPORTANT**
Before calling for service, please ensure the steps in point 13 have been followed.
- CONTACT SERVICE**
1300 11 HELP (4357)
support@residentiagroup.com.au

The Australian Consumer Law requires the inclusion of the following statement with this warranty:

Our goods come with guarantees that cannot be excluded under the Australian Consumer Law. You are entitled to a replacement or refund for a major failure and for compensation for any other reasonably foreseeable loss or damage. You are also entitled to have the goods repaired or replaced if the goods fail to be of acceptable quality and the failure does not amount to a major failure.



EST. 1981

Designed to Enhance

omega

Omega is proudly owned in Australia
by Residentia Group Pty. Ltd.

@residentia.group
www.residentia.group