

# 169 Bottle Wine Cellar Dual Zone

## AESTHETICS

Black Powder Coated Finish
Recessed Aluminium Handle
Black Tinted, UV Triple Glazed Door

## FUNCTIONALITY

Dual Temperature Sensor
Inverter Compressor
Digital Control Panel
Tropical Rated
Ambient Temp. up to 43°C
2 × Internal LED Lights (fade-in / -out)
Zero Clearance Hinge
50-80% Humidity Control
Anti-vibration
Reversible Door
Child Lock Safety
Unique Lock System (10 Kinds)

## STORAGE CAPACITY

Bottle Capacity	169 Bottles
Total Capacity	430L

## TEMPERATURE RANGE

Upper Zone	4°C to 18°C
Lower Zone	8°C to 22°C

## ACCESSORIES

14 × Timber Shelves (Beech)
Including 5 × Telescopic Runners
Including 1 × Display Shelf

## CLEANING

Easy to Clean Exterior
Easy to Clean Glass Doors
Automatic Defrost

## WEIGHT (KG)

Net: 96kg	Gross: 114kg
-----------	--------------

## MAX NOISE LEVEL

Quiet 39 dB(A) Operation
--------------------------

## SIZE, W/D/H (MM)

Packaged:	654 × 764 × 1815
Physical:	595 × 680 × 1788

## INSTALLATION

Integrated or Freestanding	
Door Open Angle:	115°
Door Open Width:	840 mm
Top Clearance	Minimum 2.5cm
Side Clearance	0-5mm

## POWER REQUIREMENTS

Power Connection	10 Amp, Plug
Rated Voltage	220-240V / 50Hz
Power Consumption	0.953 Wh/24h

## ADDITIONAL DETAILS

Barcode	9349260095311
Warranty	3 Years

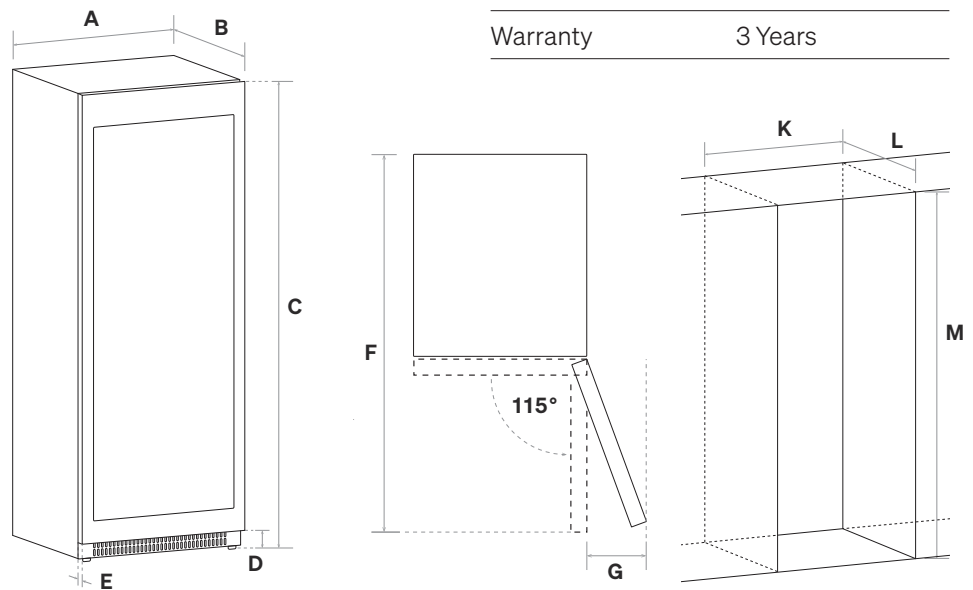

## FRONT VIEW

Note: See the user manual for detailed ventilation and installation details

## DIMENSIONS (MM)

A	595	C	1788-1848	E	48	G	245	L	680
B	680	D	83	F	1291	K	595-600	M	1813-1889