

MD110H80/W-AU

8kg Heat Pump Dryer | MD110 Series | White



FEATURES

Colour	White	
Capacity	8kg	
Display	White LED	
Control Interface	Haptic Dial Touch Button	
No. of Programs	15	
Motor Type	Universal	
Porthole Diameter	375mm	
Drum Light	Yes	
Water Drainage	Tank Plumbed	
Drying Programs	Cotton Synthetics Eco Mix Jeans Wool Refresh Airfresh	Time Dry Sports Shirts Health Guard Bed Linen Towel Delicate Quick 35'
Aux Functions	Dry Level Anti-Crease Lamp Time +/- Delay End Child Lock	

MD110H80/W-AU

8kg Heat Pump Dryer | MD110 Series | White

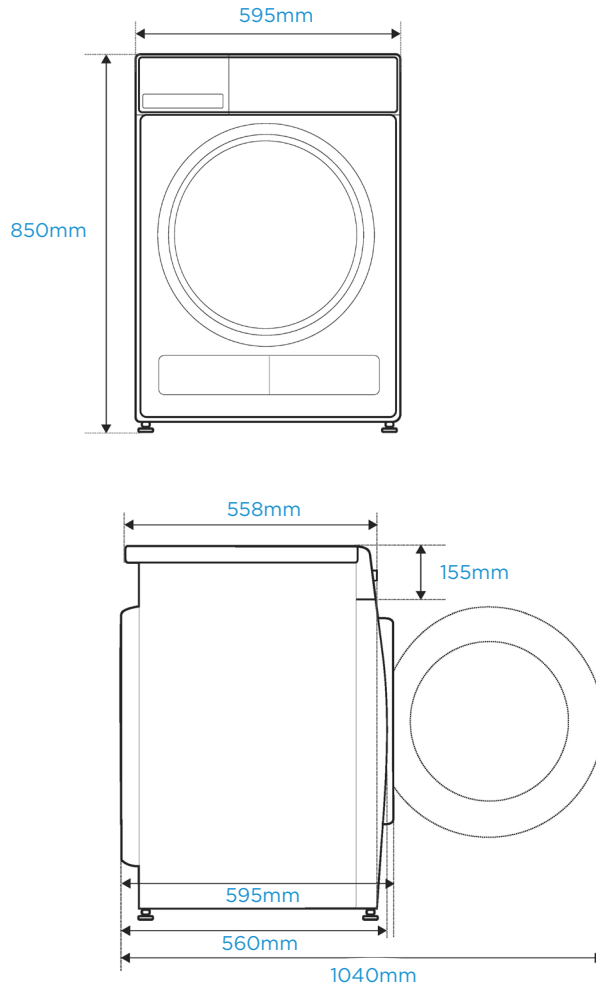

Visit Us

VERSION NO. 20251003

Product and cut-out dimensions are to be used as a guide only. Please refer to actual product before installing or refer to the instruction manual or website for full instructions.

SPECIFICATIONS

Energy Rating	8 ★
Energy Consumption Per Year	135kWh
Electrical Connection	10A Plug & Lead
Power Input & Supply	800W 220-240V ~ 50Hz
Refrigerant Type Quantity	R290 120g
Power Cord Length	1.5m
Drainage Hose Length	2m

PRODUCT & PACKAGING INFORMATION

Carton Dimensions W x D x H	710 x 660 x 890mm
Product Dimensions W x D x H	600 x 595 x 850mm
Gross Weight	48kg
Net Weight	44kg
EAN	6 945878 354029

WARRANTY

Product	3 Years Parts & Labour
---------	------------------------