

Designed to Enhance

EST. 1981

omega

Installation + User Manual

OCI604PPTZ / OCI604TZ / OCI704PPTZ /
/ OCI905TZ / OCI903FTZ

Induction Cooktops

60, 70 & 90cm

Contents

03	Welcome
04	Safety Information
08	Installation Instructions
12	Technical Specifications
17	Control Panel
18	Operating Your Cooktop
20	Cooking Guidelines
30	Care & Maintenance
31	Troubleshooting
33	Purchase Details
34	Warranty Information

Welcome

Residentia Group

Office 165 Barkly Avenue Burnley
Victoria Australia 3121

ACN 70 600 546 656

Online residentia.group
omegaappliances.com.au

Post PO BOX 5177 Burnley
Victoria Australia 3121

Phone 1300 11 4357

Email support@residentia.group

Congratulations on purchasing your new cooktop.

Omega appliances are proudly owned and distributed within Australia by Residentia Group Pty Ltd.

Please refer to the warranty chapter at the rear of this manual for information regarding your product's parts and labour warranty, or visit us online at:

→ residentiagroup.com.au

Here at Residentia Group, we are customer obsessed and our Support Team are there to ensure you get the most out of your appliance. Should you want to learn more about your unit, and importantly, taking care of the appliance, our Support Team are here to help. You can use our online Support Centre at any time by visiting:

→ support.residentiagroup.com.au

Or you can contact us by dialling: 1300 11 HELP (4357)

It is important that you read through the following user manual thoroughly, in order to familiarise yourself with the installation and operation requirements of your appliance, and to ensure optimum performance.

Again, thank you for choosing an Omega appliance and we look forward to being of service to you.

Kind Regards,

The Residentia Team

Customer Care

At Residentia Group, we strongly encourage the use of authentic spare parts to guarantee the best results. When contacting our spare parts team through 1300 11 HELP, or by emailing parts@residentiagroup.com.au, ensure that you have the model and serial numbers on hand, which are found on your appliances' rating plate.

Safety Information

Important Safety Instructions

Read Carefully and Keep for Future Reference

Read this manual thoroughly before first use, even if you are familiar with this type of product. The safety precautions enclosed herein reduce the risk of fire, electric shock and injury when correctly adhered to. Make sure you understand all instructions and warnings.

Keep the manual in a safe place for future reference, along with the completed warranty card and purchase receipt. If you sell or transfer ownership of this product, pass on these instructions to the new owner.

Always follow basic safety precautions and accident prevention measures when using an electrical appliance. The following statements you will see in this booklet have these meanings:

WARNING: Indicating information concerning your personal safety.

CAUTION: Indicating information on how to avoid damaging the appliance or cabinetry.

IMPORTANT: Indicating tips and information about use of the appliance.

Usage Conditions and Restrictions

- Domestic use only: This appliance is intended for indoor household use only. It is not intended for commercial, industrial or outdoor use. It is not intended for use in a recreational vehicle.
- Purpose: Do not use this appliance for anything other than its intended purpose. Other uses are not recommended and may cause fire, electric shock or personal injury.
- Attachments: The use of attachments is not recommended by the appliance manufacturer and distributor as they may be hazardous.
- Improper use: Damage due to improper use, or repairs made by unqualified personnel will void your warranty. We assume no liability for any eventual damages caused by misuse of the product or non-compliance with these instructions.

Before Using Your Appliance

This manual explains the proper use of your new Omega Induction Cooktop. Please read this manual carefully before using the product. This manual should be kept in a safe place for handy reference.

This oven is a domestic appliance which has been manufactured and tested to comply with Australian and New Zealand Standards.

This Induction Cooktop must only be installed in accordance with the instructions provided. Incorrect installation may cause harm to persons, damage property and void the product's warranty.

Read the following carefully to avoid damage or injury.

IMPORTANT: Check for any damage or marks. If you find the appliance is damaged or marked, you must report it within 7 days if you wish to claim for damage/ marks under the manufacturer's warranty. This does not affect your statutory rights.

Safety Instructions

Prior to using your Induction Cooktop, please read all safety and operating instructions thoroughly. Please ensure you follow the steps below before using this product:

- This cooktop must only be installed in accordance with the instructions provided. Incorrect installation may cause harm to persons, damage property and void the product's warranty.
- Unpack the appliance but keep all packaging materials until you have made sure the new Induction Cooktop is undamaged and in good working order. We recommend you keep the original packaging for storing your Induction Cooktop when not in use or transporting.

WARNING: Plastic wrapping can be a suffocation hazard for babies and children, so ensure all packaging materials are out of their reach.

Safety Information

Health Hazard

WARNING: Follow these instructions carefully to avoid potential injury or death.

- This appliance complies with electromagnetic safety standards.
- However, persons with cardiac pacemakers or other electrical implants (such as insulin pumps) must consult with their doctor or implant manufacturer before using this appliance to make sure that their implants will not be affected by the electromagnetic field.
- Failure to follow this advice may result in death.

Children & Vulnerable People Safety

WARNING: Risk of suffocation, injury or permanent disability.

This appliance can be used by children aged from 8 years and above and persons with reduced physical, sensory or mental capabilities or lack of experience and knowledge if they have been given supervision or instruction for the operation of the appliance by a person who is responsible for their safety.

- Children should be supervised to ensure that they do not play with, sit, stand, or climb on the appliance.
- Do not store items of interest to children in cabinets above the appliance. Children climbing on the cooktop could be seriously injured.
- Cleaning and user maintenance shall not be made by children without supervision.
- Remove all packaging before using the appliance. Otherwise, serious damage or injury may result.

Cut Hazard

WARNING: Follow these instructions carefully to avoid a potential injury.

- Take care - panel edges are sharp.
- The razor-sharp blade of a cooktop scraper is exposed when the safety cover is retracted. Use with extreme care and always store safely and out of reach of children.
- Failure to use caution could result in injury or cuts.

Electrical Connection

WARNING: Risk of fire and electrical shock!

It is important to use your cooktop safely. Follow these instructions carefully to avoid potential electric shock, fire or death.

- In certain circumstances electrical appliances may be a safety hazard. Check the conformity of voltage and power settings, which are specified on the information plate attached to the appliance and/or packaging, with the usage conditions available.
- Disconnect the appliance from the mains electricity supply before carrying out any work or maintenance on it.
- A means for disconnection must be incorporated in the fixed wiring in accordance with the wiring rules.
- If the appliance is being hardwired, it must be installed by an authorised technician.
- Do not cook on a broken or cracked cooktop. If the cooktop surface should break or crack, switch the appliance off immediately at the mains power supply (wall switch) and contact a qualified technician.
- The electrical connection must be accessible after installation.

WARNING: If the supply cord is damaged, it must be replaced by the manufacturer or its service agent or similarly qualified person in order to avoid a hazard.

WARNING: All electrical work must be done in accordance with local and national electrical codes as applicable and should be undertaken by licenced and qualified persons only. Failure to follow these instructions can result in death, fire or electrical shock.

Cracked Surface

WARNING: If the surface is cracked, switch off the appliance to avoid the possibility of electric shock, for cooktop surfaces of glass-ceramic or similar material which protect live parts.

Safety Information

Before Installation

- To avoid a hazard, this appliance must be installed according to the instructions in this user manual for installation. Failure to install the appliance correctly could invalidate any warranty or liability claims.
- This appliance should be connected to a circuit which incorporates an isolating switch providing full disconnection from the power supply.
- All cabinetry and materials used in the installation must be able to withstand a minimum temperature of 50°C above the ambient temperature of the room it is located in, whilst in use.
- Certain types of vinyl or laminate kitchen furniture are particularly prone to heat damage or discolouration at temperatures below the guidelines given above.
- Any damage caused by the appliance being installed without adhering to the temperature limits set out above will be the liability of the owner. To avoid any hazards, limit access to the under-bench section of the cooktop.
- Damage can occur to bench tops if pots and pans are allowed to overlap the bench top. This can result in heat being transferred to the bench top.
- Ensure that correct sized pots & pans are used. Pans should be lifted on and off the cooktop surface and not dragged. Cooking zones should not be switched on without cookware placed on it. Do not place empty cookware onto the cooking zones when in use.
- Please contact 1300 11 HELP (4357) to arrange an authorised technician.

Appliance Use

- The appliance and its accessible parts become hot when in use.
- Care should be taken to avoid touching heating elements.
- **WARNING:** Unattended cooking on a cooktop with fat or oil can be dangerous and may result in a fire. Never try to extinguish a fire with water, but switch off the appliance and then cover flame e.g. with a lid or a fire blanket.
- The cooking process has to be supervised. A short term cooking process must always be supervised at all times. Boilover causes smoking and greasy spillovers that may ignite.
- The appliance and its accessible parts become hot during use. Care should be taken to avoid touching heating elements
- Do not store items on the cooking surfaces.
- Never leave any objects or utensils on the appliance. Metallic objects such as knives, forks, spoons and lids should not be placed on the cooktop surface since they can get hot
- The appliance is not intended to be operated by means of an external timer or separate remote-control system.
- Do not place heavy objects on the appliance, use for storage or as a cutting surface as sharp edges can damage the surface.
- This appliance is designed for cooking food only.
- Use flat based, stable, induction compatible cookware only.
- Only use cooktop guards designed by the manufacturer of the cooking appliance or indicated by the manufacturer of the appliance in the instructions for use as suitable or cooktop guards incorporated in the appliance. The use of inappropriate guards can cause accidents.
- No combustible material or products should be placed on this appliance at any time.
- During use, accessible parts of this appliance will become hot enough to cause burns.
- Do not let your body, clothing or any item other than suitable cookware contact the Induction glass until the surface is cool.

Safety Information

- Handles of saucepans may be hot to touch. Check saucepan handles do not overhang other cooking zones that are on. Keep handles out of reach of children. Failure to follow this advice could result in burns and scalds.
- Never use your appliance as a work or storage surface.
- Do not place or leave any magnetic objects (e.g. credit cards, memory cards) or electronic devices (e.g. computers, mobile phones) near the appliance, as they may be affected by its electromagnetic field.
- Never use your appliance for warming or heating the room.
- After use, always turn off the cooking zones and the cooktop as described in this manual (i.e. by using the touch controls). Do not rely on the pan detection feature to turn off the cooking zones when you remove the pans.
- Do not place or drop heavy objects or stand on your cooktop.
- Do not use pans with jagged edges or drag pans across the Induction glass surface as this can scratch the glass.
- Ensure that the kitchen is well ventilated or mechanical ventilation is in use while cooking on this appliance.
- Do not store or use flammable materials or aerosols near the cooktop. Items made from aluminium, plastic, plastic film & sugar-based foods should also be kept away from the appliance, as they may fuse to the surface.
- **WARNING:** The surface temperature of this appliance exceeds 95°C. To avoid a hazard, under bench access must be restricted. A board must be installed underneath the cooktop. Heat from the underside of the unit will be expelled by inbuilt fans – do not block.
- **WARNING:** The cooktop will become hot during and directly after use. Do not touch the surface during this time, as it may be hot and can cause burns. To avoid burns and injury, children should be kept away.
- Do not modify this appliance

Care & Cleaning

CAUTION: Risk of injury or damage to the cooktop.

- Cleaning may only be commenced on the appliance once it has cooled down and is turned off. Failure to clean properly can damage the cooktop.
- Do not use a steam clean, steam jet or any other high-pressure cleaning equipment to clean the appliance.
- Do not use scourers or any other harsh abrasive cleaning agents to clean your cooktop, as these can scratch the ceramic glass.
- Clean the appliance with a moist soft cloth. Only use neutral detergents. Do not use abrasive products, abrasive cleaning pads, solvents or metal objects.
- Do not use harsh abrasive cleaners or sharp metal scrapers to clean the glass since they can scratch the surface, which may result in glass damage.

Unpacking

- During transportation, protective packaging was used to protect the appliance against any damage. After unpacking, please dispose of all elements of packaging in a way that will not cause damage to the environment.
- All materials used for packaging the appliance are environmentally friendly; they are 100% recyclable and are marked with the appropriate symbol.

CAUTION: During unpacking, the packaging materials (polythene bags, polystyrene pieces, etc.) should be kept out of reach of children.

Safety Information

Disposal of the Appliance

- Disconnect the appliance from the mains supply.
- Cut off the mains cable and discard it.
- Old appliances should not simply be disposed of with normal household waste and should be delivered to a collection and recycling centre for electric and electronic equipment. A symbol shown on the product, the instruction manual or the packaging shows that it is suitable for recycling.

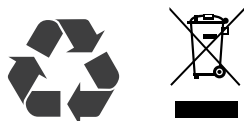

- The packaging is designed to protect the appliance from damage during transportation. The packaging materials are environmentally friendly and should be recycled. Recycling the packaging can reduce the use of raw materials in the manufacturing process and the amount of waste in landfill sites
- Packaging materials of the product are manufactured from recyclable materials in accordance with our National Environment Regulations. Do not dispose of the packaging materials together with the domestic or other wastes. Take them to the packaging material collection points designated by the local authorities.
- Materials used inside the appliance are recyclable and are labelled with information concerning this. By recycling materials or other parts from used devices you are making a significant contribution to the protection of our environment.
- Information on appropriate disposal centres for used devices can be provided by your local authority.

Declaration of Compliance

When you have unpacked the cooktop, make sure that it has not been damaged in any way. If you have any doubts at all, do not use it: contact a professionally qualified person. Keep packing materials such as plastic bags, polystyrene, or nails out of the reach of children because these are dangerous to children.

Installation Instructions

Important Safety Instructions

- **IMPORTANT:** If your appliance doesn't include a 10 amp power plug. It must be installed by an authorised technician or similarly qualified person. If you wish to arrange an authorised technician please contact our friendly support team at 1300 11 4357 or by visiting the portal at support.residentiagroup.com.au.
- Make sure to check the condition of the appliance after unpacking it. Do not continue with installation if it has been damaged during transport.
- The work surface must be square and level, and no structural members interfere with space requirements.
- **WARNING:** The work surface material must be made of a heat-resistant material.
- If the cooktop is installed above an oven, the oven must have a built-in cooling fan.
- The installation must comply with all clearance requirements and applicable standards and regulations.
- A suitable isolating switch providing full disconnection from the mains power supply must be incorporated in the permanent wiring, mounted and positioned to comply with the local wiring rules and regulations.
- The isolating switch must be of an approved type and provide a 3mm air gap contact separation in all poles (or in all active [phase] conductors if the local wiring rules allow for this variation of the requirements).
- The isolating switch must be easily accessible to the customer with the cooktop installed
- Please consult with your local building authorities and by-laws if in doubt regarding installation.
- Ensure that you use heat-resistant and easy-to-clean finishes (such as ceramic tiles) for the wall surfaces surrounding the cooktop.
- Cut out the work surface must be according to the sizes specified in this user manual.
- Ensure power to the appliance has been shut off before carrying out any installation or maintenance.

Installation Instructions

Preparing the Cut-Out

Cut-Out Dimensions for 60cm, 70cm & 90cm Cooktops:

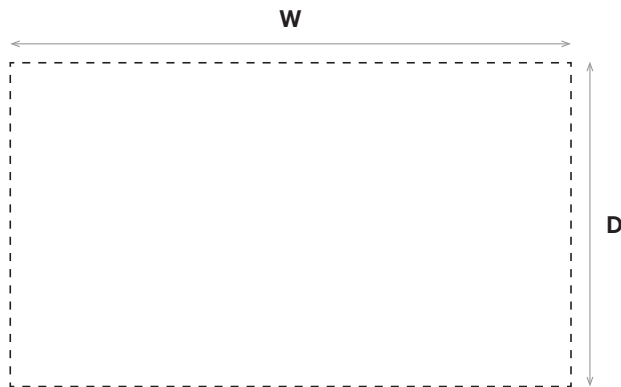

Model	Width (W)	Depth (D)
OCI604PPTZ	560mm	490mm
OCI604TZ	560mm	490mm
OCI704PPTZ	560mm	490mm
OCI905TZ	860mm	490mm
OCI903FTZ	860mm	490mm

- The bench cut-out should be made as per the relevant cutout dimensions shown above. It is most critical that the cut-out chosen corresponds to your cooktop model.
- A minimum of 50mm clearance space around the cut out must be met when installing the appliance.
- To ensure clearances to combustible surfaces observe the minimum distance requirements, follow the relevant information shown in the above table, corresponding to your model.
- Be sure the thickness of the work surface is at least 30mm. Please select heat-resistant and insulated work surface material (Wood and similar fibrous or hygroscopic material shall not be used as work surface material unless impregnated) to avoid the electrical shock and larger deformation caused by the heat radiation from the hotplate.

- Under all circumstances, make sure the cooktop is well ventilated and the air inlet and outlet are not blocked. Ensure the cooktop is in good working state.
- A barrier must be installed to prevent accidental contact with the cooktop base, where the base of the cooktop is accessible from below (i.e. Inside a cupboard, etc.).
- A minimum clearance of 50mm must be maintained between the base and the barrier. This barrier may be made of any non-combustible, rigid material.
- Barrier protection is not necessary if the product is installed above an underbench oven or similar appliance and/or if the cupboard construction is such that the underside of the cooktop is not accessible.
- Ensure that the power supply cable is not accessible through cupboard doors or drawers.
- Ensure that there is adequate flow of air from outside the cabinetry to the base of the cooktop.
- The isolating switch is easily accessible by the customer.
- **WARNING:** Do not use any kind of silicon sealant to seal the appliance against the benchtop. This will make it difficult to remove the appliance, which must be accessible for the service agent to perform any necessary repairs in the future.
- Clamps and screws are supplied with your cooktop. Fit the pull down clamps supplied to ensure that the cooktop cannot move after installation. Refer to the diagram shown below, and the relevant instructions.
- The safety distance between the sides of the cooktop and the inner surfaces of the worktop should be at least 3mm.

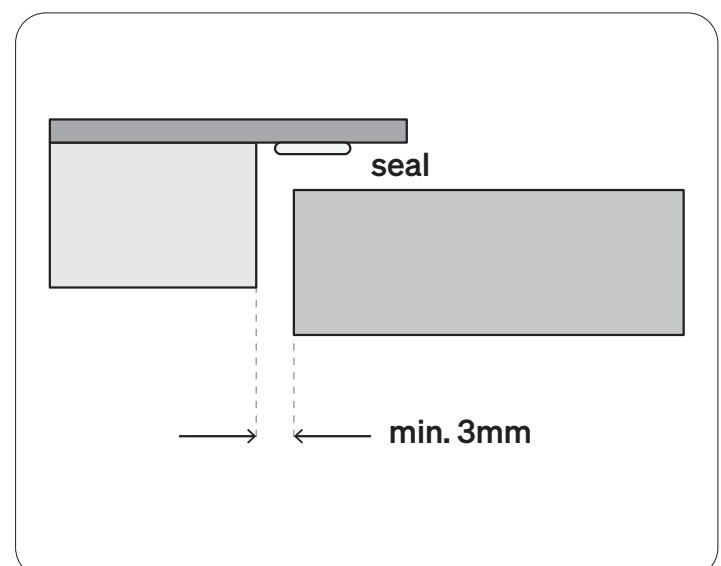

Installation Instructions

Ensuring Adequate Ventilation

***NOTE:** Please refer to your rangehood's user manual for the exact minimum clearances from the top of the cooktop surface to your rangehood.

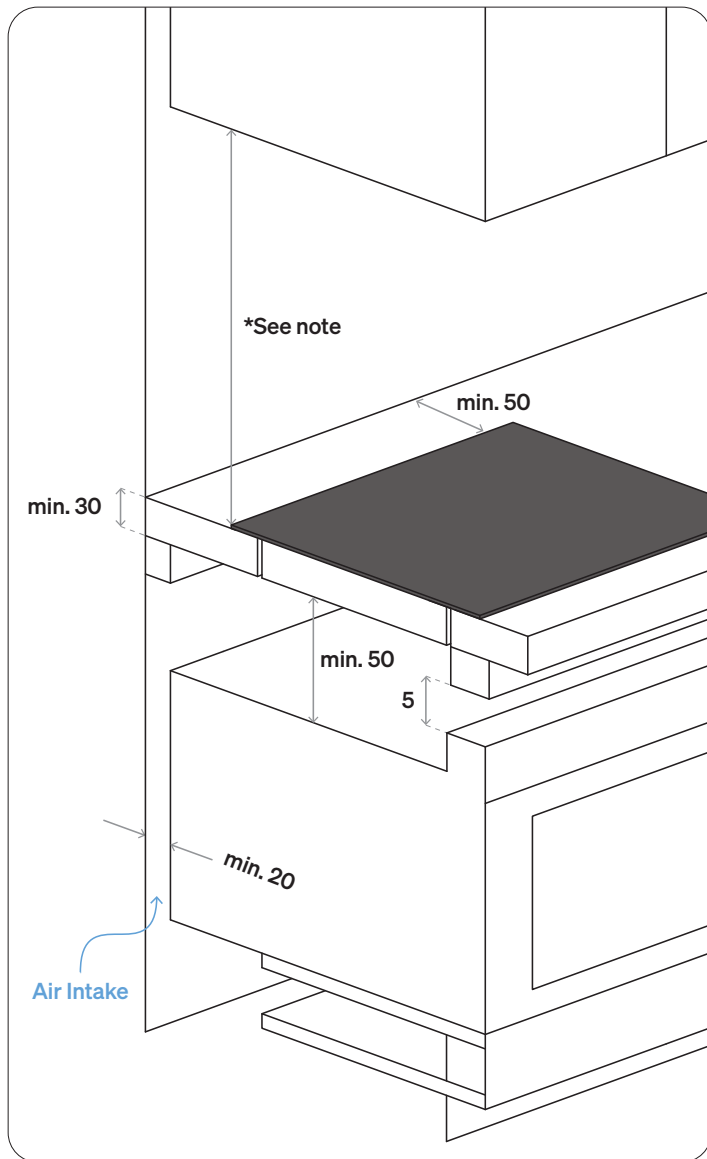

The measurements in the diagram above is in millimetres (mm).

IMPORTANT: Regarding adjacent walls, cupboards and protection for combustible materials: Always ensure that the appliance is installed in accordance with AS/NZS 5601.1, or AS/NZS 5601.2 with regard to clearances to combustible surfaces and materials, and clearances to rangehoods and exhaust fans.

Note: The diagrams in this user manual are for explanatory purposes only. Your appliance and parts may appear differently.

Applying the Fixing Brackets

The unit should be placed on a stable, smooth surface (such as the packaging). Do not apply force onto any controls if they protrude from the cooktop. Fix the cooktop on the work surface by screwing in the four brackets on the bottom of cooktop after installation (see diagram below).

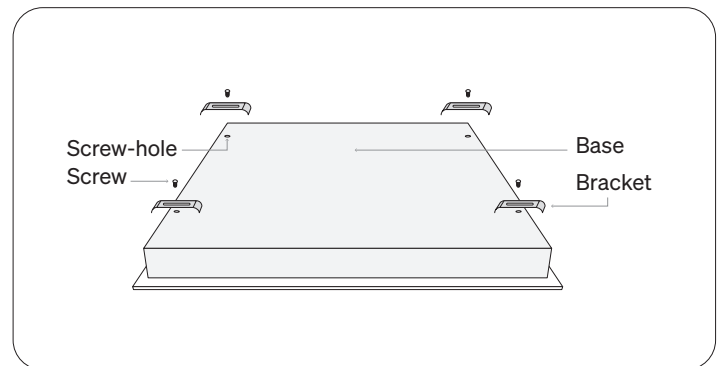

Applying the Fixing Brackets

IMPORTANT: When applying the brackets, ensure you adjust the brackets' position to suit your particular work surface's thickness. Under no circumstances are the brackets to touch with the inner surfaces of the worktop after installation (see diagrams below).

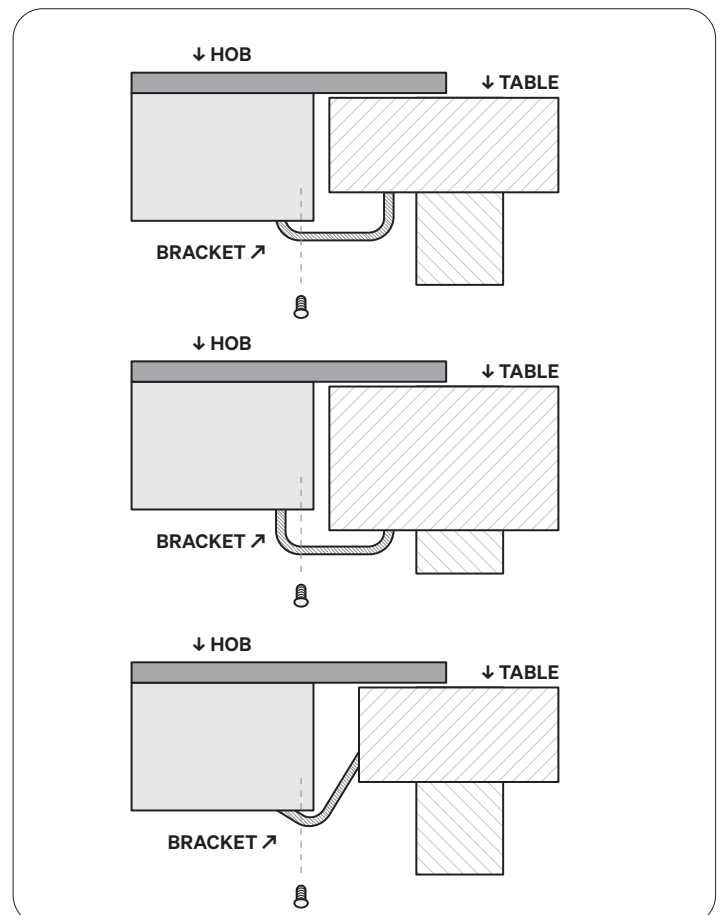

Installation Instructions

Electrical Connection

If your cooktop doesn't come with a 10 amp power plug, the power supply should be connected in compliance with the relevant standard, or a single-pole circuit breaker.

Please refer to the method of connection shown below relevant to your cooktop model.

- If the cable is damaged or needs replacing, this should be done by an after-sales technician using the proper tools, so as to avoid any accidents.
- If the appliance is being connected directly to the mains supply, an omnipolar circuit breaker must be installed with a minimum gap of 3mm between the contacts.
- The installer must ensure that the correct electrical connection has been made and that it complies with safety regulations.
- The cable must not be bent or compressed.
- The cable must be checked regularly and only replaced by a proper qualified person.

For model OCI604TZ

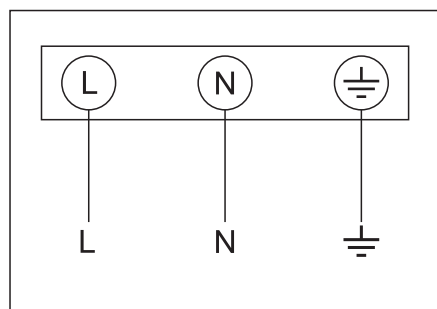

L-N: 220-240V~

For models OCI604PPTZ & OCI704PPTZ

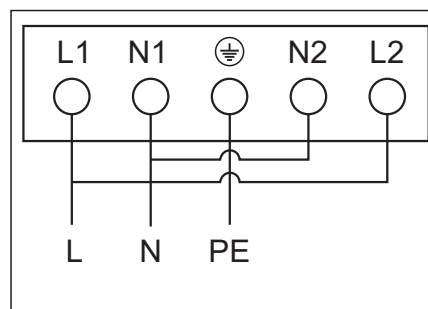

L-N: 220-240V~

For model OCI905TZ

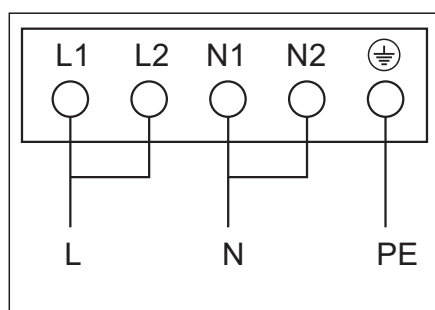

L-N: 220-240V~

For model OCI903FTZ

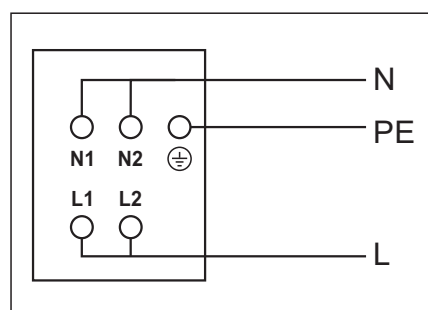

L-N: 220-240V~

Technical Specifications

Specifications Chart: OCI604PPTZ

Model Number	OCI604PPTZ
Cooktop Finish	Black EuroKera® Ceramic Glass with Midnight Side Trim
Controls	Touch Controls
Power Levels	9 Power Levels + Boost
Rated Voltage	220–240V~
Rated Frequency	50 Hz or 60 Hz
Installed Electric Power	2400 W
Cooking Zones	4 Zones
Ø160mm Cooking Zone Output (×2)	Max. 1200 / 1500 W
Ø180mm Cooking Zone (×1)	Max. 1800 / 2100 W
Ø210mm Cooking Zone (×1)	Max. 1800 / 2100 W
Auto-off Safety	120 Minutes
Power Connection	10 Amp, Plug & Play
Power Cord Length	100 cm
Product Weight (Net / Gross)	8.5 kg / 10.5 kg
Dimensions (W × D × H)	590 × 520 × 58 mm
Cut-Out Dimensions (W × D)	560 × 490 mm

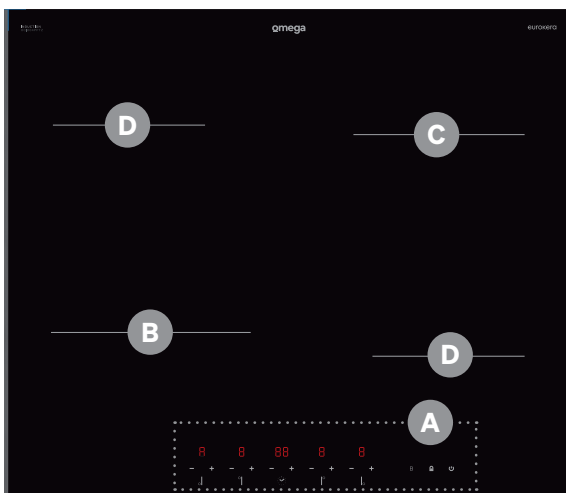

Key

- A. Control Panel
- B. Ø210mm Cooking Zone (Max. 1800 / 2100 W)
- C. Ø180mm Cooking Zone (Max. 1800 / 2100 W)
- D. Ø160mm Cooking Zone (Max. 1200 / 1500 W)

Technical Specifications

Specifications Chart: OCI604TZ

Model Number	OCI604TZ
Cooktop Finish	Black EuroKera® Ceramic Glass with Midnight Side Trim
Controls	Touch Controls
Power Levels	9 Power Levels
Rated Voltage	220–240V~
Rated Frequency	50 Hz or 60 Hz
Installed Electric Power	6400 W
Cooking Zones	4 Zones
Ø160mm Cooking Zone Output (×2)	1400 W
Ø180mm Cooking Zone Output (×2)	1800 W
Auto-off Safety	120 Minutes
Power Connection	30 Amp Limitation, Hardwired
Power Cord Length	100 cm
Product Weight (Net / Gross)	7.6 kg / 9.6 kg
Dimensions (W × D × H)	590 × 520 × 58 mm
Cut-Out Dimensions (W × D)	560 × 490 mm

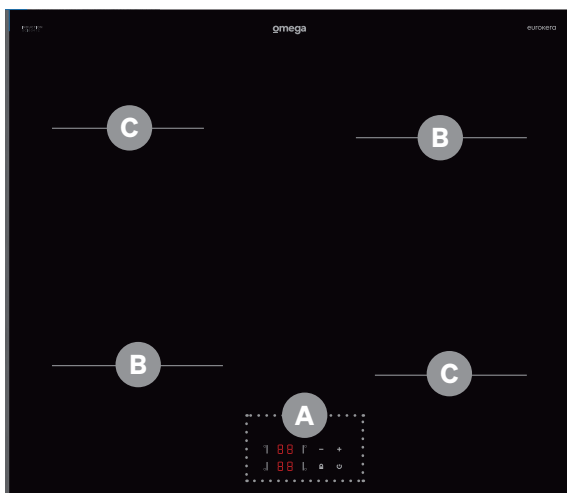

Key

- A. Control Panel
- B. Ø180mm Cooking Zone (Max. 1800 W)
- C. Ø160mm Cooking Zone (Max. 1400 W)

Technical Specifications

Specifications Chart: OCI704PPTZ

Model Number	OCI704PPTZ
Cooktop Finish	Black Schott Ceran® Ceramic Glass with Midnight Side Trim
Controls	Touch Controls
Power Levels	9 Power Levels + Boost
Rated Voltage	220–240V~
Rated Frequency	50 Hz or 60 Hz
Installed Electric Power	2400 W
Cooking Zones	4 Zones
Ø160mm Cooking Zone Output (×2)	1200 / 1500 W
Ø180mm Cooking Zone Output (×1)	1800 / 2100 W
Ø210mm Cooking Zone Output (×1)	1800 / 2100 W
Auto-off Safety	120 Minutes
Power Connection	10 Amp, Plug & Play
Power Cord Length	100 cm
Product Weight (Net / Gross)	8.9 kg / 10.9 kg
Dimensions (W × D × H)	700 × 520 × 58 mm
Cut-Out Dimensions (W × D)	560 × 490 mm

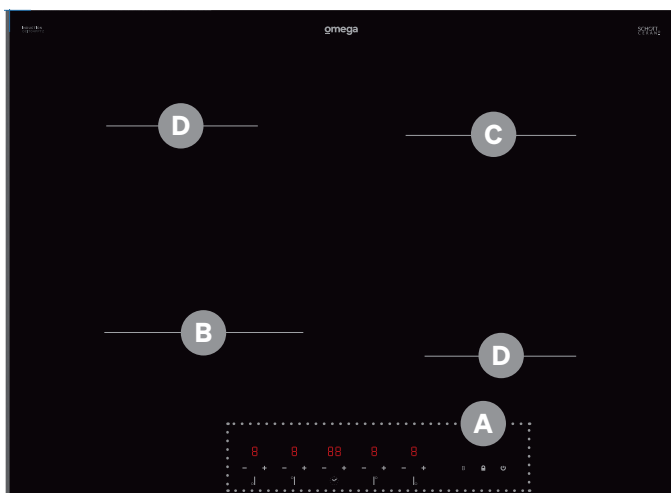

Key

- A. Control Panel
- B. Ø210mm Cooking Zone (Max. 1800 / 2100W)
- C. Ø180mm Cooking Zone (Max. 1800 / 2100W)
- D. Ø160mm Cooking Zone (Max. 1200 / 1500W)

Technical Specifications

Specifications Chart: OCI905TZ

Model Number	OCI905TZ
Cooktop Finish	Black Schott Ceran® Ceramic Glass with Midnight Side Trim
Controls	Touch & Slide Controls
Power Levels	9 Power Levels + Boost
Rated Voltage	220–240V~
Rated Frequency	50 Hz or 60 Hz
Installed Electric Power	9300 W
Cooking Zones	5 Zones
Ø210mm Cooking Zone Output (×2)	1800 / 2100 W
Ø180mm Cooking Zone Output (×1)	1800 / 2100 W
Ø160mm Cooking Zone Output (×2)	1200 / 1500 W
Auto-off Safety	120 Minutes
Power Connection	38.75 Amp, Hardwired
Power Cord Length	100 cm
Product Weight (Net / Gross)	15 kg / 17.8 kg
Dimensions (W × D × H)	900 × 520 × 58 mm
Cut-Out Dimensions (W × D)	860 × 490mm

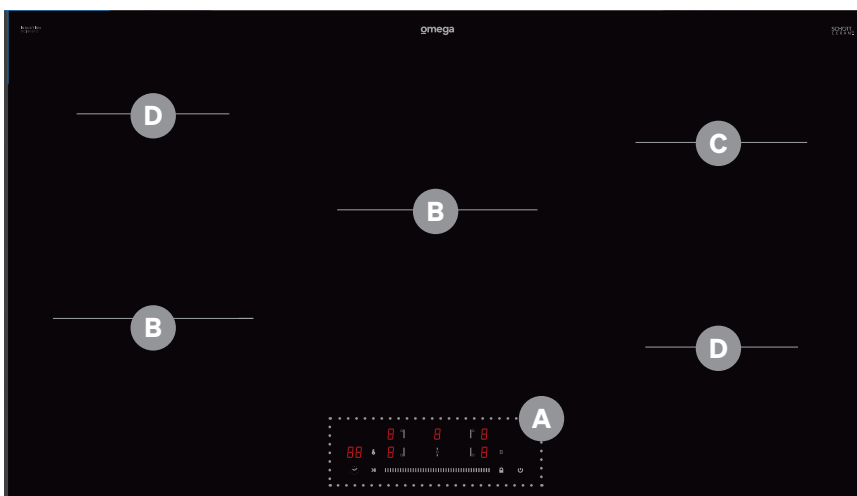

Key

- A. Control Panel
- B. Ø180mm Zone (Max. 1800 / 2100W)
- C. Ø180mm Zone (Max. 1800 / 2100W)
- D. Ø210mm Zone (Max. 1200 / 1500W)

Technical Specifications

Specifications Chart: OCI903FTZ

Model Number	OCI903FTZ
Cooktop Finish	Black Schott Ceran® Ceramic Glass with Midnight Side Trim
Controls	Touch & Slide Controls
Power Levels	9 Power Levels + Boost
Rated Voltage	220–240V~
Rated Frequency	50 Hz or 60 Hz
Installed Electric Power	10800 W
Cooking Zones	7 Zones (including 3 FlexZones)
220×190mm Cooking Zone Output (×4)	1800 / 2100 W
Ø280mm Cooking FlexZone Output (×1)	3000 / 4000 W
220×390mm FlexZone Output (×2)	3000 / 3600 W
Auto-off Safety	120 Minutes
Power Connection	45 Amp, Hardwired
Power Cord Length	100 cm
Product Weight (Net / Gross)	17.3 kg / 20.2 kg
Dimensions (W × D × H)	900 × 520 × 58 mm
Cut-Out Dimensions (W × D)	860 × 490mm

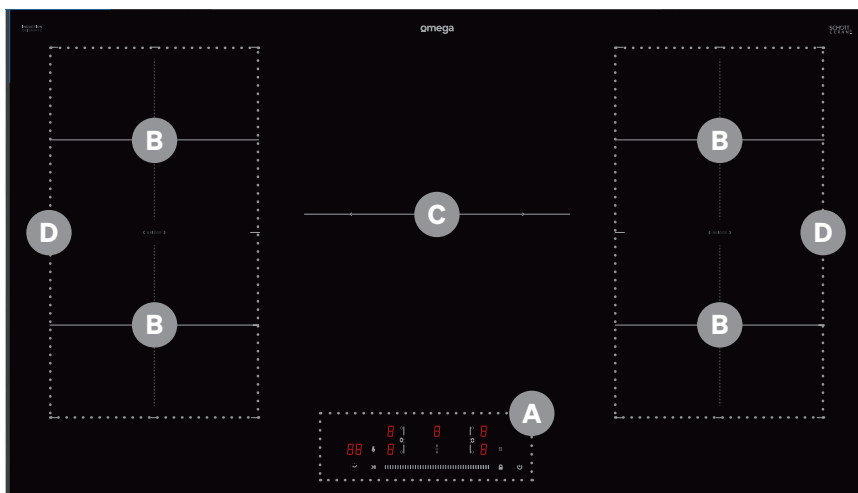

Key

- A. Control Panel
- B. 220×190mm Zone (Max. 1800 / 2100W)
- C. Ø280mm FlexZone (Max. 3000 / 4000W)
- D. 220×390mm FlexZone (Max. 3000 / 3600W)

Control Panel

Key

- | | | |
|------------------------------------|-----------------------|-------------------------|
| A. Power Button | D. Power Boost Button | G. Keep Warm Button |
| B. Power Level Adjustment Controls | E. Child Lock Button | H. Start / Pause Button |
| C. Timer Adjustment / Selector | F. Zone Selector | |

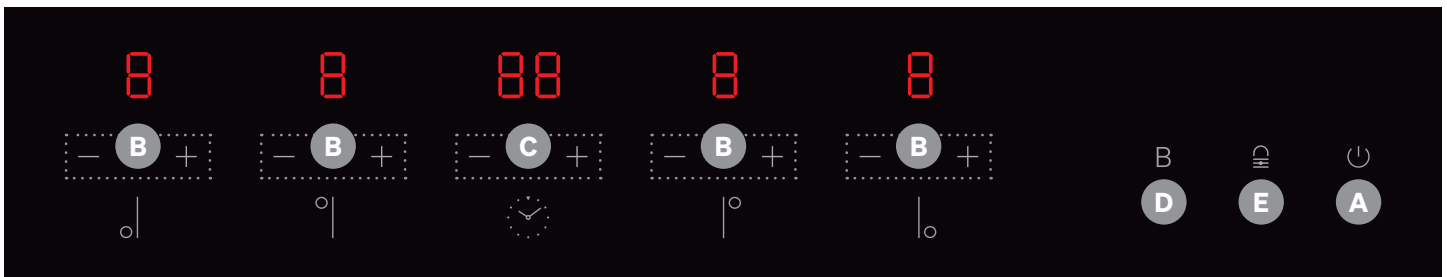

↑ OC1604PPTZ & OC1704PPTZ

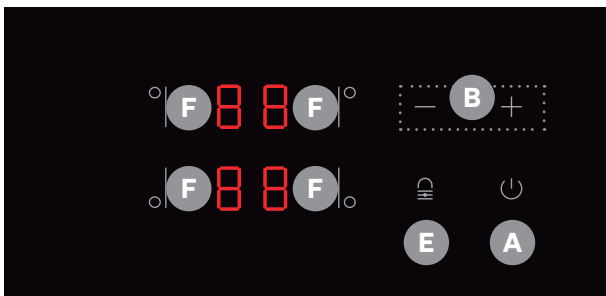

↑ OC1604TZ

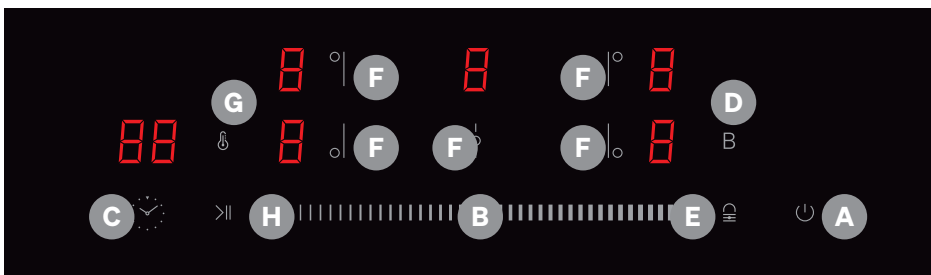

↑ OC1905TZ

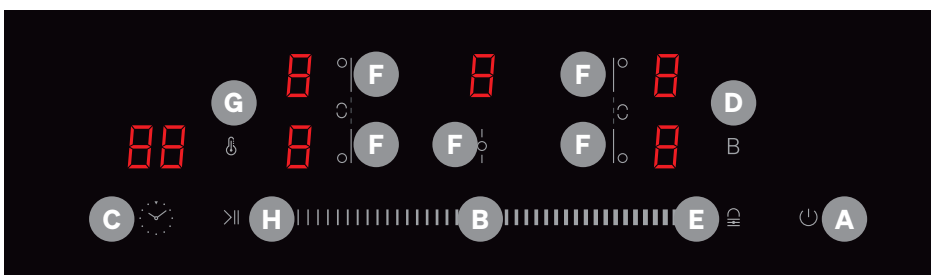

↑ OC1903FTZ

Operating Your Cooktop

Introducing Induction Cooking

This innovative and efficient cooking method is designed to offer safety, advanced functionality, and cost-effectiveness.

Induction cooking operates using electromagnetic vibrations that generate heat directly within the pan, rather than heating the glass surface indirectly. The glass surface only heats up as a consequence of the pan's heat transfer.

Please refer to this manual for comprehensive guidance on using and maximising the benefits of your induction cooker.

Before using the Induction Cooktop

- Read this user manual carefully, taking special note of the 'Safety Information' chapter in particular.
- Ensure you remove any protective film that may still be on your cooktop surface after unpacking.
- The controls respond to touch, so you don't need any pressure. Use the pad of your finger, not the tip.
- You will hear a beep each time a touch is registered.
- Make sure the controls are always clean, dry, and that there is no object (e.g. a utensil or a cloth) on top. Even a thin film of water or food particles may make the controls unresponsive and difficult to operate.

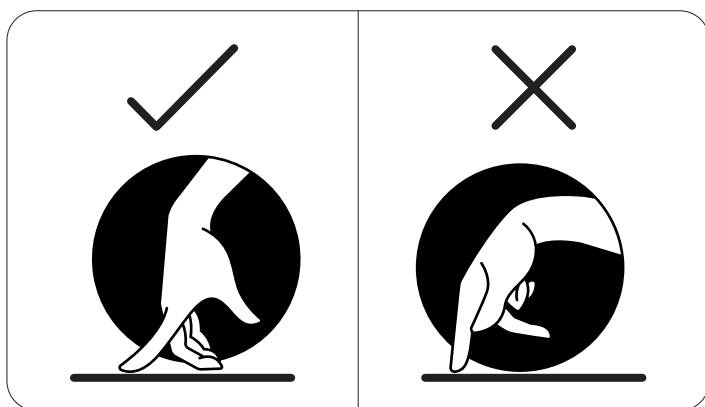

Choice of Burner

Below is a cookware size guide to use on your cooktop's zones:

- **Ø280mm Zone**
Cookware Size: Ø180mm
- **Ø210mm Zone**
Cookware Size: Ø160mm
- **Ø180mm Zone**
Cookware Size: Ø140mm
- **Ø160mm Zone**
Cookware Size: Ø120mm
- **220×190mm Independent Zone**
Cookware Size: Ø160mm
- **220×390mm FlexZone**
Cookware Size: Ø250mm

Verifying Compatibility of Cookware

To determine if your cookware is compatible with induction cooking, you can perform a magnet test. Simply bring a magnet close to the base of the pan. If the magnet is attracted to the pan, it indicates that the pan is suitable for induction use.

In the event that you don't have a magnet available, you can follow these steps:

1. Fill the pan you wish to test with some water.
2. Proceed to start cooking as instructed in the 'Cooking with Your Induction Cooktop' section.
3. If the indicator specified in the manual does not flash on the display and the water begins to heat up, it confirms the suitability of the pan for induction.

Please note that cookware composed solely of materials such as pure stainless steel, aluminum, or copper without a magnetic base, along with glass, wood, porcelain, ceramic, and earthenware, are not compatible with induction cooking.

Operating Your Cooktop

Choosing the Right Cookware

- Do not use cookware with jagged edges, coarse or uneven surfaces, chipped bottoms or a curved base.
- Make sure that the base of your pan is smooth, sits flat against the glass, and is the same size as the cooking zone. Always center your pan on the cooking zone.
- For best practice, gently lift cookware off the glass—avoid sliding them, as the bottom of your cookware may scratch the surface.
- The FlexZone can not only use griddle plates, you can also utilise larger cookware specially designed for that specific area.
- For certain types of induction cookware with incomplete ferromagnetic bases. If the cookware's bottom material includes aluminum, it may result in a reduced ferromagnetic area. Consequently, this could lead to the cookware not reaching adequate heat levels or even being undetectable during operation.

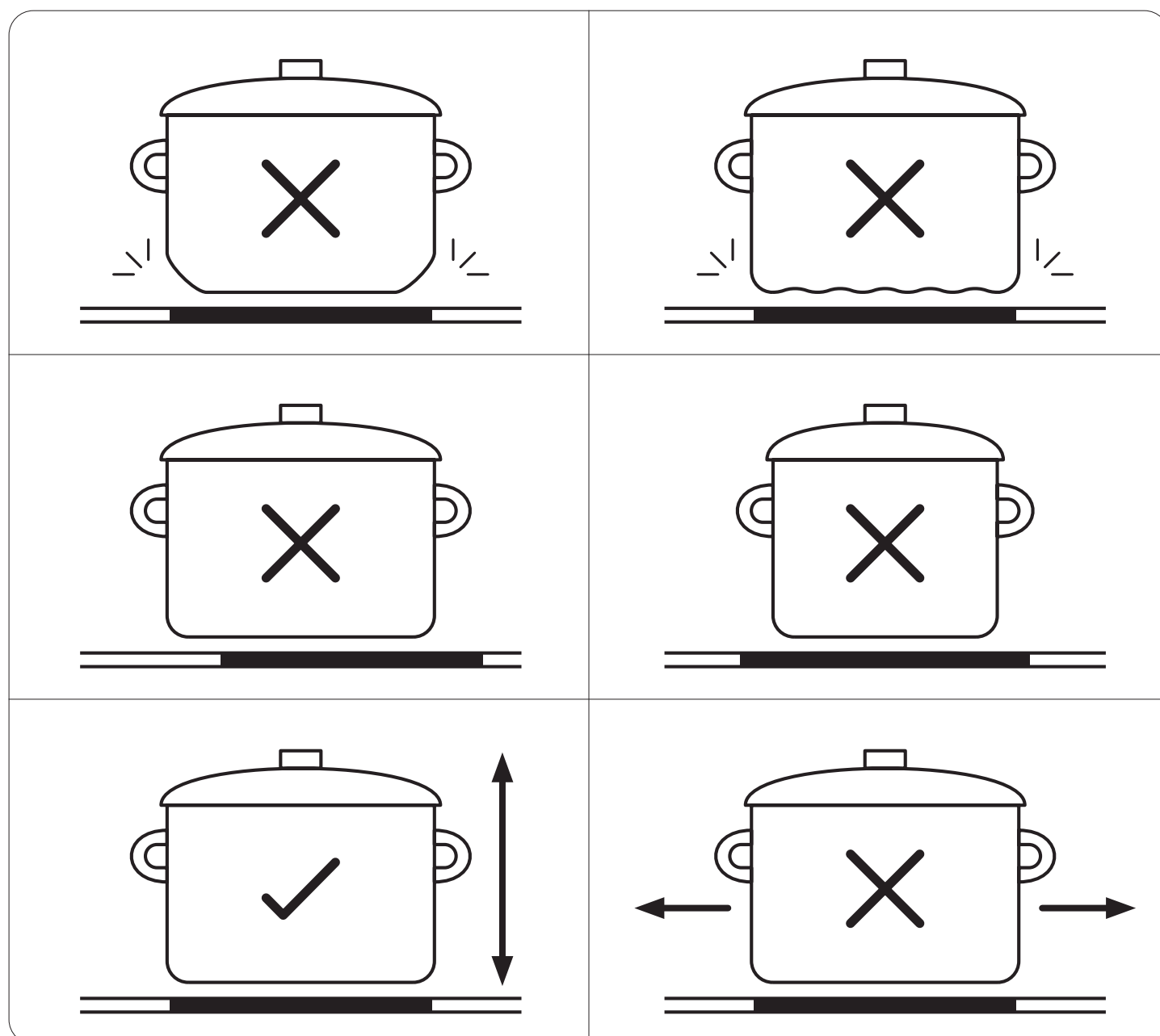

Operating Your Cooktop

Getting Started with Cooking

For models OCI604PPTZ, OCI604TZ & OCI704PPTZ

1. Power On

Activate the cooktop by pressing the Power button. Upon activation, a single beep will sound, and all indicators will briefly display "-" for 1 second before turning off. This indicates that the cooktop has entered standby mode.



2. Preparing the Cooking Surface

Place an induction compatible pan or pot on the desired cooking zone. Please ensure both the bottom of the pan and the cooktop's surface are clean and dry for optimal cooking performance.

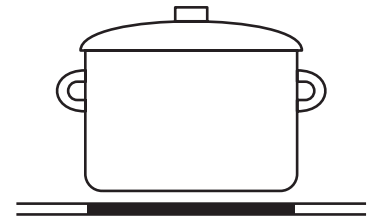

3. Selecting the Cooking Zone (OCI604TZ only)

- For OCI604PPTZ & OCI704PPTZ models, proceed by skipping this step.
- For the OCI604TZ model, simply touch the Zone Selector button beside the desired cooking zone. Subsequently, an indicator adjacent to the selected key will start flashing.



4. Selecting the Cooking Zone & Heat Setting

Touch the Power Level Adjustment Controls "-" & "+" corresponding to your desired cooking area.

Note:

- If you do not adjust the heat setting within 1 minute of selecting the cooking zone, the cooktop will automatically switch off. In such cases, you will need to restart the process from step 1.
- You have the flexibility to modify the power level at any point during cooking.



Operating Your Cooktop

Getting Started with Cooking

For models OCI905TZ & OCI903FTZ

1. Power On

Activate the cooktop by pressing the Power button. Upon activation, a single beep will sound, and all indicators will briefly display "-" for 1 second before turning off. This indicates that the cooktop has entered standby mode.



2. Preparing the Cooking Surface

Place an induction compatible pan or pot on the desired cooking zone. Please ensure both the bottom of the pan and the cooktop's surface are clean and dry for optimal cooking performance.

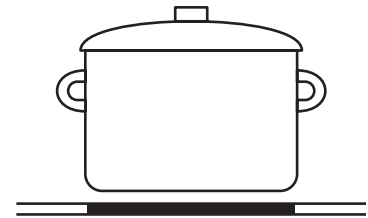

3. Selecting the Cooking Zone

Touch the Zone Selector button beside the desired cooking zone. Subsequently, an indicator adjacent to the selected key will start flashing.



4. Choosing the Heat Setting

After selecting the cooking zone, adjust the power level setting by touch and sliding the Power Level Adjustment Controls. This allows you to set the desired temperature for cooking.

Note:

- If you do not adjust the heat setting within 1 minute of selecting the cooking zone, the cooktop will automatically switch off. In such cases, you will need to restart the process from step 1.
- You have the flexibility to modify the power level at any point during cooking.

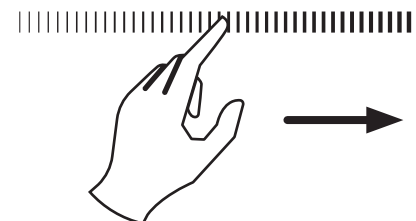

Operating Your Cooktop

When Finished Cooking

For models OCI604PPTZ, OCI604TZ & OCI704PPTZ

1. Switching Off Individual Cooking Zones

Touch the Power Level Adjustment Controls "-" next to the desired cooking zone that you wish to switch off. Keep pressing the "-" button down to "0" on the control for the specific cooking zone. Ensure that the display indicates "0" to confirm the cooking zone has been turned off.

Note:

For Model OCI604TZ, the Zone Selector is required to be selected first before selecting the Power Level Adjustment Controls "-".

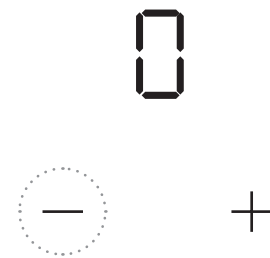

2. Turning Off the Entire Cooktop

To shut down the entire cooktop, touch the Power button control.



3. Caution: Hot Surfaces

After cooking, "H" may display, indicating that the cooking zone is too hot to touch. This symbol will disappear once the surface has cooled to a safe temperature. Additionally, it can serve as an energy-saving feature; you can use the residual heat to further heat other pans or continue cooking without additional power usage.



Operating Your Cooktop

When Finished Cooking

For models OCI905TZ & OCI903FTZ

1. Switching Off Individual Cooking Zones

Touch the Zone Selector button next to the desired cooking zone that you wish to switch off. Subsequently, an indicator adjacent to the selected key will start flashing. Touch and slide the Power Level Adjustment Controls down to "0". Ensure that the display indicates "0" to confirm the cooking zone has been turned off.

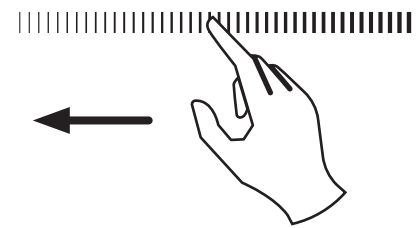

2. Turning Off the Entire Cooktop

To shut down the entire cooktop, touch the Power button control.



3. Caution: Hot Surfaces

After cooking, "H" may display, indicating that the cooking zone is too hot to touch. This symbol will disappear once the surface has cooled to a safe temperature. Additionally, it can serve as an energy-saving feature; you can use the residual heat to further heat other pans or continue cooking without additional power usage.



Operating Your Cooktop

Utilising the Power Boost Function

For models OCI604PPTZ & OCI704PPTZ

1. Selecting the Cooking Zone

Touch the Power Level Adjustment Controls "+" next to the cooking zone featuring the boost function (front left cooking zone).

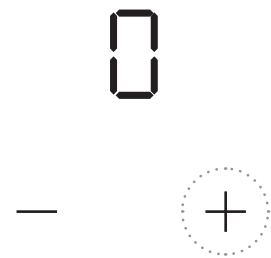

2. Activating Boost Function

Then press and hold the Power Boost button key (B) until the power level display shows "P".

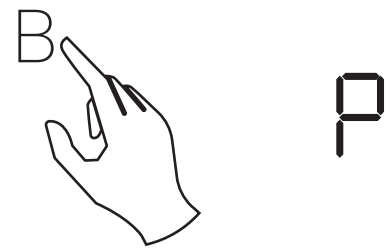

3. Cancelling the Boost Function

Touch the Power Level Adjustment Controls "-" next to the the zone featuring the boost function (front left cooking zone) and choose the desired power level.

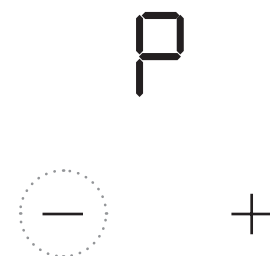

Note:

- The Boost function operates for a maximum of 5 minutes. Afterward, the zone will automatically revert to level 9.
- Model OCI604TZ does not support the Power Boost function.

A digital display showing the number '9'.

Operating Your Cooktop

Utilising the Power Boost Function

For models OCI905TZ & OCI903FTZ

1. Selecting the Cooking Zone

Touch the Zone Selector button next to the cooking zone featuring the boost function (front left cooking zone).



2. Activating Boost Function

Then press and hold the Power Boost button key (B) until the power level display shows "P".

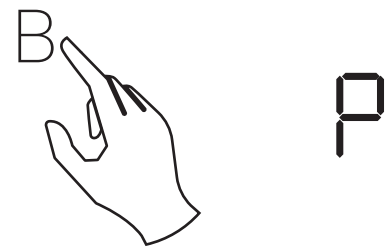

3. Cancelling the Boost Function

Touch and slide the Power Level Adjustment Controls down and choose the desired power level.

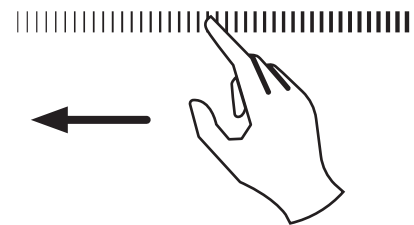

Note:

- The Boost function operates for a maximum of 5 minutes. Afterward, the zone will automatically revert to level 9.

9

Operating Your Cooktop

Using the Timer Function

Model OCI604TZ does not support the Timer function.

The Timer function can be used in two ways, either as a minute minder (kitchen timer), or as a way to automatically turn off cooking zones after a set period of time. The timer can be set up to 99 minutes.

Using the Timer as a Minute Minder

NOTE: You can set the minute minder either before or after adjusting the cooking zone power settings.

For models OCI604PPTZ & OCI704PPTZ

- Ensure the cooktop is powered on and the Zone Selection is inactive (no blinking ‘-’ indication).
- Touch the Timer Selector button "+". "00" will appear on the timer display and the first digit will be blinking.
- Adjust time by touching the Timer Adjustment Controls "+" & "-" to increase or decrease by 1 minute.
- Press and hold the timer control to adjust time in increments of 10 minutes.
- Once the time is set, the countdown will start immediately, and the display will indicate the remaining time.
- When the set time elapses, an alert will sound for 30 seconds, and the timer indicator will display "--".

For models OCI905TZ & OCI903FTZ

- Ensure the cooktop is powered on and the zone selection key is inactive (no blinking ‘-’ indication).
- Touch the Timer Selector button. "00" will appear on the timer display and the first digit will be blinking.
- Adjust time for the first digit by touch & sliding the Timer Adjustment Controls.
- Touch the Timer Adjustment Controls again to set the time and second digital will be blinking.
- Adjust time for the second digit by touch & sliding the Timer Adjustment Controls.
- Touch the Timer Adjustment Controls again to set the time.

- Once the time is set, the countdown will start immediately, and the display will indicate the remaining time.
- When the set time elapses, an alert will sound for 30 seconds, and the timer indicator will display "--".

Using the timer to power off one or more cooking zones

For models OCI604PPTZ & OCI704PPTZ

- Select the desired heating zone by touching its Zone Selector button.
- Touch the Timer Selector button "+". "00" will appear on the timer display and the first digit will be blinking.
- Adjust time by touching the Timer Adjustment Controls "+" & "-" to increase or decrease by 1 minute.
- Press and hold the timer control to adjust time in increments of 10 minutes.
- Once the time is set, the countdown starts immediately, showing the remaining time on the display. A red dot on the power level indication signifies the selected zone.
- When the cooking timer reaches zero, the corresponding zone will turn off automatically.

NOTE: Other cooking zones will keep operating if they are turned on previously.

For models OCI905TZ & OCI903FTZ

- Select the desired heating zone by touching its Zone Selector button.
- Touch the Timer Selector. "00" will appear on the timer display and the first digit will be blinking.
- Adjust time for the first digit by touch & sliding the Timer Adjustment Controls.
- Touch the Timer Adjustment Controls again to set the time and second digital will be blinking.
- Adjust time for the second digit by touch & sliding the Timer Adjustment Controls.
- Touch the Timer Adjustment Controls again to set the time.

Operating Your Cooktop

- Once the time is set, the countdown starts immediately, showing the remaining time on the display. A red dot on the power level indication signifies the selected zone.
- When the cooking timer reaches zero, the corresponding zone will turn off automatically.

NOTE: Other cooking zones will keep operating if they are turned on previously.

Using the timer to power off multiple cooking zones

- If setting timers for multiple zones, the relevant cooking zones will display red dots, indicating the activated timers. The timer display will show the minimum set timer, and the corresponding zone's dot will blink.
- Upon expiration of a zone's timer, that specific zone will switch off. The display will then show the new minimum timer, and the dot of the corresponding zone will flash.

Canceling the Timer:

- Select the heating zone for which you want to cancel the timer.
- Touch the timer control; the indicator will flash.
- Press the “-” control until the timer shows “00” to cancel the timer for the selected zone.

Residual Heat Warning

When the cooktop has been operating for some time, there will be some residual heat. The letter “H” appears to warn you to keep away from it.



Using the Child Lock Function

To prevent unintended use, such as accidental activation by children, you can activate the Child Lock feature. When locked, all controls, except the Power button, will be disabled.

To lock the controls

Touch the Child Lock button (). The timer indicator will display “Lo”.

To unlock the controls

- Ensure the cooktop is powered on.
- Press and hold the Child Lock button () for 3 seconds.
- You can now resume using your cooktop.

NOTE: While the cooktop is in lock mode, all controls, except the Power button, are disabled. In case of an emergency, you can always turn the cooktop off using the Power button. However, remember to unlock the cooktop before further operation.

The Auto-off Safety Feature

The cooktop includes a safety feature called auto-off safety. This activates when a cooking zone is left unintentionally on.

Default shutdown times are outlined in the table below:

Power Level	Default Operating Time
1	8
2	8
3	8
4	4
5	4
6	4
7	2
8	2
9	2

Operating Your Cooktop

Using the FlexZones

Only for model OCI903FTZ

- This function allows the FlexZone cooking areas to be used as a single large zone or as two independent zones, adapting to diverse cooking requirements.
- Comprised of two distinct inductors that can be controlled separately, activating only the area covered by the cookware for efficient heating.
- Proper centering of the cookware ensures accurate detection and even heat distribution.
- It is not recommended to use several zones outside of the FlexZones at the same time for a single pan.

Using the FlexZone as an single large zone:

- **Activate FlexZone Function:**
Press both Zone Selector buttons simultaneously to merge the bridge area into a single large zone.
- An alert will sound, indicating the cooktop has entered FlexZone selection, and the corresponding indicator will display flashing.
- Set the desired power level by touch and sliding the Power Level Adjustment Controls.

Cancel Flexible Zone Function

- Touch any of the Zone Selector buttons that are in use to deactivate the FlexZone function.
For example, if the left FlexZone is in use, press the front left Zone Selector button.
- The power settings will operate as usual for a standard cooking area.
- As Two Independent Zones:

Using the FlexZone as two independent zones

To utilise the FlexZone as two separate cooking zones with varying power settings:

- Touch the individual Zone Selector button for the cooking zone desired.
- Set the desired power level by touch and sliding the Power Level Adjustment Controls.

Using the Keep Warm function

Only for models OCI905TZ & OCI903FTZ

Activating the Keep Warm Function

- Touch the Zone Selector button next to the cooking zone featuring the Keep Warm function (front left cooking zone).
- Press the Keep Warm button and the zone indicator will display “|”.

Cancelling the Keep Warm Function

- Touch the Zone Selector button next to the cooking zone featuring the Keep Warm function (front left cooking zone).
- To cancel the Keep Warm function, touch and Slide Power Level Adjustment Controls to choose the desired power level. The cooking zone will return to the level you select.
- Alternatively, select another function control, such as Power Boost. The cooking zone will revert to your selection.

Using the Start / Pause function

Only for models OCI905TZ & OCI903FTZ

Activating Pause

Press the Start / Pause button. All heating zones will cease operation, displaying “||” on the zone indicators.

Deactivate Pause:

Touch any of the Zone Selector buttons first, followed by pressing the Start / Pause button again. All cooking zones will then return to their initial settings.

NOTE:

- The Start / Pause function is accessible when one or more cooking zones are active.
- For your safety, if the Start / Pause function isn't canceled within 30 minutes, the induction cooking will automatically switch off.

Cooking Guidelines

WARNING: Frying Caution

Be cautious when frying, especially with Boost mode, as oil and fats heat up rapidly. At extremely high temperatures, there's a risk of spontaneous ignition, posing a serious fire hazard.

Cooking Tips

- Reduce the power setting when food reaches boiling point.
- Use a lid to shorten cooking times and conserve energy by trapping heat.
- Minimise liquid or fat for quicker cooking.
- Initiate cooking at a high setting and lower it once the food is heated through.

Simmering and Rice Cooking

- Simmering, at around 85 °C, occurs below boiling, preserving flavours without overcooking. Ideal for soups, stews, egg-based, and flour-thickened sauces.
- Some tasks, like cooking rice, might require a higher setting than the lowest to ensure proper cooking within the recommended time.

Searing Steak

To cook juicy, flavourful steaks:

- Allow the meat to reach room temperature for 20 minutes before cooking.
- Preheat a heavy-based frying pan.
- Brush both sides of the steak with oil, then lower it into the hot pan with a drizzle of oil.
- Turn the steak once during cooking, judging doneness by firmness. Cooking times vary based on thickness.
- Rest the steak on a warm plate for a few minutes before serving to enhance tenderness.

Stir-Frying Steps

- Choose an induction compatible flat-based wok or a large frying pan.
- Prepare all ingredients and equipment beforehand for quick stir-frying. Cook in smaller batches for larger quantities.
- Briefly preheat the pan and add two tablespoons of oil.
- Cook any meat first, set it aside, and keep warm.
- Stir-fry vegetables until hot but still crisp, then reduce the heat, return the meat, and add the sauce.
- Gently stir to ensure even heating.
- Serve promptly.

Recommended Heat Settings

Power Level	Suitability
1-2	<ul style="list-style-type: none"> • Delicate warming for small amounts of food • Melting chocolate, butter, and foods that burn quickly • Gentle simmering • Slow warming
3-4	<ul style="list-style-type: none"> • Reheating • Rapid simmering • Cooking rice
5-6	<ul style="list-style-type: none"> • Pancakes
7-8	<ul style="list-style-type: none"> • Sauteing • Cooking pasta
9 + Power Boost	<ul style="list-style-type: none"> • Stir-frying • Searing • Bringing soup to the boil • Boiling water

Care & Maintenance

Care and Cleaning Guide

Marks, Blemishes or Spots	Solution	Warning
<p>Everyday soiling on glass (fingerprints, marks, stains left by food or non-sugary spillovers on the glass).</p>	<ol style="list-style-type: none"> 1. Switch the power to the cooktop off. 2. Apply a cooktop cleaner while the glass is still warm (but not hot!) 3. Rinse and wipe dry with a clean cloth or paper towel. 4. Switch the power to the cooktop back on. 	<ul style="list-style-type: none"> • When the power to the cooktop is switched off, there will be no 'hot surface' indication but the cooking zone may still be hot! Take extreme care. • Heavy-duty scourers, some nylon scourers and harsh/abrasive cleaning agents may scratch the glass. Always read the label to check if your cleaner or scourer is suitable. • Never leave cleaning residue on the cooktop as it may stain the glass.
<p>Boilovers, melts, and hot sugary spills on the cooktop glass.</p>	<ol style="list-style-type: none"> 1. Remove these immediately with a fish slice, palette knife or razor blade scraper suitable for ceramic glass cooktops, but beware of hot cooking zone surfaces: 2. Switch the power to the cooktop off at the wall. 3. Hold the blade or utensil at a 30° angle and scrape the soiling or spill to a cool area of the cooktop. 4. Clean the soiling or spill up with a dish cloth or paper towel. 5. Follow steps 2 to 4 for 'Everyday soiling on glass' above. 	<ul style="list-style-type: none"> • Remove stains left by melts and sugary food or spillovers as soon as possible. If left to cool on the glass, they may be difficult to remove or even permanently damage the glass surface. • WARNING: Cut hazard When the safety cover is retracted, the blade in a scraper is razor-sharp. Use with extreme care and always store safely and out of reach of children.
<p>Spillovers on the touch controls.</p>	<ol style="list-style-type: none"> 1. Switch the power to the cooktop off. 2. Soak up the spill 3. Wipe the touch control area with a clean damp sponge or cloth. 4. Wipe the area completely dry with a paper towel. 5. Switch the power to the cooktop back on. 	<p>The cooktop may beep and turn itself off, and the touch controls may not function while there is liquid on them. Make sure you wipe the touch control area dry before turning the cooktop back on.</p>

Troubleshooting

For Minor Faults

Problem	Possible Cause	Solution
The cooktop cannot be powered on.	No power is going to the cooktop.	Ensure the cooker is connected to the power, and is switched on.
		Check if there is a power outage in your home or area. If the problem persists contact our Support Team for guidance.
The touch controls won't respond, or are difficult to operate.	The controls may be locked	Deactivate the Child Lock function. See page 27.
	There may be a slight film of water on the controls.	Gently clean and dry the controls
	You may be using the tip of your finger as opposed to the pad when touching controls.	Make sure to use the pad of your finger rather than the tip.
The ceramic glass is being scratched.	Rough-edged cookware may have been used on the cooktop.	Use cookware with flat and smooth bases. See the section 'Choosing the right cookware' on page 19.
	Unsuitable cleaning products such as an abrasive scourer may have been used on the cooktop.	See Care & Maintenance on page 30.
Some of my cookware makes crackling or clicking noises.	This may be caused by the construction of your cookware (Layers of different metals vibrating differently).	This is normal for cookware and does not indicate a fault.
The induction cooktop makes a low humming noise when used on a high heat setting.	This is caused by the technology of induction cooking.	This is normal, but the noise should quieten down or disappear completely when you decrease the heat setting.
Fan noise coming from the cooktop.	A cooling fan built into your induction cooktop has come on to prevent the electronics from overheating. It may continue to run even after you've turned the cooktop off.	This is normal and needs no action. Do not switch the power to the induction cooktop off at the wall while the fan is running.

Troubleshooting

For Minor Faults

Problem	Possible Cause	Solution
Pans do not become hot and appears in the display.	The induction cooktop cannot detect the pan because it may not suitable for induction cooking.	Use cookware suitable for induction cooking. See the section 'Choosing the right cookware' on page 19.
	The induction cooktop cannot detect the pan because it is too small for the cooking zone or not properly centered on it.	Centre the pan and make sure that its base matches the size of the cooking zone.
The induction cooktop or a cooking zone has turned itself off unexpectedly, a tone sounds and an error code is displayed (typically alternating with one or two digits in the cooking timer display).	Technical fault.	Please note down the fault code, switch the power to the cooktop off at the wall, and contact our After Sales Support by calling 1300 11 4357 or by emailing support@residentiagroup.com.au.

Cooktop Fault Codes & Solutions

Fault Code	Possible Cause	Solution
E2 / E3	Abnormal supply voltage.	Switch the power to the cooktop off at the wall, and contact our After Sales Support by calling 1300 11 4357 or by emailing support@residentiagroup.com.au.
E4 / E5	Temperature sensor failure.	
E6 / E9	Bad induction cooktop heat radiation.	Please inspect whether power supply is normal. Power on after the power supply is normal.
E7 / E8	Temperature sensor of the IGBT failure.	Please restart after the induction cooktop cools down.

For Serious Faults

- Some minor faults can be fixed by referring to the table in this section, however if an emergency or serious fault occurs, immediately power off the cooktop and disconnect the power from the source.
- If a serious fault occurs, DO NOT attempt any repairs yourself, instead wait for a service agent to do so.
- For assistance or to organise an authorised service agent contact our After Sales Support by calling 1300 11 4357, or by emailing support@residentiagroup.com.au.
- NOTE:** If a service agent is asked to attend whilst the product is under warranty and finds that the problem is not the result of an appliance fault, then you may be liable for the cost of the call out charge.
- The appliance must be accessible for the service agent to perform any necessary repair. If your appliance is installed in such a way that a service agent is concerned that damage will be caused to the appliance or your kitchen, then they will not complete a repair.
- Please refer to the Warranty Information to learn more.

Purchase Details

Attach your receipt to this page

For future reference, please record the following information which can be found on the rating plate and the date of purchase which can be found on your sales invoice.

Store Details

Store Name

Address

Telephone

| Purchase Date

Product Details

Model No.

Serial No.

Warranty Information

WARRANTY TERMS AND CONDITIONS

INDUCTION COOKTOPS

This document sets out the terms and conditions of the product warranties for Residentia Group Appliances. It is an important document. Please keep it with your proof of purchase documents in a safe place for future reference should you require service for your Appliance.

1. In this warranty
 - (a) 'acceptable quality' as referred to in clause 10 of this warranty has the same meaning referred to in the ACL;
 - (b) 'ACL' means Trade Practices Amendment (Australian Consumer Law) Act (No.2) 2010;
 - (c) 'Appliance' means any Residentia Group product purchased by you accompanied by this document;
 - (d) 'ASR' means Residentia Group authorised service representative;
 - (e) 'Residentia Group' means Residentia Group Pty Ltd of 165 Barkly Ave, Burnley VIC 3121, ACN 70 600 546 656 in respect of Appliances purchased in Australia;
 - (f) 'major failure' as referred to in clause 10 of this warranty has the same meaning referred to in the ACL and includes a situation when an Appliance cannot be repaired or it is uneconomic for Residentia Group, at its discretion, to repair an Appliance during the Warranty Period;
 - (g) 'Warranty Period' means:
 - (i) where the Appliance is used for personal, domestic or household use (i.e. normal single family use) as set out in the instruction manual, the Appliance is warranted against manufacturing defects for 36 months, following the date of original purchase of the Appliance;
 - (h) 'you' means the purchaser of the Appliance not having purchased the Appliance for re-sale, and 'your' has a corresponding meaning.
2. This warranty only applies to Appliances purchased and used in Australia and is in addition to (and does not exclude, restrict, or modify in any way) any non-excludable statutory warranties in Australia.
3. During the Warranty Period Residentia Group or its ASR will, at no extra charge if your Appliance is readily accessible for service, without special equipment and subject to these terms and conditions, repair or replace any parts which it considers to be defective. Residentia Group or its ASR may use remanufactured parts to repair your Appliance. You agree that any replaced Appliances or parts become the property of Residentia Group. This warranty does not apply to light globes, batteries, seals, filters or similar perishable parts.
4. Parts and Appliances not supplied by Residentia Group are not covered by this warranty.

Warranty Information

5. You will bear the cost of transportation, travel and delivery of the Appliance to and from Residentia Group or its ASR. If you reside outside of the service area, you will bear the cost of:
 - (a) travel of an authorised representative;
 - (b) transportation and delivery of the Appliance to and from Residentia Group or its ASR, in all instances, unless the Appliance is transported by Residentia Group or its ASR, the Appliance is transported at the owner's cost and risk while in transit to and from Residentia Group or its ASR.
 6. Proof of purchase is required before you can make a claim under this warranty.
 7. You may not make a claim under this warranty unless the defect claimed is due to faulty or defective parts or workmanship. Residentia Group is not liable in the following situations (which are not exhaustive):
 - (a) the Appliance is damaged by:
 - (i) accident
 - (ii) misuse or abuse, including failure to properly maintain or service
 - (iii) normal wear and tear
 - (iv) power surges, electrical storm damage or incorrect power supply
 - (v) incomplete or improper installation
 - (vi) incorrect, improper or inappropriate operation
 - (vii) insect or vermin infestation
 - (viii) failure to comply with any additional instructions supplied with the Appliance;
 - (b) the Appliance is modified without authority from Residentia Group in writing;
 - (c) the Appliance's serial number or warranty seal has been removed or defaced;
 - (d) the Appliance was serviced or repaired by anyone other than Residentia Group, an authorised repairer or ASR.
 8. This warranty, the contract to which it relates and the relationship between you and Residentia Group are governed by the law applicable where the Appliance was purchased.
 9. To the extent permitted by law, Residentia Group excludes all warranties and liabilities (other than as contained in this document) including liability for any loss or damage whether direct or indirect arising from your purchase, use or non use of the Appliance.
 10. For Appliances and services provided by Residentia Group in Australia, the Appliances come with a guarantee by Residentia Group that cannot be excluded under the Australian Consumer Law. You are entitled to a replacement or refund for a major failure and for compensation for any other reasonably foreseeable loss or damage. You are also entitled to have the Appliance repaired or replaced if the Appliance fails to be of acceptable quality and the failure does not amount to a major failure. The benefits to you given by this warranty are in addition to your other rights and remedies under a law in relation to the Appliances or services to which the warranty relates.
 11. At all times during the Warranty Period, Residentia Group shall, at its discretion, determine whether repair, replacement or refund will apply if an Appliance has a valid warranty claim applicable to it.
 12. Missing parts are not covered by warranty. Residentia Group reserves the right to assess each request for missing parts in a case by case basis. Any parts that are not reported missing in the first week after purchase will not provide free of charge.
 13. To enquire about claiming under this warranty, please follow these steps:
 - (a) carefully check the operating instructions, user manual and the terms of this warranty;
 - (b) have the model and serial number of the Appliance available;
 - (c) have the proof of purchase (e.g. an invoice) available;
 - (d) telephone the numbers shown below.
 14. You accept that if you make a warranty claim, Residentia Group and its ASR may exchange information in relation to you, in order to enable Residentia Group to meet its obligations under this warranty.
-
- IMPORTANT**
Before calling for service, please ensure the steps in point 13 have been followed.
- CONTACT SERVICE**
1300 11 HELP (4357)
support@residentiagroup.com.au

The Australian Consumer Law requires the inclusion of the following statement with this warranty:

Our goods come with guarantees that cannot be excluded under the Australian Consumer Law. You are entitled to a replacement or refund for a major failure and for compensation for any other reasonably foreseeable loss or damage. You are also entitled to have the goods repaired or replaced if the goods fail to be of acceptable quality and the failure does not amount to a major failure.



EST. 1981

Designed to Enhance

omega

Omega is proudly owned in Australia
by Residentia Group Pty. Ltd.

@residentia.group
www.residentia.group