

DGC 7460 HC Pro GRGR
Combination steam oven
for steam cooking, baking, roasting with networking + BrilliantLight.



EAN: 4002516630180 / Material number: 12087470

- 3-in-1 appliance - oven, steam and combination cooking
- Fast and even steam distribution with DualSteam technology to seal in more nutrients and vitamins
- Perfect baking and roasting results with combination cooking using dry and moist heat
- Motorised lift-up control panel with SoftClose to access water and condensate container
- Easy thorough cleaning with HydroClean, an automatic self clean function allowing for food residue to be removed with ease leaving the cavity spotlessly clean.

| Construction type and design | |
|---|---------------|
| Steam combination oven | • |
| VitroLine | • |
| Appliance Colour | Graphite Grey |
| Convenience features | |
| Rapid heat-up | • |
| Pre-heating | • |
| External steam generation | • |
| Oxygen sensor | • |
| Individual humidity settings in combination cooking | • |
| Menu cooking without transfer of taste | • |
| Prepare plated meals with "Mix & Match" | • |
| Keeping warm | • |
| Crisp function | • |
| Operating modes | |
| Defrost | • |
| Automatic programmes | • |
| Combination cooking | • |
| Combination cooking with Fan plus | • |
| Combination cooking with Conventional heat | • |
| Combination cooking with grill | • |
| Steam cooking | • |
| Sous-vide | • |
| Reheat | • |
| Roast with moisture | • |
| Grill operating modes | • |
| Grill | • |
| Economy grill | • |
| Fan plus | • |
| Intensive bake | • |
| Cake plus | • |
| Conventional heat | • |
| Top heat | • |
| Bottom heat | • |
| Fan grill | • |
| Eco fan heat | • |
| Eco steam cooking | • |
| Plate warming | • |
| Special applications | • |
| User convenience | |
| Networking with Miele@home | • |
| Display | DirectSensor |
| SoftOpen | • |
| SoftClose | • |
| MultiLingua | • |
| Motorised lift-up control panel with SoftClose | • |
| Quantity-independent cooking | • |
| Steam cooking on up to 4 levels at the same time | • |
| Automatic menu cooking | • |
| Steam reduction before end of programme | • |
| Time of day display | • |

DGC 7460 HC Pro GRGR
Combination steam oven
for steam cooking, baking, roasting with networking + BrilliantLight.



- 3-in-1 appliance - oven, steam and combination cooking
- Fast and even steam distribution with DualSteam technology to seal in more nutrients and vitamins
- Perfect baking and roasting results with combination cooking using dry and moist heat
- Motorised lift-up control panel with SoftClose to access water and condensate container
- Easy thorough cleaning with HydroClean, an automatic self clean function allowing for food residue to be removed with ease leaving the cavity spotlessly clean.

EAN: 4002516630180 / Material number: 12087470

| | |
|--|-----|
| Date display | • |
| Minute minder | • |
| Programmable start of cooking duration | • |
| Programmable end of cooking duration | • |
| Programmable cooking duration | • |
| Actual temperature display | • |
| Target temperature display | • |
| Buzzer when desired temperature is reached | • |
| Recommended temperature | • |
| User programmes | • |
| Sabbath programme | • |
| Individual settings | • |
| Efficiency and sustainability | |
| Power rating in off mode in W | 0.5 |
| Power rating in standby mode in W | 1.0 |
| Power rating in networked standby in W | 2.0 |
| Time until automatic switch to standby in min | 20 |
| Time until automatic switch to networked standby in min | 20 |
| Time until automatic switch to off mode in min | 20 |
| Cleaning convenience | |
| Stainless-steel oven interior with linen structure | • |
| Hinged grill element | • |
| External steam generator | • |
| HydroClean | • |
| Maintenance programmes | • |
| Soak programme | • |
| Rinse programme | • |
| Oven compartment drying programme | • |
| Quick-release side racks | • |
| Removable stainless-steel side racks | • |
| Automatic descaling | • |
| CleanGlass door | • |
| Steam technology and Water supply | |
| DualSteam | • |
| Steam generator power in kW | 3.3 |
| Fresh water container volume in l | 1.4 |
| Fresh water container behind motorised control panel | • |
| Condensate container behind motorised lift-up control panel with SoftClose | • |
| Drain filter | • |
| Safety | |
| Appliance cooling system and touch-cool front | • |
| Safety switch-off | • |
| System lock | • |
| Vapour cooling system | • |
| Sensor lock | • |
| Technical data | |
| Oven compartment volume in l | 68 |

DGC 7460 HC Pro GRGR
Combination steam oven
for steam cooking, baking, roasting with networking + BrilliantLight.



EAN: 4002516630180 / Material number: 12087470

- 3-in-1 appliance - oven, steam and combination cooking
- Fast and even steam distribution with DualSteam technology to seal in more nutrients and vitamins
- Perfect baking and roasting results with combination cooking using dry and moist heat
- Motorised lift-up control panel with SoftClose to access water and condensate container
- Easy thorough cleaning with HydroClean, an automatic self clean function allowing for food residue to be removed with ease leaving the cavity spotlessly clean.

| | |
|---|-----------------|
| No. of shelf levels | 4 |
| Appliance dimensions (W x H x D) in mm | 595 x 595 x 573 |
| Numbered shelf levels | • |
| Door hinge | Bottom |
| Oven light | BrilliantLight |
| Oven temperature regulation min. in °C | 30 |
| Oven temperature regulation max. in °C | 230 |
| Electronic steam oven temperature regulation min. in °C | 40 |
| Electronic steam oven temperature regulation max. in °C | 100 |
| Niche width min. in mm | 560 |
| Niche width max. in mm | 568 |
| Niche height min. in mm | 590 |
| Niche height max. in mm | 595 |
| Niche depth in mm | 550 |
| Appliance width in mm | 595 |
| Appliance height in mm | 595 |
| Appliance depth in mm | 573 |
| Weight in kg | 46.4 |
| Total rated load in kW | 3.45 |
| Voltage in V | 230 |
| Frequency in Hz | 50 |
| Number of phases | 1 |
| Fuse rating in A | 16 |
| Mains cable with plug | • |
| Length of supply lead in m | 2 |
| Accessories supplied | |
| Universal tray with PerfectClean | 1 |
| Baking and roasting rack with PerfectClean | 1 |
| Removable side runners (pair) | 1 |
| No. of perforated stainless-steel cooking container | 1 |
| No. of solid stainless-steel cooking containers | 1 |
| HydroClean cleaning agent | 1 |
| Descaling tablets | 2 |

DGC 7460 HC Pro BRSW Installation diagrams.

Installation in a tall unit

The furniture housing unit must not have a back panel fitted behind the building-in niche.

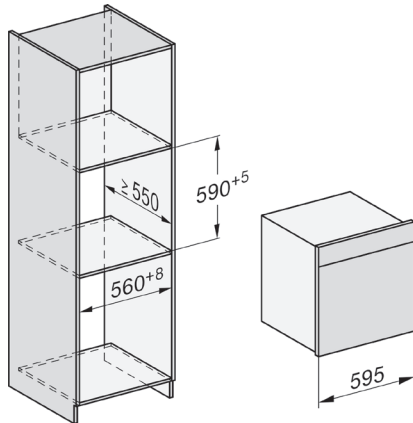

Installation in a base unit

When building the combi steam oven into a base unit underneath a cooktop, please also observe the installation instructions for the cooktop as well as the building-in height required for the cooktop.

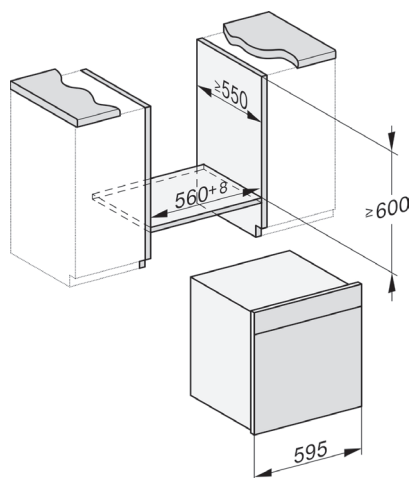

Side View

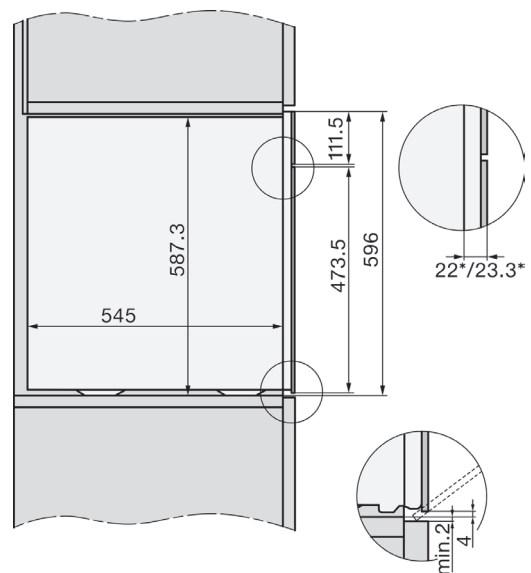

All dimensions are given in mm