

Designed to Enhance

EST. 1981

omega

Installation + User Manual

OIFRU304

Integrated Upright Refrigerator 304L

Contents

03	Welcome
04	Safety Information
08	Your Refrigerator
10	Installing Your Refrigerator
24	Operating Instructions
26	Food Storage Advice
27	Cleaning & Maintenance
29	Troubleshooting
31	Purchase Details
32	Warranty Information

Welcome

Residentia Group

Office 165 Barkly Avenue Burnley
Victoria Australia 3121

ACN 70 600 546 656

Online residentia.group
omegaappliances.com.au

Post PO BOX 5177 Burnley
Victoria Australia 3121

Phone 1300 11 4357

Email support@residentia.group

Congratulations on purchasing your new Refrigerator!

Omega appliances are proudly owned, distributed, designed and engineered in Australia by Residentia Group Pty Ltd.

Please refer to the warranty chapter at the rear of this manual for information regarding your product's parts and labour warranty, or visit us online at:

→ www.residentiagroup.com.au

Here at Residentia Group, we are customer obsessed and our Support Team are there to ensure you get the most out of your appliance. Should you want to learn more about your unit, and importantly, taking care of the appliance, our Support Team are here to help. You can use our online Support Centre at any time by visiting:

→ www.support.residentiagroup.com.au

Or you can contact us by dialling: 1300 11 HELP (4357)

It is important that you read through the following user manual thoroughly, in order to familiarise yourself with the installation and operation requirements of your appliance, and to ensure optimum performance.

Again, thank you for choosing an Omega appliance and we look forward to being of service to you.

Kind Regards,

The Residentia Team

Customer Care

At Residentia Group, we strongly encourage the use of authentic spare parts to guarantee the best results. When contacting our spare parts team through 1300 11 HELP, or by emailing parts@residentiagroup.com.au, please ensure that you have the model and serial numbers on hand, which are found on your appliances' rating plate.

Safety Information

Important Safety Instructions

Read Carefully and Keep for Future Reference

Read this manual thoroughly before first use, even if you are familiar with this type of product. The safety precautions enclosed herein reduce the risk of fire, electric shock and injury when correctly adhered to. Make sure you understand all instructions and warnings.

Keep the manual in a safe place for future reference, along with the completed warranty card and purchase receipt. If you sell or transfer ownership of this product, pass on these instructions to the new owner.

Always follow basic safety precautions and accident prevention measures when using an electrical appliance. The following statements you will see in this booklet have these meanings:

WARNING: Indicating important information concerning your personal safety.

CAUTION: Indicating information on how to avoid damaging the appliance or cabinetry.

IMPORTANT: Indicating tips and information about use of the appliance.

Usage Conditions and Restrictions

- **Domestic use only:** This appliance is intended for indoor household use only. It is not intended for commercial, industrial or outdoor use. It is not intended for use in a recreational vehicle.
- **Purpose:** Do not use this appliance for anything other than its intended purpose. Other uses are not recommended and may cause fire, electric shock or personal injury.
- **Attachments:** The use of attachments is not recommended by the appliance manufacturer and distributor as they may be hazardous.
- **Improper use:** Damage due to improper use, or repairs made by unqualified personnel will void your warranty. We assume no liability for any eventual damages caused by misuse of the product or non-compliance with these instructions.

Before Using Your Appliance

This manual explains the proper use of your Omega Refrigerator. Please read this manual carefully before using the product. This manual should be kept in a safe place for handy reference.

This Refrigerator is a domestic appliance which has been manufactured and tested to comply with Australian and New Zealand Standards.

This Refrigerator must only be installed in accordance with the instructions provided. Incorrect installation may cause harm to persons, damage property and void the product's warranty.

Read the following carefully to avoid damage or injury.

IMPORTANT: Check for any damage or marks. If you find the appliance is damaged or marked, you must report it within 7 days if you wish to claim for damage/ marks under the manufacturer's warranty. This does not affect your statutory rights.

Safety Instructions

- Before the installation and use of the appliance, carefully read the supplied instructions.
- The manufacturer is not responsible if an incorrect installation and use causes injuries and damages.
- Always keep the instructions with your appliance for future reference.
- If you will not use the appliance for a long time, it is advised to turn the plug off.
- You must wear gloves and eye protectors when installing the product.
- You must also take measures against high noise levels when drilling the floor or using a drill.

WARNING: To prevent any damages to your and others' life or property, you have to follow these safety instructions.

WARNING: When positioning the appliance, ensure the supply cord is not trapped or damaged.

WARNING: Do not locate multiple portable socket-outlets or portable power supplies at the rear of the appliance.

Safety Information (Continued)

Children & Vulnerable People Safety

WARNING: Risk of suffocation, injury or permanent disability.

This appliance is not intended for use by persons (including children) with reduced physical, sensory or mental capabilities, or lack of experience and knowledge, unless they have been given supervision or instruction concerning use of the appliance by a person responsible for their safety.

Children should be supervised to ensure that they do not play with the appliance.

- Children should be supervised to ensure that they do not play with the appliance.
- Keep all packaging away from children.

Unpacking

- During transportation, protective packaging was used to protect the appliance against any damage. After unpacking, please dispose of all elements of packaging in a way that will not cause damage to the environment.
- Some materials used for packaging the appliance are environmentally friendly; they are 100% recyclable and are marked with the appropriate symbol.
- Remove all the packaging.

CAUTION: During unpacking, the packaging materials (polythene bags, polystyrene pieces, etc.) should be kept out of reach of children.

- Always move the appliance cautiously. Do not use the machine door or the handle to lift the appliance.

WARNING: Do not damage the refrigerant circuit.

WARNING: If you suspect refrigerant leakage, avoid touching the unit or power outlet. Ventilate the room and, if possible, turn off the unit using the circuit breaker. Contact the manufacturer immediately. Refrigerant can cause serious injury upon contact with skin or eyes; seek medical treatment promptly if exposed.

- Do not install or use a damaged appliance.
- Before installation or cleaning, disconnect the refrigerator from the power source and reset temperature controls. Reconnect and reset after completing tasks.
- Please contact 1300 11 HELP (4357) to arrange an authorised technician if you need assistance with installing the appliance.

Electrical Connection

CAUTION: Risk of fire and electrical shock!

- Ensure the appliance's plug is easily accessible.
- Ensure proper grounding of the appliance before operation. The appliance must be earthed.

WARNING: If you are unsure about grounding instructions, consult a qualified electrician or service person. Wait at least 5 minutes before reconnecting the power cord to prevent appliance failure.

- Make sure that the electrical information on the rating plate agrees with the power supply. If not, contact an electrician.
- Always use a correctly installed shockproof socket.
- Do not use any multi-plug adapters or extension cables.

WARNING: Incorrect grounding may lead to breakdowns or electric shocks. Use a dedicated outlet; using multiple devices on one outlet may cause fire hazards. Avoid positioning the power plug upwards or in a squeezed space at the back of the fridge to prevent water damage or fire risk.

- Ensure the supply cord is not trapped or damaged during positioning.
- Connect the mains plug to the mains socket only at the end of the installation. Make sure that there is access to the mains plug after the installation. Do not connect the appliance plug with a power connection board.
- Do not pull the mains cable to disconnect the appliance. Always pull the mains plug.
- Do not touch the mains cable or the mains plug with wet hands.

WARNING: If the supply cord is damaged, it must be replaced by the manufacturer or its service agent or similarly qualified person in order to avoid a hazard.

WARNING: All electrical work must be done in accordance with local and national electrical codes as applicable and should be undertaken by licenced and qualified persons only. Failure to follow these instructions can result in death, fire or electrical shock.

This product operates on 220-240V/50Hz only. The allowable voltage fluctuation range is 187V ~ 242V. It cannot be used with frequencies other than 50Hz.

To ensure safety, the socket and its cable must be capable of withstanding a current of above 10A.

Safety Information (Continued)

Appliance Placement

- Use this appliance in a domestic household only.
- Avoid installing it in wet or high humidity environments to prevent deterioration and electrical hazards.
- Install the appliance in a dry, well-ventilated room close to a wall outlet for easy access to power supply in case of accidents.
- Avoid exposing the unit to extreme heat or open flame, and ensure adequate airflow around the unit to prevent electric shock or injury.
- Do not cover or obstruct the exhaust area on the back of the unit to avoid electric shock or injury.

Care & Cleaning

CAUTION: Risk of injury or damage to the Refrigerator.

- Before installation or cleaning, disconnect the refrigerator from the power source and reset temperature controls. Reconnect and reset after completing tasks.
- Unplug the power cord when cleaning or handling the interior lamp to prevent electric shock or injury. Use a dry, clean cloth to remove water or dust from the power plug; do not touch it with wet hands. Ensure the power cord is not bent or pressed by heavy objects to avoid damage.
- Do not use a steam cleaner on the appliance.
- Avoid spraying water inside or outside the fridge or cleaning it with benzene or thinner.
- Use caution with cleaning agents; acidic cleaners, abrasive brushes, sharp tools, or those containing benzene should not be used.
- Clean the appliance with a moist soft cloth. Only use neutral detergents. Do not use abrasive products, abrasive cleaning pads, solvents or metal objects.

WARNING: Do not use mechanical devices or other means to accelerate the defrosting process, other than those recommended by the manufacturer.

Appliance Use

WARNING: Risk of fire, explosion, electric shock or damage to the appliance.

WARNING: Keep ventilation openings, in the appliance enclosure or in the built-in structure, clear of obstruction.

- Do not change the specification of this appliance.
- Do not store explosive substances such as aerosol cans with a flammable propellant in this appliance.
- Please do not close the appliance door with excessive force
- Follow instructions to prevent food contamination, including proper storage and cleaning practices.
- This appliance is designed to be used in ambient temperatures between 10 and 32°C. Use outside of this range may cause the appliance to fail.

WARNING: Do not use electrical appliances inside the food storage compartments of the appliance, unless they are of the type recommended by the manufacturer.

- Only use glassware designed for refrigeration use to prevent breakage and injury. Do not place ice in thin crystal cups or ceramic ware to avoid breakage and injury.
- Avoid placing heavy or dangerous objects inside the fridge, as they may cause injury, fire, or electric shock.
- Do not touch food or containers in the fridge with wet hands to prevent frostbite.
- Do not use a dryer or light a candle inside the unit, as it may cause explosion or fire.
- Avoid clinging to the door or trays, especially for children, to prevent the fridge from falling and causing serious injuries or death.



The refrigerant (R600a) is flammable.

Symbol ISO 7010 W021

WARNING: Risk of fire/flammable materials!

Safety Information (Continued)

Disposal of the Appliance

- Disconnect the appliance from the mains supply, cut off the mains cable and discard it.
- Remove the doors and secure shelves before discarding old refrigerators or freezers to prevent injury or children and pet entrapment.
- When discarding the unit, keep it away from extreme heat sources due to flammable refrigerant and foaming agent.
- Adhere to local laws and regulations when discarding the refrigerator.
- Old appliances should not simply be disposed of with normal household waste and should be delivered to a collection and recycling centre for electric and electronic equipment. A symbol shown on the product, the instruction manual or the packaging shows that it is suitable for recycling.

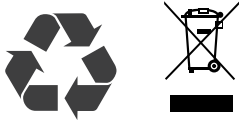

- Dispose of refrigerant and insulation blowing gas at authorised waste disposal centers. Avoid exposing them to extreme heat or open flames.
- The packaging is designed to protect the appliance from damage during transportation. The packaging materials are environmentally friendly and should be recycled. Recycling the packaging can reduce the use of raw materials in the manufacturing process and the amount of waste in landfill sites
- Packaging materials of the product are manufactured from recyclable materials in accordance with our National Environment Regulations. Do not dispose of the packaging materials together with the domestic or other wastes. Take them to the packaging material collection points designated by the local authorities.
- Materials used inside the appliance are recyclable and are labelled with information concerning this. By recycling materials or other parts from used devices you are making a significant contribution to the protection of our environment.
- Information on appropriate disposal centres for used devices can be provided by your local authority.

Unpacking

- During transportation, protective packaging was used to protect the appliance against any damage. After unpacking, please dispose of all elements of packaging in a way that will not cause damage to the environment.
- Remove the packaging box and take off the top foam.

IMPORTANT: The bottom air inlet/outlet hood will be located within the top foam.

- Remove the protective foam from the sides and inside the refrigerator.
- Lift the refrigerator with assistance to remove the foam pad underneath.
- Open the refrigerator door and take out the installation accessories and other items stored inside.
- All materials used for packaging the appliance are environmentally friendly; they are 100% recyclable and are marked with the appropriate symbol.

CAUTION: During unpacking, the packaging materials (polythene bags, polystyrene pieces, etc.) should be kept out of reach of children.

Declaration of Compliance

When you have unpacked the appliance, make sure that it has not been damaged in any way. If you have any doubts at all, do not use it: contact a professionally qualified person. Keep packing materials such as plastic bags, polystyrene, or nails out of the reach of children because these are dangerous to children.

Your Refrigerator

Components, Parts and Accessories

Your Refrigerator comes with the following accessories:

A. Control Panel

B. Glass Shelves (×6)

C. Mobile Box Drawer (×1)

D. Steel Wire Wine Rack (×1)

E. Crisper Drawers (×2)

F. Door Trays (×5)

G. LED Lighting

* Egg Trays (×2)

* User Manual (×1)

* Quick Start Guide (×1)

Model: **OIFRU304**

* Not pictured but also included



Note: The diagrams and images in this user manual are for explanatory purposes only. Your appliance's configuration may be different.

Your Refrigerator (Continued)

Product Dimensions

The dimensional diagrams for this refrigerator provide essential information about its size and layout. These diagrams detail the fridge's measurements enabling you to plan its placement effectively.

Note: The diagrams and images in this user manual are for explanatory purposes only. Your appliance's configuration may be different.

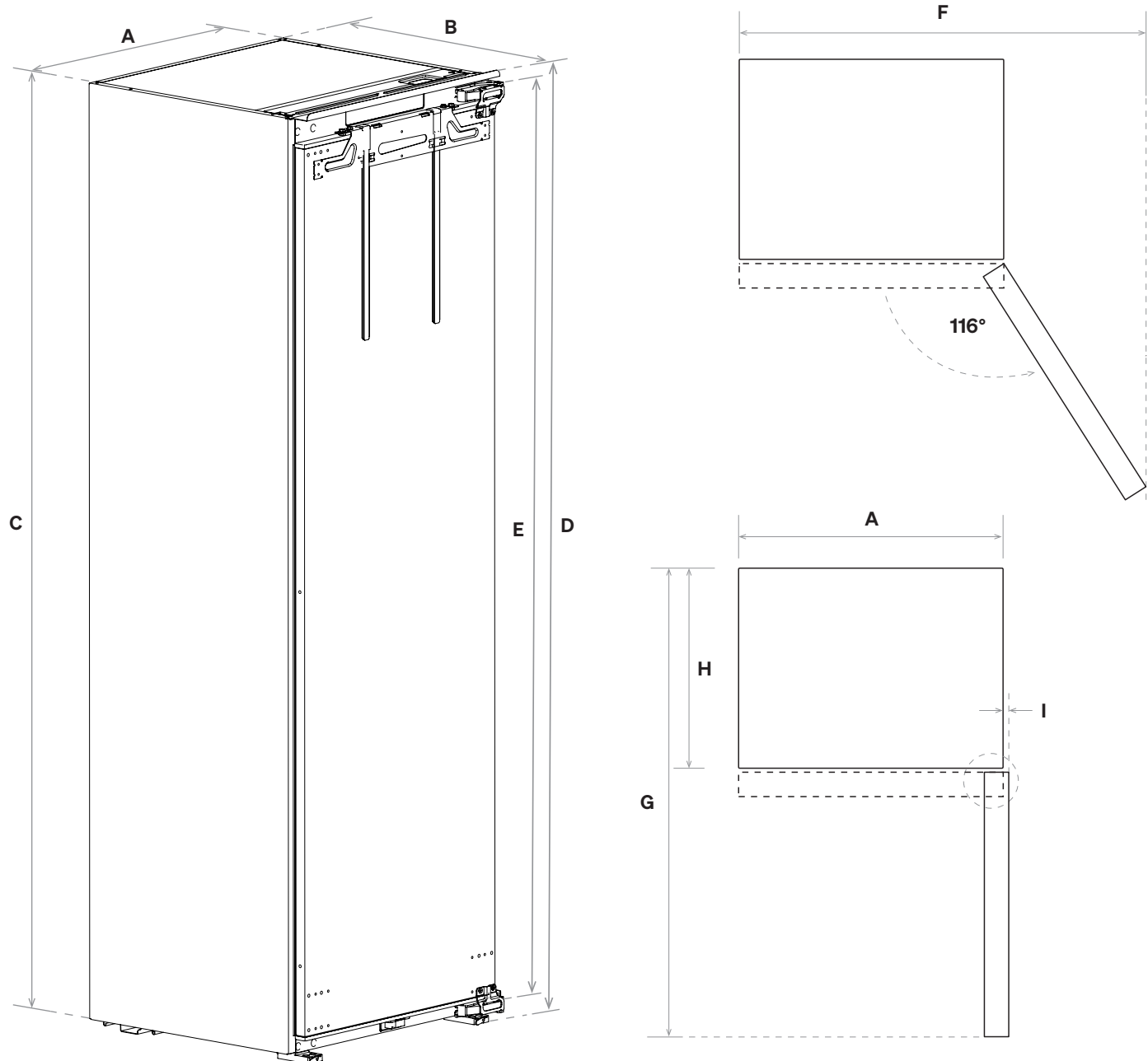

Dimensions (mm)

A 557

D 1785

G 1118

B 550

E 1736

H 515

C 1770

F 750

I 8

Installing Your Refrigerator

Preparing the Cabinetry

In order to ensure that the built-in appliance functions properly, the cabinet containing it must be appropriate. The diagram below gives the dimensions of the cut-out for installation and required clearances.

Minimum Ventilation Clearances

- An air intake should be provided through a plinth vent underneath the refrigerator in the cabinet run to allow free air in.
- A cabinetry cutout should be made according to the diagram.
- If no free airflow is available into the room, a plinth vent or another form of ventilation must be installed.

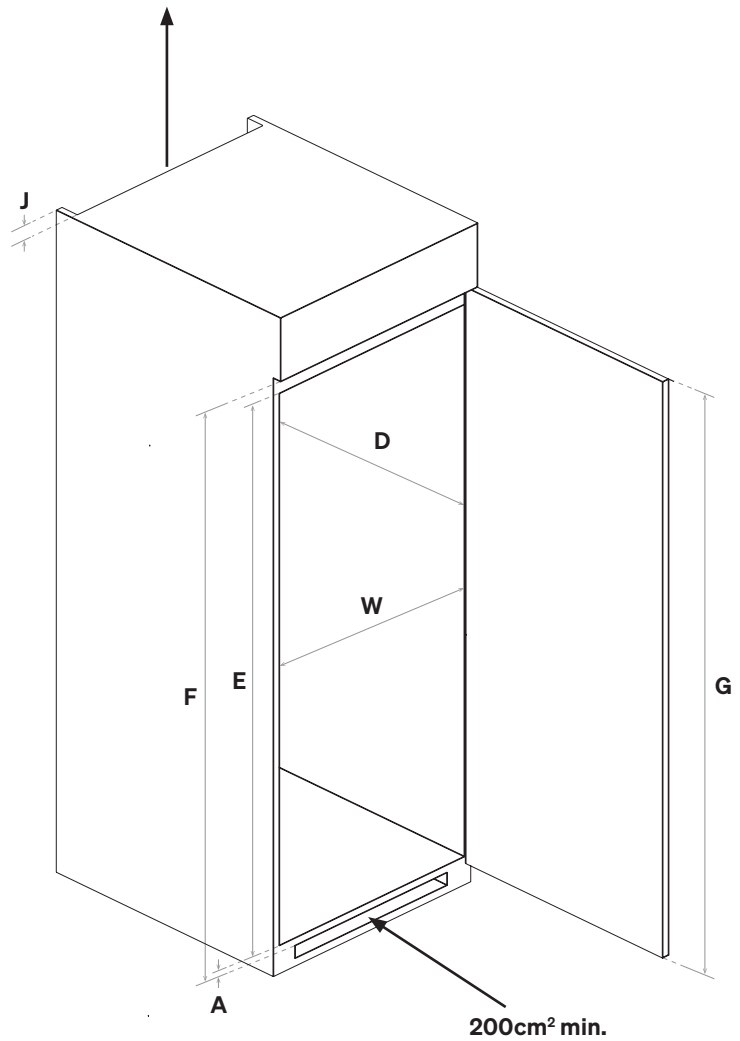
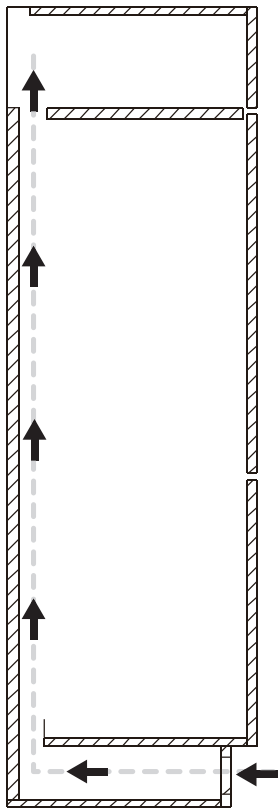

Cavity dimensions (mm)

A = Door Panel Thickness

E 1773 – 1780

J 50 min.

W 564 – 570

F G + 4

D 560 min.

G 1785 + A min.

Installing Your Refrigerator (Continued)

Transportation

- Avoid transporting the refrigerator horizontally or laying it down. Keep it upright during transportation to prevent damage.
- When moving the refrigerator, refrain from holding onto the door or handle. Always lift the refrigerator from the bottom to ensure safe handling.
- Never attempt to move the unit alone. It is essential to have at least two people to safely lift or move the refrigerator. This precaution helps prevent injury and ensures the unit remains intact during transportation.
- **CAUTION:** You must allow the fridge to settle for at least 24 hours prior to switching the power on.

Positioning Your Refrigerator

- The refrigerator should be positioned on a solid, level surface to ensure the appliance operates efficiently and doesn't wobble.
- Keep the refrigerator away from damp areas where water is present. Promptly remove any water or dirt from the surfaces using a soft cloth to prevent rust and maintain optimal efficiency.
- Keep the fridge away from heat sources like stoves, ovens, and direct sunlight. Heat can affect the fridge's performance and energy consumption.
- Kitchen floor and the bottom of the product must be at the same level. Otherwise, problems may occur with the air ventilation of the product.
- The cooling system at the rear of the appliance must not touch the rear wall. A larger gap will improve the cooling efficiency.
- The appliance must be installed with adequate ventilation. Ensure that there is clearance above the appliance to allow air to escape and that there is space between the rear of the appliance and the wall.

Installation of Power Supply

Please follow these guidelines for safe installation and use:

- Ensure that the power socket or fuse is easily accessible in case of emergency; it must not be positioned behind the appliance.
- Avoid contact between the plug or cable and the back surface of the appliance to prevent damage from vibrations.
- Do not plug other appliances into outlets located behind this product.
- In high-humidity areas, corrosion may develop on the appliance's outer surface. Keep the installation area dry and clean to prevent this.

IMPORTANT: To Prevent Electric Shock!

- Connect the plug to a grounded 3-pin socket.
- Do not remove the grounding pin from the plug.
- Avoid using adapters or extension cords.

IMPORTANT:

- Failure to adhere to these instructions can result in serious injury, death, fire, or electric shock. Incorrect grounding of the appliance may lead to electric shock. If there is any doubt regarding the grounding of the appliance, have it checked by a qualified electrician.
- Installation, repairs, and other servicing must only be performed by qualified individuals. Ensure that the voltage, load, and circuit current ratings listed on the appliance's data plate match your household power supply before installation.

Installing Your Refrigerator (Continued)

Cabinet Inspection

- Ensure the cabinet dimensions and door panel match the specifications (refer to the dimension drawing on page 10).
- Verify the position and routing of the power cable.
- Check that the power socket has a normal power supply. The socket should be located outside the refrigerator cabinet and near the cabinet opening for easy access.
- Ensure the ground is level using a bubble level tool.
- There must be no objects preventing the installation of the product at the back and on the side walls of the product's installation place.
- Check the uprightness of the cabinetry flanges with a bubble level tool. Improper levelling may cause installation issues.

NOTE: Make sure all the above requirements are met before proceeding to the installation.

- Ensure that the cabinetry where the appliance will be installed is securely mounted in your kitchen. The cabinetry must be properly anchored to both the floor and the wall using appropriate connections.
- For optimal installation, the clearances between the cabinetry and the appliance should adhere to the values outlined in the installation instructions.

Ventilation

Vent holes where the air enters and exits the unit must not be blocked or obstructed. In addition, you must periodically clean the dust and dirt that accumulate on these holes in time.

Electrical Connection

- Never use an extension cable.
- The power socket must be grounded and checked by an authorised technician.
- Ensure the electrical wiring location complies with the dimensions specified in the manual.
- Wiring location must be within the specified range.

IMPORTANT: Risk of Electric Shock!

- Electrical grounding is required. The appliance is equipped with a three-pin plug to protect against electric shocks.
- Do not remove the grounding terminal from the plug.
- Do not use two-pin adapters or extension cables.

WARNING:

- Do not connect the grounding cable to a gas pipe. If uncertain about proper grounding, consult a qualified electrician.
- Do not install a fuse on the neutral or grounding circuit.
- **WARNING:** Wait 24 hours before powering on the appliance to allow the refrigerant and lubricants to stabilise.

Climate Classes

The information about the climate range of the appliance is provided on the rating plate. It indicates at which ambient temperature (that is room temperature in which the appliance is working) is optimal for the operation of the appliance.

- **Extended temperature (SN):**
This refrigerating appliance is intended to be used at ambient temperatures ranging from 10°C to 32°C.
- **Temperate (N):**
This refrigerating appliance is intended to be used at ambient temperatures ranging from 16°C to 32°C.
- **Subtropical (ST):**
This refrigerating appliance is intended to be used at ambient temperatures ranging from 16°C to 38°C.
- **Tropical (T):**
This refrigerating appliance is intended to be used at ambient temperatures ranging from 16°C to 43°C.

Installing Your Refrigerator (Continued)

Installation Accessories

The following installation accessories are supplied with your Refrigerator:

A. Door Opening Side Brackets (×2)

B. Door Opening Side Bracket Covers (×2)

C. Hinge Side Brackets (×2)

D. Hinge Side Bracket Decorative Covers (×2)

E. Top Baffle Covers (×2)

F. Sealing Strip (×1)

G. Top of Door Decorative Cover (×1)

H. Bottom Support Covers (×4)

I. Hinge Decorative Covers (×4)

J. ST4.2×13, Phillips Pan Head Self-Tapping Screw (×14)

K. ST4.2×19, Phillips Pan Head Self-Tapping Screw (×4)

L. ST3.9×16, Phillips Countersunk Self-Tapping Screw (×4)

M. ST2.9×11, Phillips Countersunk Self-Tapping Screw (×8)

A

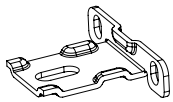

B

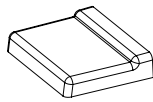

C

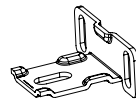

D

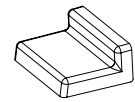

E

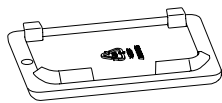

F

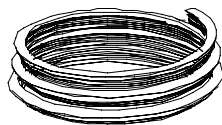

G



H



I



J



K



L



M



Installing Your Refrigerator (Continued)

Reversing the Door Swing

If you need to change the direction your fridge doors open, there are a few practical and functional considerations to keep in mind.

- Consider the layout of your kitchen, including traffic flow and where the fridge will be placed. Ensure that the door opens in a way that doesn't block other appliances or walking paths.
- Make sure the doors open in a way that provides easy access to the fridge's contents. Consider which side will be more convenient for everyday use.
- Ensure there is enough space for the doors to fully open without hitting walls or other cabinets.

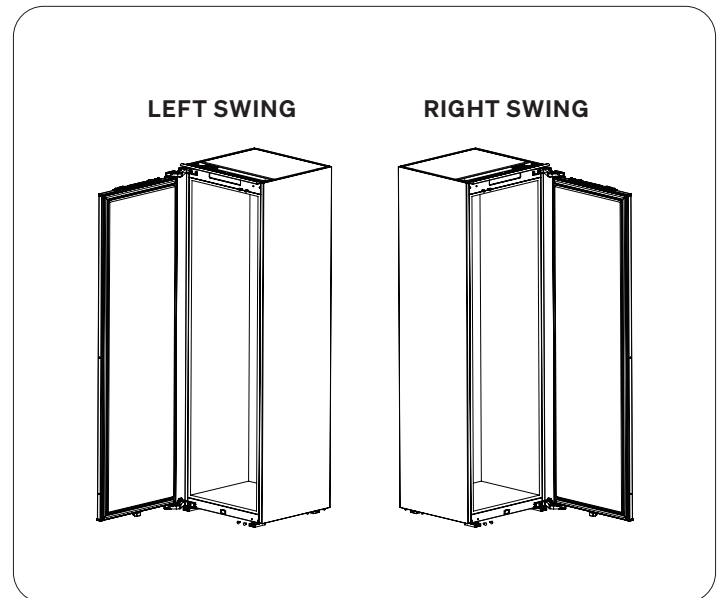

Door Reversal Procedure

CAUTION: We recommend to have at least two people whilst performing this procedure.

1. Open the fridge door and take out the Insert Pins of the Upper and Lower Beam assemblies.
2. Remove the hinge screws, then carefully lift the door off, as it is heavy.

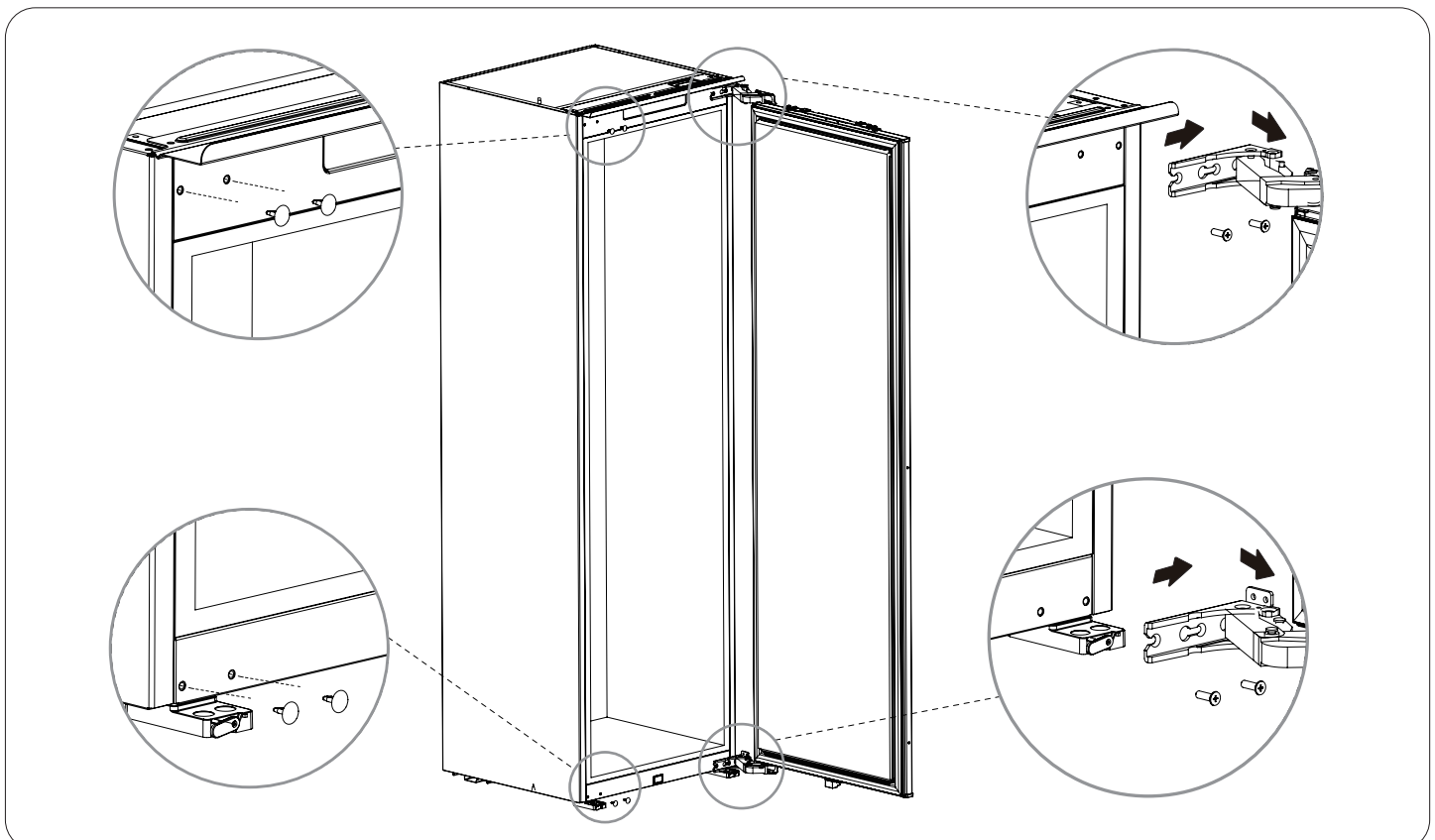

Installing Your Refrigerator (Continued)

3. Remove the Upper and Lower Hinges from the doors, then attach the Hinges to the opposite side of each door.

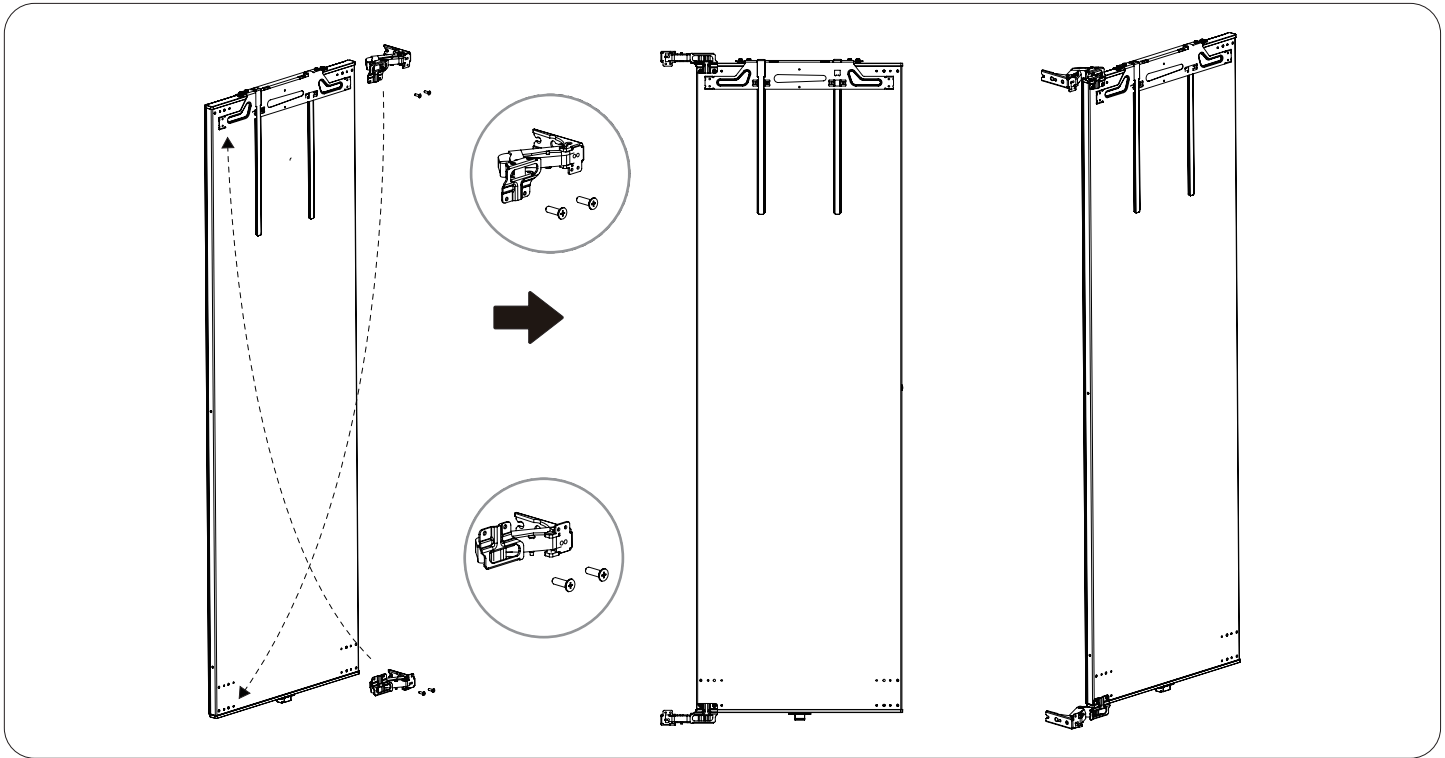

4. Reinstall the door onto the cabinet and secure it with screws. Insert the Hinge Pin Covers into the screw holes on the opposite side. The door reversal is now complete.

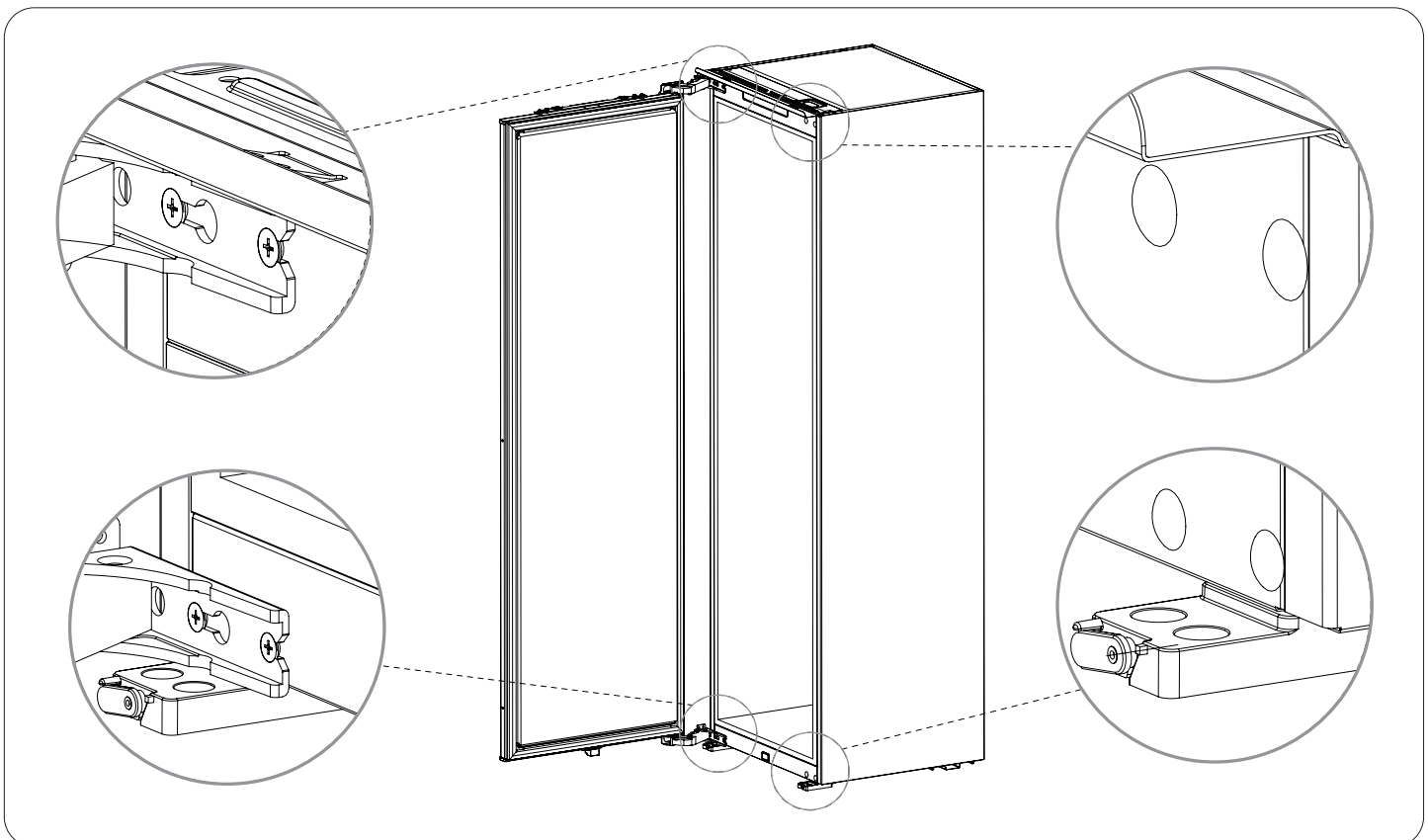

Installing Your Refrigerator (Continued)

Unpacking

- During transportation, protective packaging was used to protect the appliance against any damage. After unpacking, please dispose of all elements of packaging in a way that will not cause damage to the environment.
- At least two people are required to safely carry the refrigerator.

CAUTION: During unpacking, the packaging materials (polythene bags, polystyrene pieces, etc.) should be kept out of reach of children.

WARNING: The refrigerator must be installed and secured according to these instructions to prevent instability and potential hazards.

- Unpack the refrigerator and take out the installation accessories from the refrigerator.

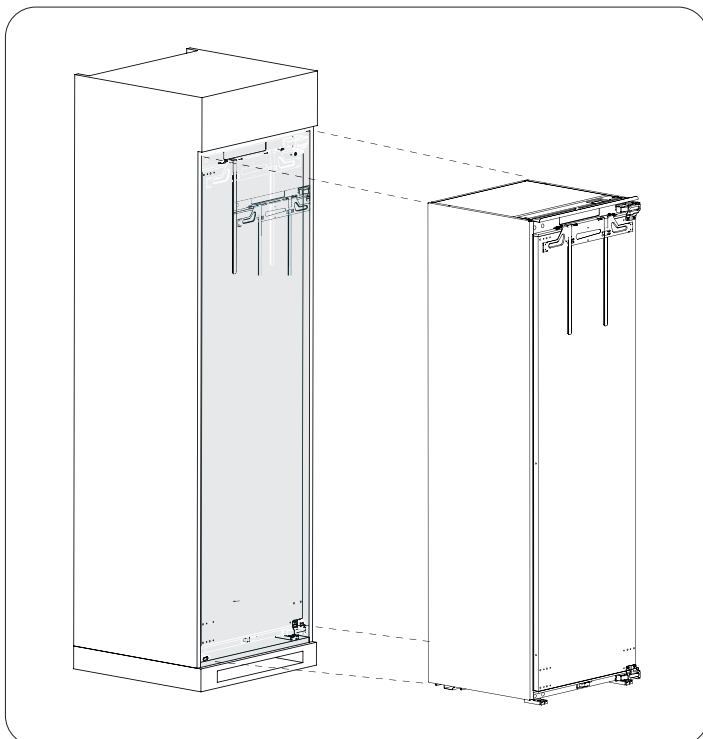

Securing the Refrigerator to the Cabinet

1. Close the refrigerator door, take out the power cable and plug it in the socket or through the cable hole in the cabinet.

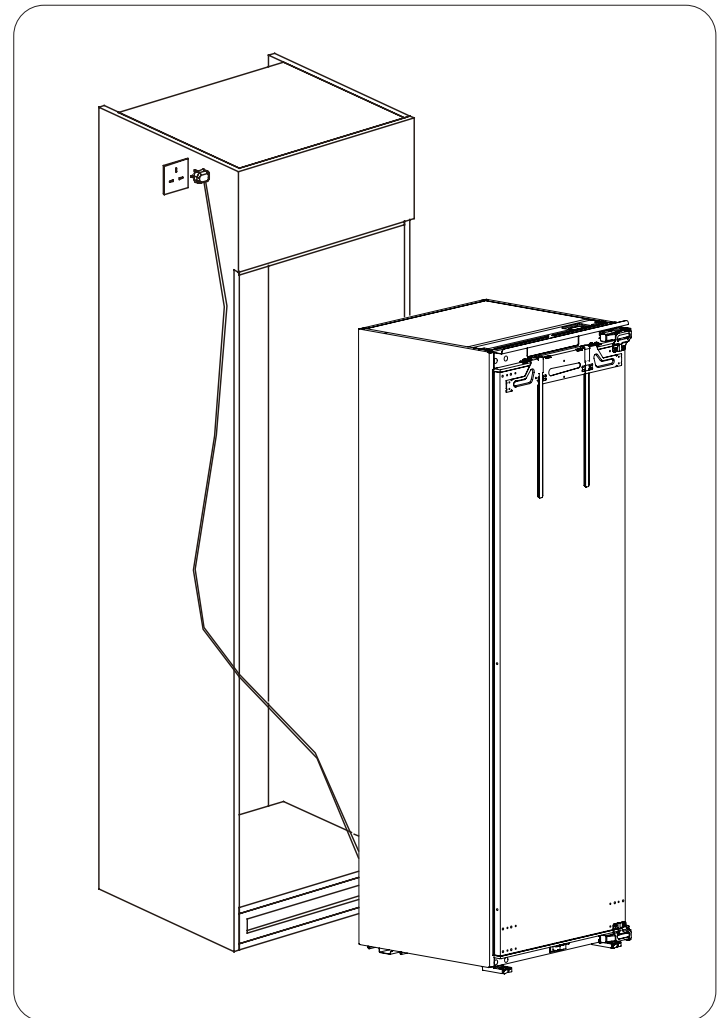

2. Install the Upper and Lower Hinge Decorative Covers on the sides of the hinge, as shown below.

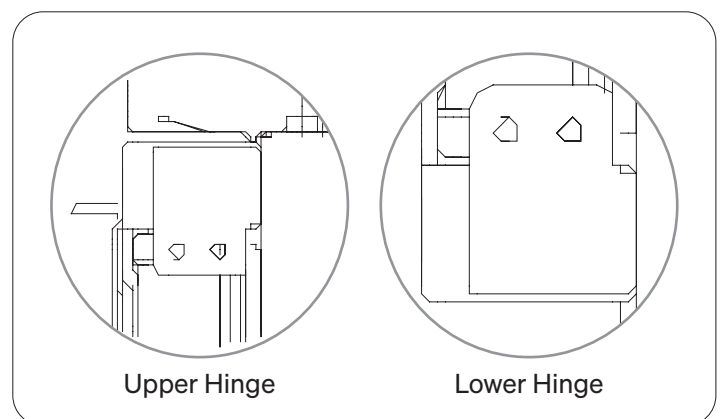

Note: The diagrams and images in this user manual are for explanatory purposes only. Your appliance's configuration may be different.

Installing Your Refrigerator (Continued)

- Carefully push the refrigerator into the cabinetry. Adjust its position so that it sits close to the cabinet on the hinge side. Ensure the refrigerator hinge and the top baffle flange touches the edge of the cabinet, and the support limit hooks align with the bottom edge of the cabinet. Take care not to pinch or damage the power cable during this process.

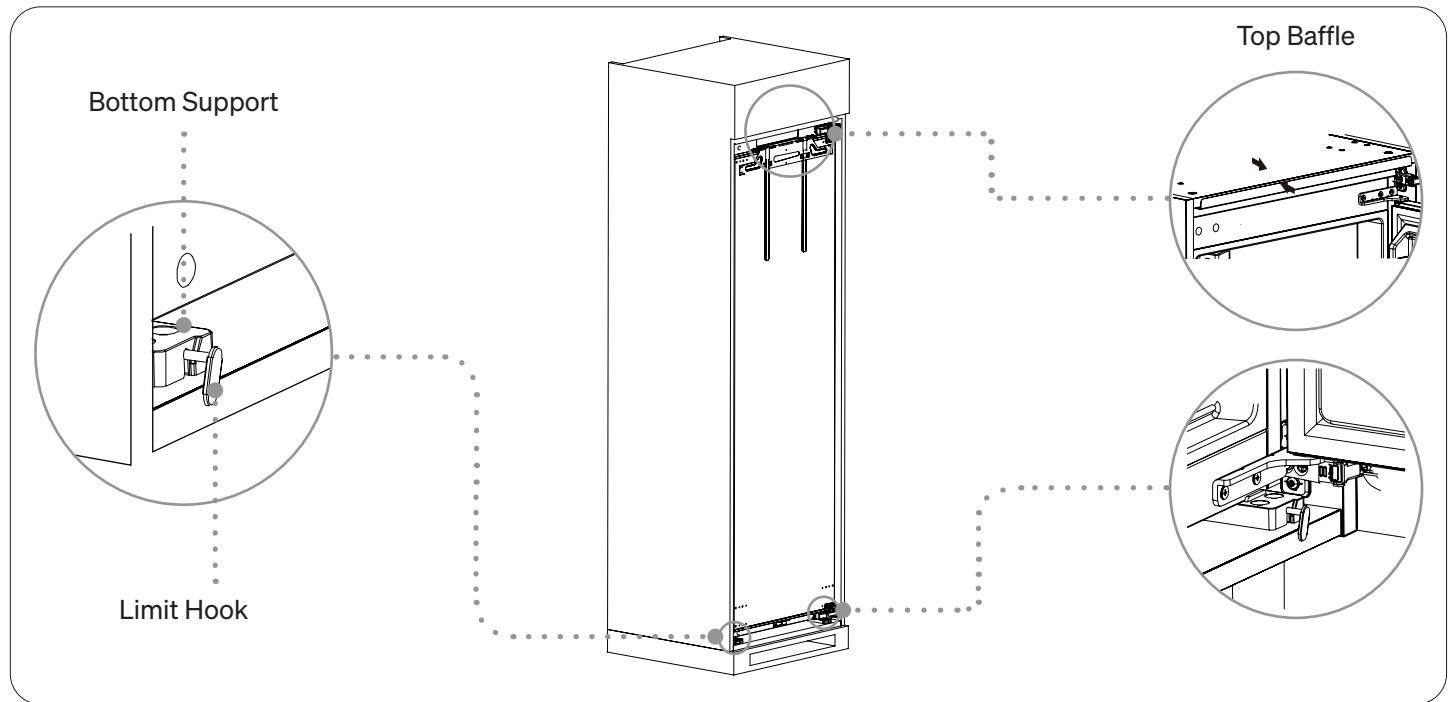

- Secure the bottom support using Phillips Pan Head Self-Tapping Screws (ST4.2×19), and fix the top baffle using Phillips Countersunk Self-Tapping Screws (ST3.9×16).

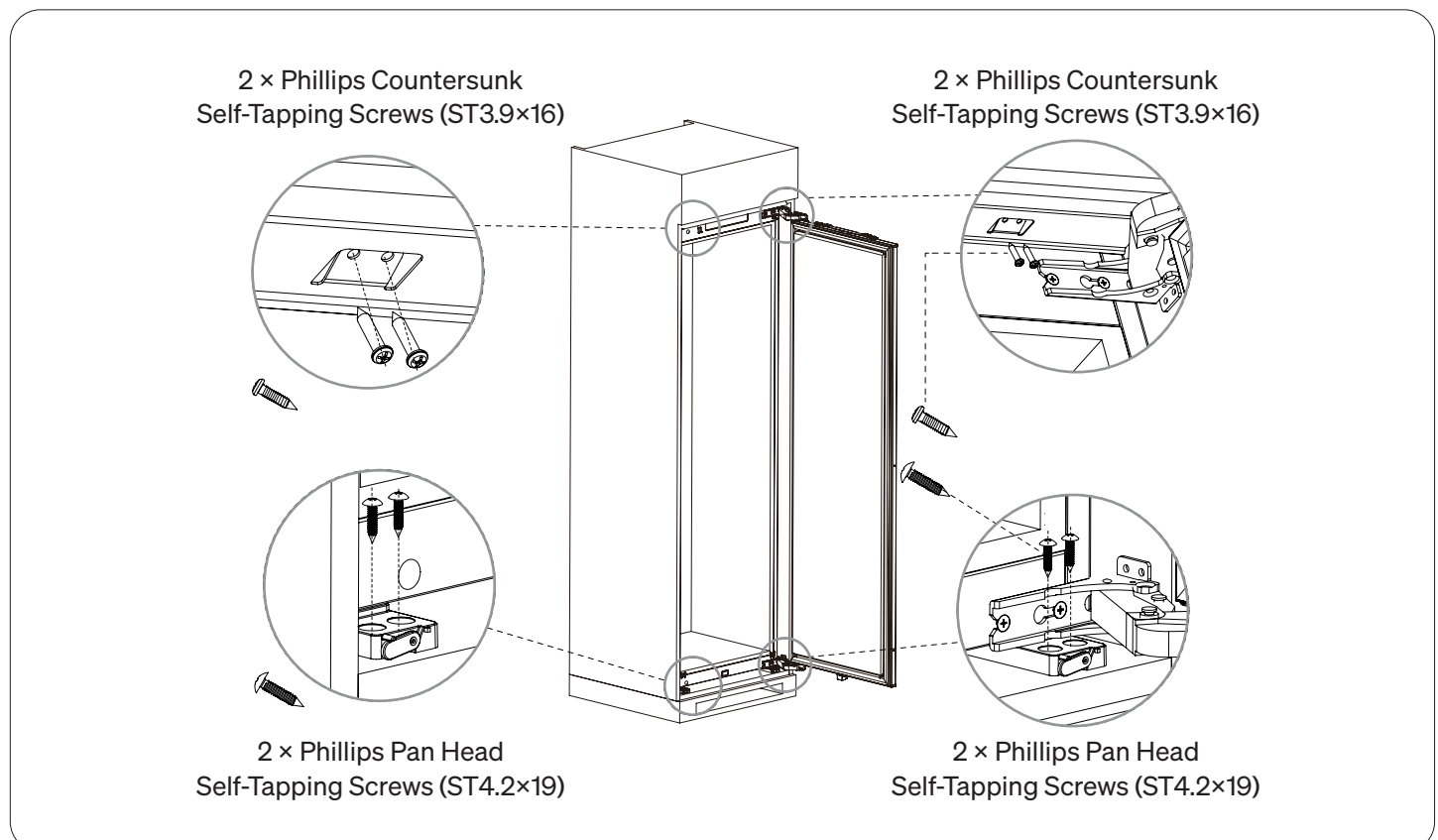

Installing Your Refrigerator (Continued)

5. Open the refrigerator door and secure the hinges to the cabinet side panel using the Phillips Pan Head Self-Tapping Screws (ST4.2 × 13). Hold the door in an upward position while tightening the screws.

WARNING: During installation, make sure the refrigerator is level and correctly aligned.

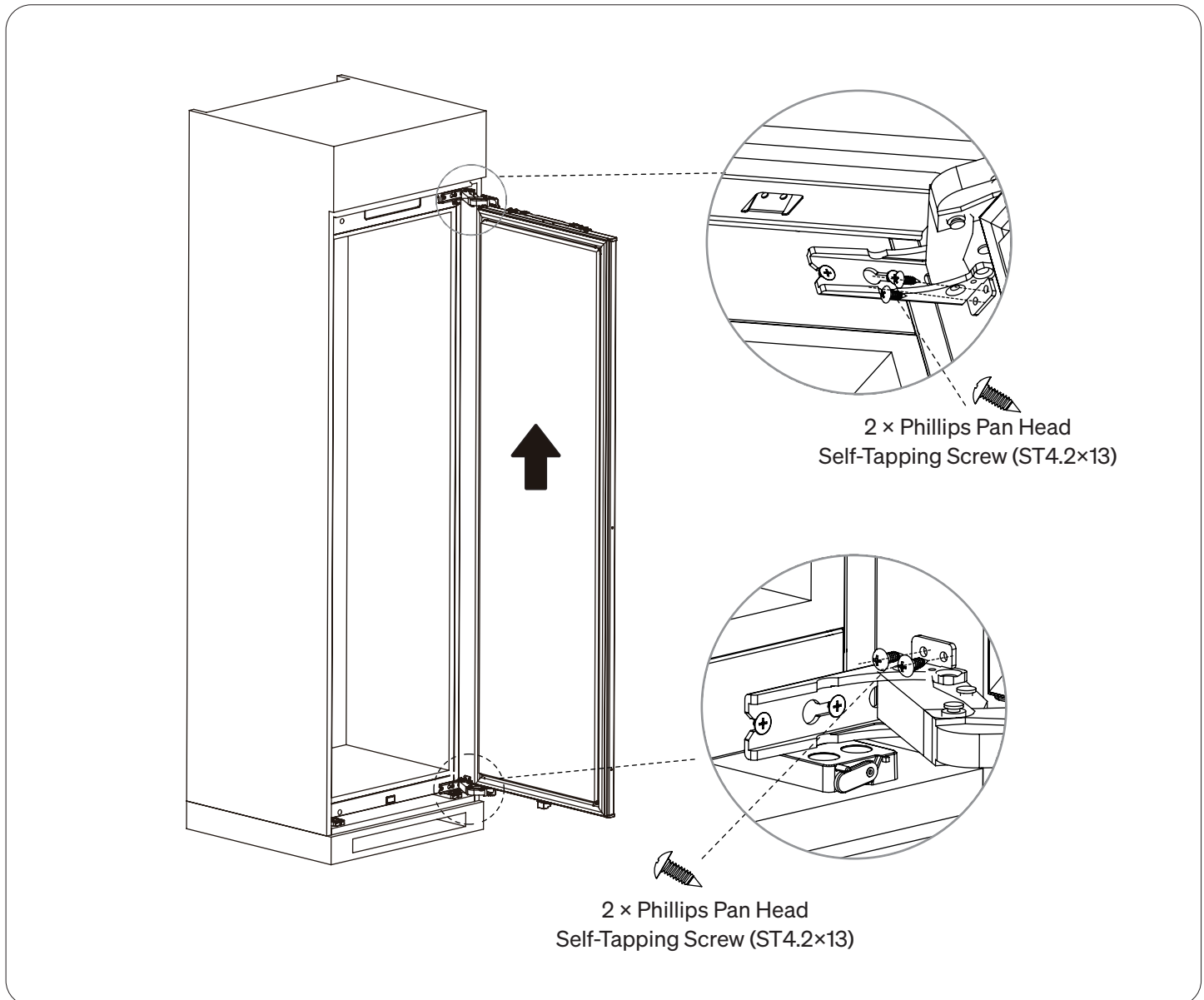

Installing Your Refrigerator (Continued)

Installation of the Cabinetry Door

1. Close the door of the refrigerator. Remove the positioning strip from the door and place it aligning it with the top edge of the cabinet.
2. Adjust the fixing plate assembly so it is centred, then measure the distance (**W**) between the centre of the middle fixing hole and the side edge of the cabinet.
3. Keep the positioning clip in place, then loosen the flange nuts on the fixing plate assembly and remove both the fixing plate assembly and the positioning strip.
4. Turn the cabinet door of the cabinet over so the positioning strip rests against the top edge of the wooden door, and the fixing plate assembly sits flush against the door panel.
5. Adjust the fixing plate assembly so that the distance between its centre line and the side edge of the wooden door equals **W**, then secure it with Phillips Pan Head Self-Tapping Screws (ST4.2×13).
6. Remove the positioning strip once installation is complete.

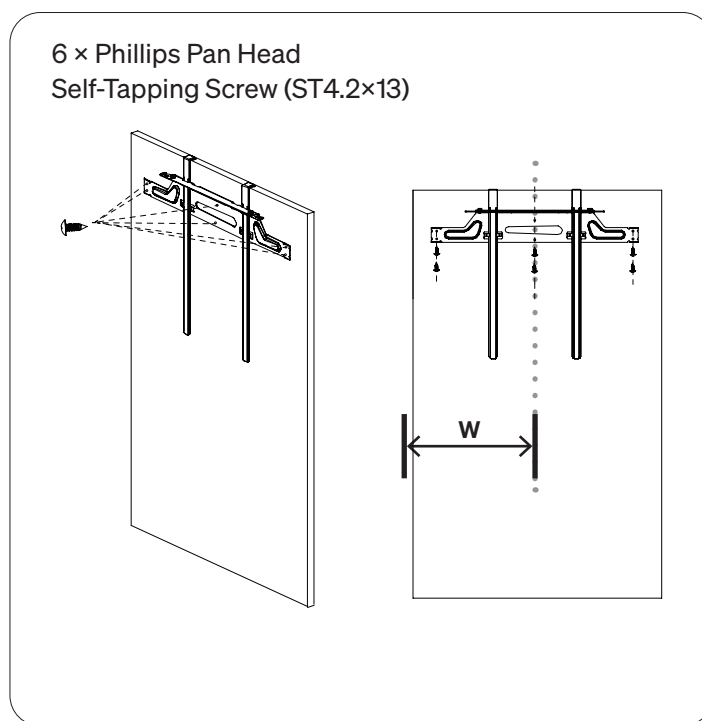
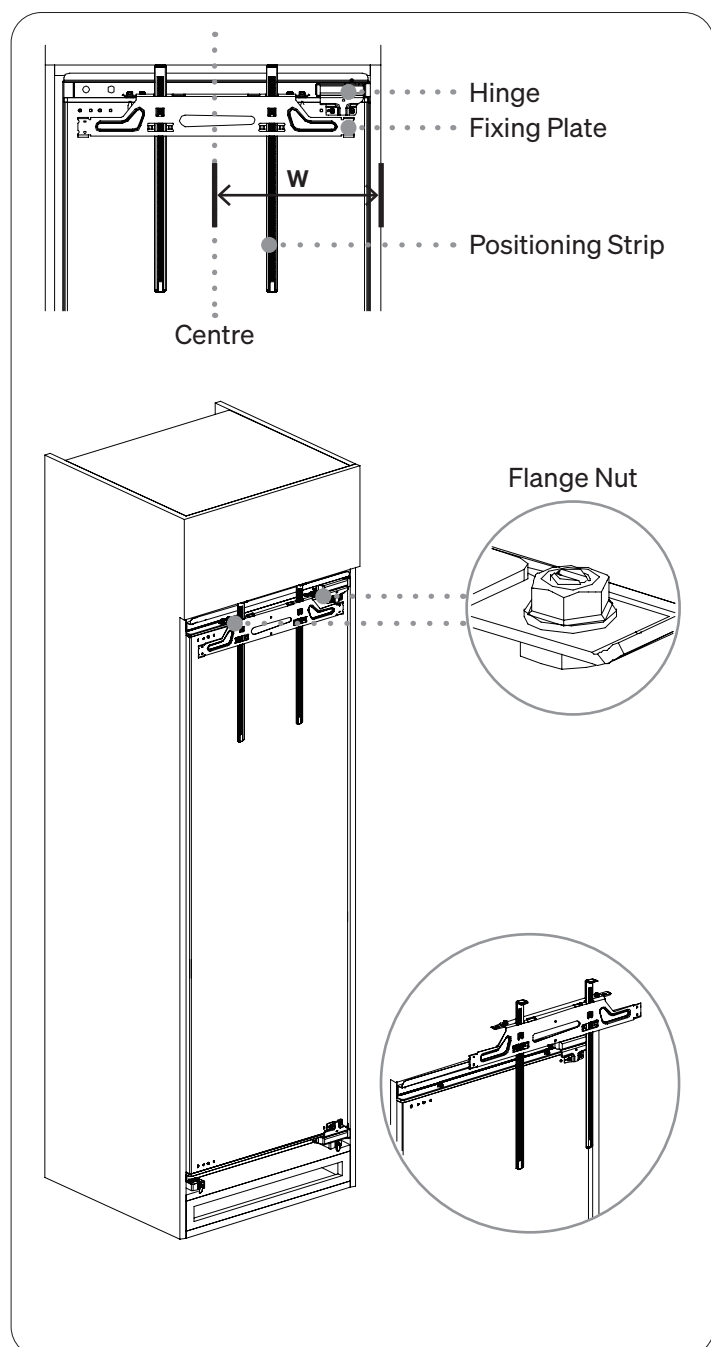

Installing Your Refrigerator (Continued)

7. Place the assembled door onto the Stud of the refrigerator door, then close the door to check the alignment between the wooden door and the cabinet. Once the door closes properly, secure it with flange nuts.

NOTE: Refer to the Adjusting the Cabinetry section for instructions on adjusting the cabinet doors.

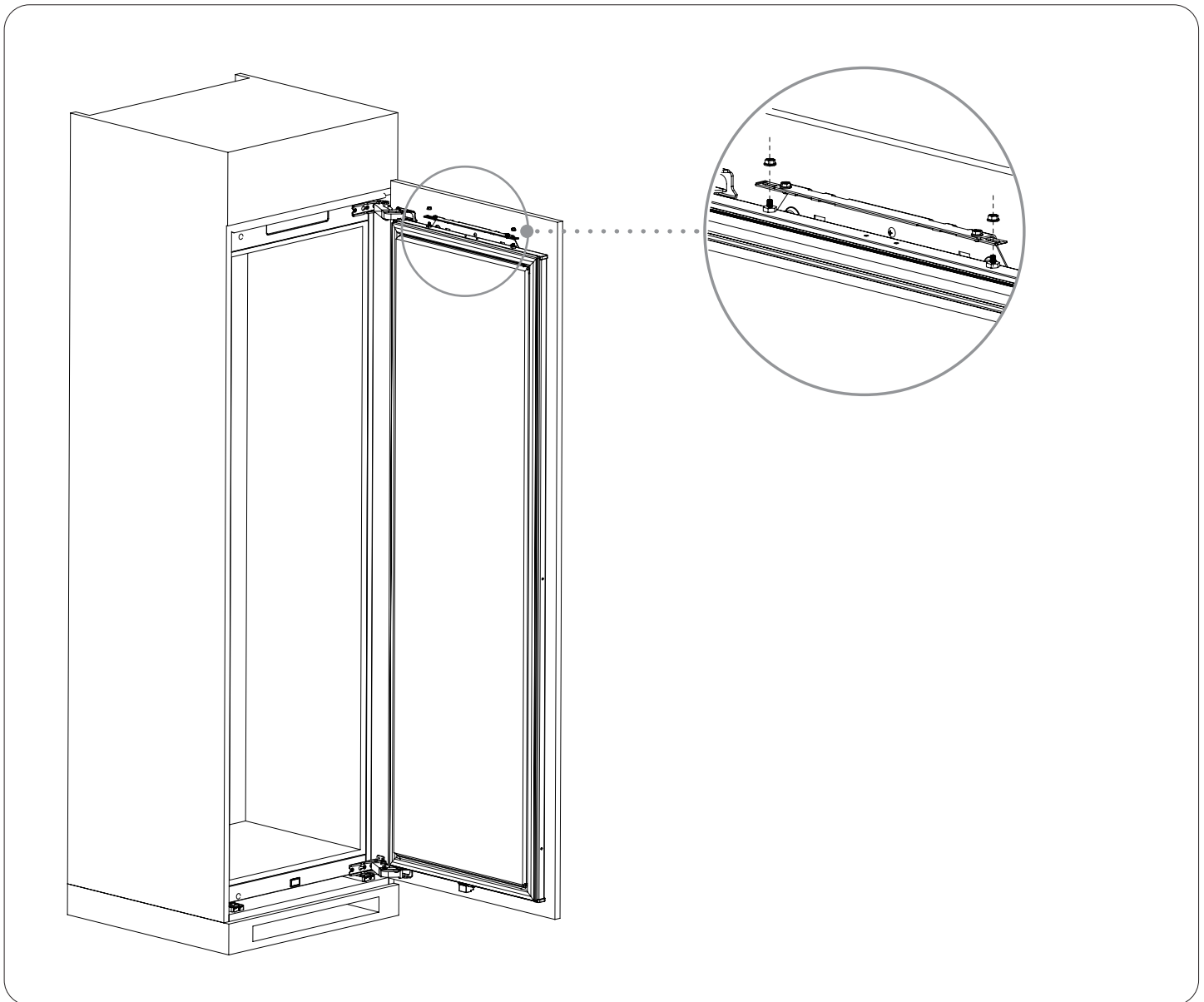

Installing Your Refrigerator (Continued)

Adjusting the Cabinetry

Adjustment of the Upper Cabinet Door

- Adjust the height (**Z**) by approximately 5 mm using a wrench to turn the nuts on the stud.
- Slightly loosen the flange nuts, then move the door left or right to adjust its horizontal position (**X**) by about 5 mm. Once correctly positioned, retighten the flange nuts.
- Slightly loosen the cross recessed hexagon head screws, then move the door forward or backward to adjust its depth (**Y**) by about 5 mm. After adjustment, tighten the cross recessed hexagon head screws.

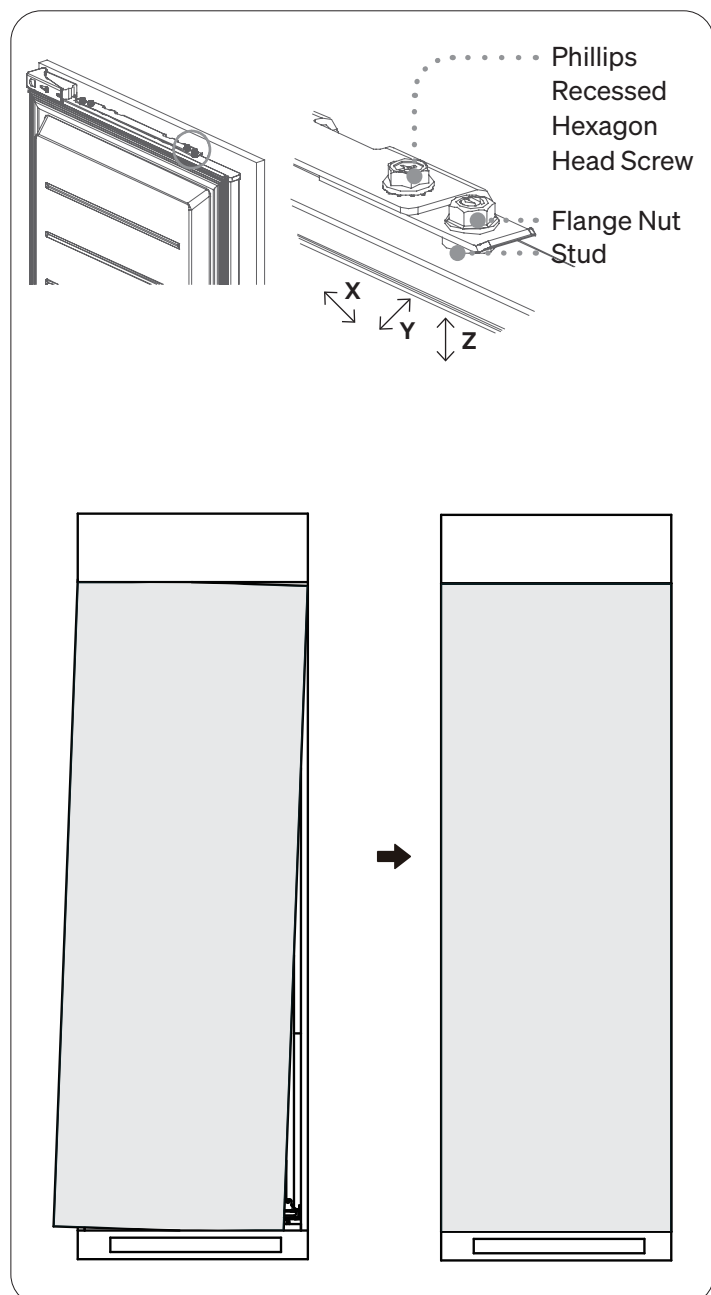

- Attach the refrigerator door to the cabinet door using the side brackets.
- Start by securing the hinge-side bracket first, allowing you to adjust the cabinet door to the correct position.

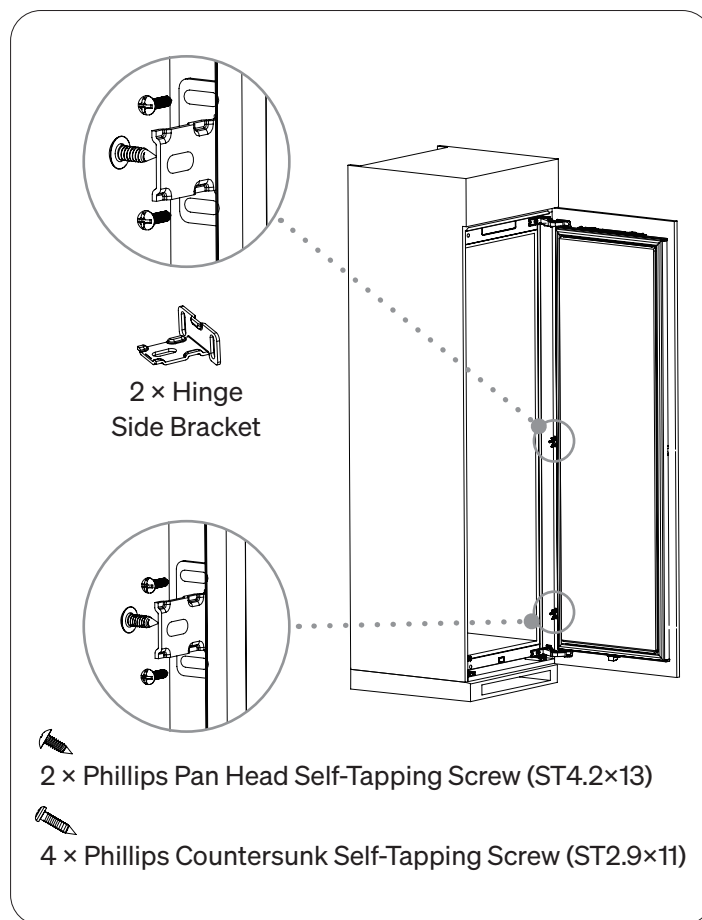

Installing Your Refrigerator (Continued)

Adjusting the Lower Part of the Cabinetry Door

If the Lower Part of the Cabinetry Door appears tilted, adjust it as follows:

- Slightly loosen the side bracket Phillips Countersunk Self-Tapping screws (ST2.9×11). Move the door left or right (X) by up to 5 mm to align it correctly, then tighten the Flange Nuts once adjusted.
- Slightly loosen the side bracket Phillips Pan Head Self-Tapping screws (ST4.2×13). Move the door forward or backward (Y) by up to 5 mm to adjust its depth, then retighten the screws once properly aligned.

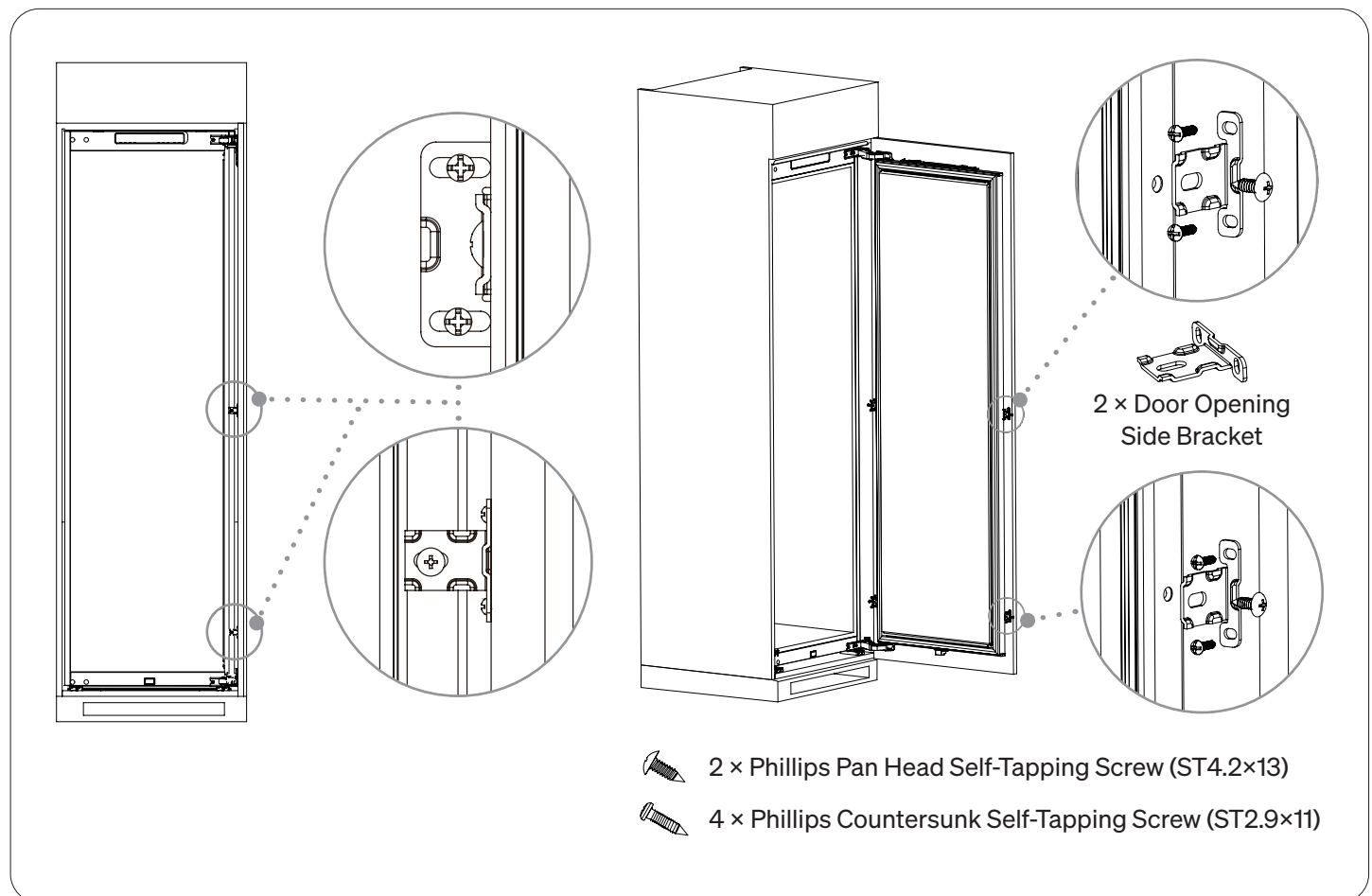

Once the cabinet door is correctly aligned, secure the side bracket on the door opening side.

Installing Your Refrigerator (Continued)

Completing the Installation

To complete the installation, attach all covers and the sealing strip as listed below. This ensures the refrigerator doors and components are properly protected and the unit has a finished appearance.

- A. Install the Top Baffle Covers × 2
- B. Install the Top of Door Decorative Cover × 1
- C. Install the Bottom Support Covers × 2
- D. Install the Hinge Decorative Covers × 2
- E. Install the Hinge Side Bracket Decorative Covers × 2
- F. Install the Door Opening Side Bracket Covers × 2
- G. Install the Sealing Strip × 1

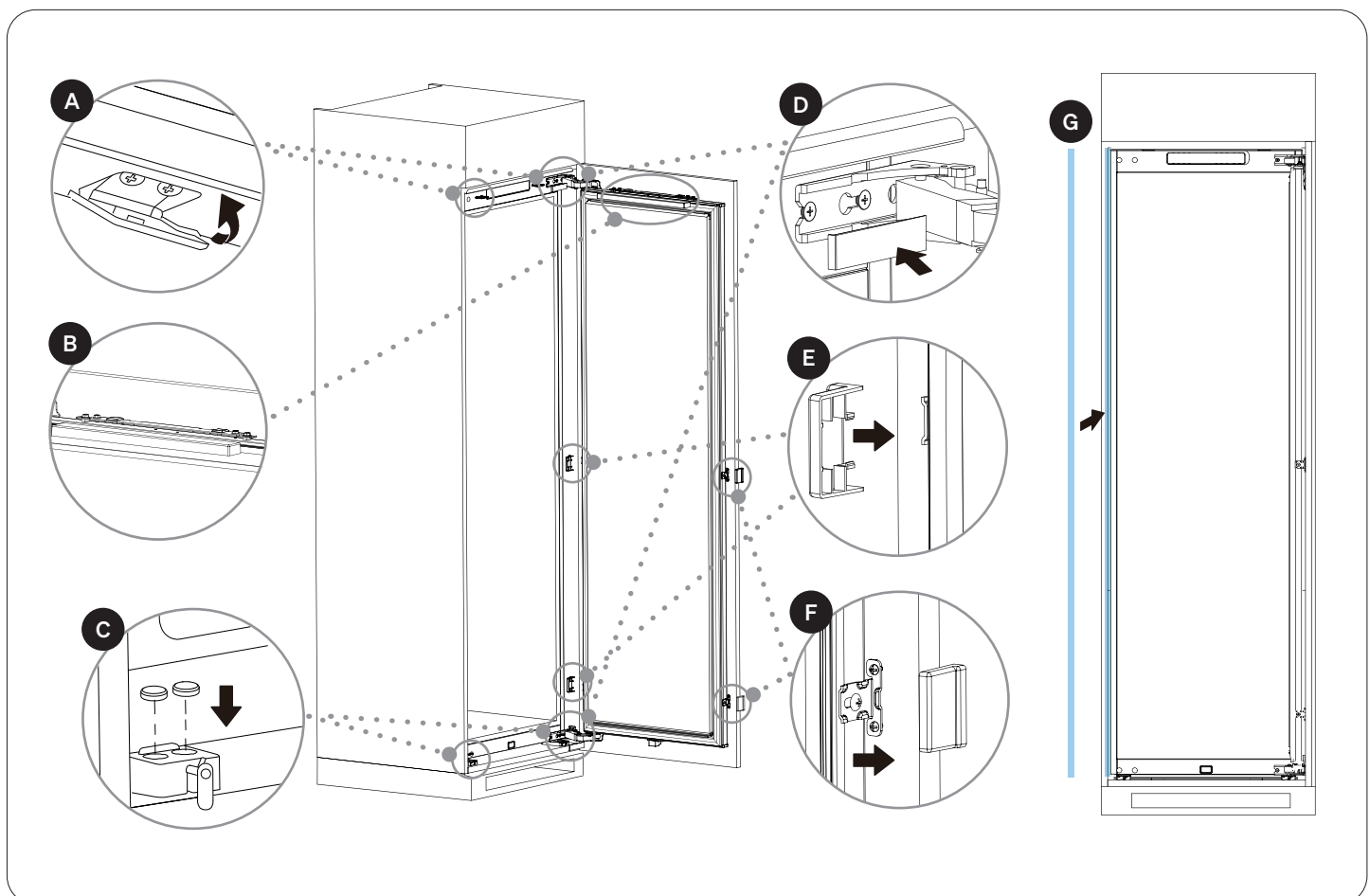

Note: The diagrams and images in this user manual are for explanatory purposes only. Your appliance's configuration may be different.

Operating Instructions

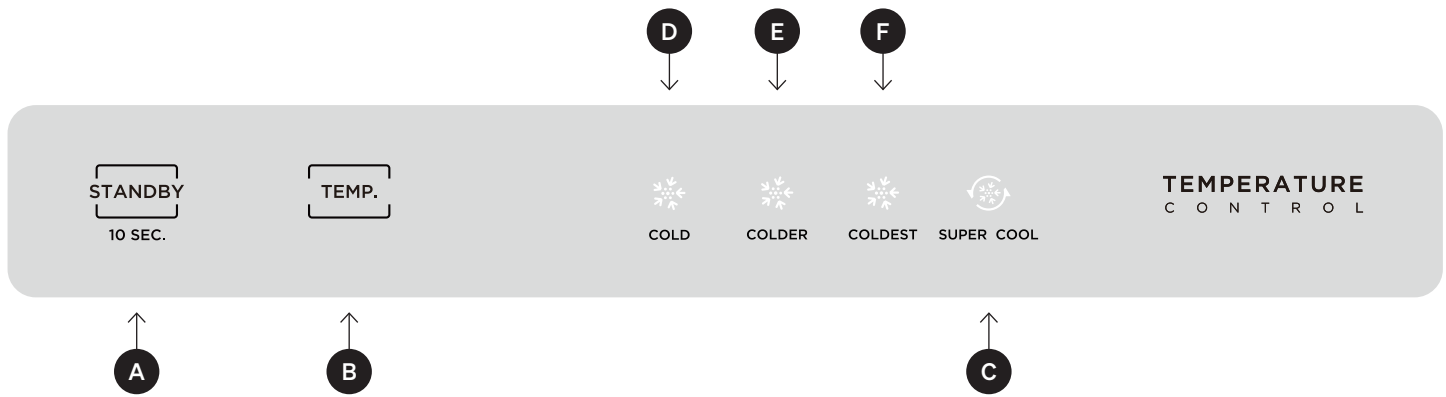

Control Panel

A. Standby Mode Button

B. Temperature Adjustment Button

C. Super Cool Indicator

D. Cold Temperature Setting Indicator (8°C)

E. Colder Temperature Setting Indicator (4°C)

F. Coldest Temperature Setting Indicator (2°C)

Operating Instructions (Continued)

Before First Use

- Ensure that the refrigerator is correctly installed following the Installing Your Refrigerator section.
- Remove all packaging, including foam backing and tape securing shelves and door trays.
- Before use, clean the unit with a warm, soapy cloth, and dry thoroughly.
- **CAUTION:** You must allow the fridge to settle for at least 24 hours prior to switching the power on.
- The fridge may have an odour to it at first use. This will dissipate as the appliance cools.
- **IMPORTANT:** If you switch the appliance off, you should allow five minutes before switching it on again to prevent unnecessary damage to the compressor.

Starting Your Refrigerator

When the refrigerator is powered on for the first time, all display icons will appear for approximately 3 seconds, accompanied by a power-on chime. The display will then switch to normal operation mode.

The default temperature of the fridge is set to 4°C (Colder).

To adjust the temperature in your refrigerator, press the **Temperature Adjustment Button (B)** once to activate the adjustment mode. Then, continue to press the button to cycle through the available temperature settings to cycle through the available temperatures ranging from 2°C to 8°C.

After 15 seconds without any further adjustment, the refrigerator will operate according to the selected temperature.

Super Cool Mode

To activate Super Cool mode, press the **Temperature Adjustment Button (B)** until the **Super Cool Indicator (C)** is illuminated. In this mode, the Refrigerator's temperature is set at 2°C and the compressor will run at maximum performance for faster cooling.

The mode automatically deactivates and revert to the previous setting after running for 6 hours or if the temperature setting is changed.

Door Open Timeout Alarm

If the refrigerator door remains open for more than 120 seconds, a chime will sound to alert you.

Close the door or press any button to stop the alarm.

Standby Mode

Standby Mode is essentially a temporary power-off state for the refrigerator. When activated, it pauses all cooling operations. The fridge stops running but the appliance remains powered on and ready to restart quickly.

It's useful when you're cleaning the fridge or need to defrost it or if the fridge is not in use for a short period but you don't want to unplug it.

Press and hold the **Standby Mode Button (A)** button for 10 seconds to enter Standby Mode. All indicators will turn off. The refrigerator will stop operating while in this mode.

To exit Standby Mode, press and hold the **Standby Mode Button (A)** button again for 10 seconds. The display will return to the same state as before Standby Mode was activated.

Food Storage Advice

The Fridge Compartment is suitable for freezing fresh food.

CAUTION: Avoid direct contact between food, especially oily items, and the refrigerator liner. Promptly clean any oil or oily food stains to prevent prolonged contact, which can lead to liner corrosion and cracking.

If the refrigerator is left empty for extended periods, switch it off, defrost, clean, dry, and leave the door open to prevent mould growth.

Refrigerator Storage Cautions

- Allow hot foods to cool to room temperature before placing them in the fridge.
- Keep the door closed as much as possible to maintain temperature and efficiency.
- Do not block air vents to ensure even cooling throughout the appliance.
- Store raw meat and seafood in sealed containers to prevent cross-contamination.
- Clean food-contact surfaces and drainage areas regularly.
- Wrap foods or store them in airtight containers to prevent odours and frost damage.
- Shelves and drawers can be removed or adjusted to suit different food sizes.

Crisper Drawer

The Crisper Drawers are designed to keep fruits and vegetables crisp and full of flavour. This drawer helps maintain an ideal humidity level to preserve the freshness and texture of your produce for longer. For best results, store unwrapped fruits and vegetables separately to reduce odour transfer and prevent moisture build-up.

Mobile Box Drawer

The Mobile Box Drawer is a versatile storage compartment that can be repositioned within the refrigerator to suit your needs, just like a shelf. It provides flexible storage space for items of varying sizes but does not offer any humidity control or preservation features. Use it to organise your food efficiently and make the most of your fridge space.

Food Storage Guide

- Dairy and Eggs: Store in the fridge compartment. Use within the date shown on the packaging. Keep butter sealed to prevent odour absorption.
- Meat and Poultry: Store covered on a plate or in a sealed container. Keep cooked and raw meat separate.
- Fish and Seafood: Store in a sealed container or wrap tightly. Use within 1–2 days of purchase.
- Leftovers: Keep in covered containers and use within 1–2 days. Reheat only once until piping hot.
- Fruits and Vegetables: Store in the Moisture Zone drawer. Some fruits (like bananas, mangoes, and avocados) should only be refrigerated once ripe. Avoid storing certain fruits below 6 °C to prevent browning or softening.

Fridge Storage Recommendations

- **Temperature Settings:**
Setting the temperature too high or too low can shorten the shelf life of your food, resulting in increased food waste.
- **Optimal Fridge Temperature:**
It is recommended to set the fridge temperature to +4°C and arrange food in a way that ensures optimal use of the cooling conditions inside, providing the best environment for food preservation.

Food Type	Fridge Location
Butter & Cheese	Upper Door Tray
Jams, Jars, Small Bottles, Tubes & Eggs	Middle Door Trays
Drink Cartons & Bottles	Lower Door Shelves
Fruit, Vegetables, Salad, Meat, Sausages, Cheese, Dairy Products, Canned Food and Cans, Drinks, Bottles and Tubes	Shelves and Crisper Drawer Lowest Shelf Above Crisper

Note: The above is a recommended guide.

Cleaning & Maintenance

Prior to Cleaning Your Refrigerator

- Before cleaning, always power off the unit, then turn off the power switch and disconnect the power plug.
- Ensure no water enters the switch, control panel, door lamp, or top control box during cleaning.

LED Light Replacement

Only a professional should replace the LED light source in this product.

Cleaning

Precautions for internal and external cleaning of the refrigerator:

- Use a mild cleaner to remove dirt from the exterior of the refrigerator, then wipe with a clean, soft cloth, and allow the refrigerator to dry naturally.
- When cleaning the door sealing strip, use clean water, wipe with a dry cloth, and allow it to dry naturally. For the refrigerator body (excluding the door sealing strip), use a wet soft cloth with warm water or neutral cleaner for wiping.
- Do not directly flush the refrigerator with water as it may affect electrical insulation properties.
- Avoid using metal wipers, wire brushes, coarse abrasive cleaners, strong alkaline detergents, or flammable or toxic cleaning fluids to clean the refrigerator.
- After cleaning, connect the power plug of refrigerator and power on the refrigerator.

Power Failure

Short-term power failures usually do not significantly affect the refrigerator's temperature. However, during prolonged power outages, reduce the frequency of opening the refrigerator and avoid placing fresh foods inside to prevent a rapid increase in temperature. If you anticipate a power failure, you can activate the Super Cool function in advance to maintain the refrigerator's temperature at the lowest setting.

Shutdown

Generally, it's not advisable to shut down the refrigerator or turn off the power switch as it may affect the refrigerator's lifespan.

Energy Saving Tips

- Make sure to keep the refrigerator away from heat source and direct sunlight.
- Before storing hot foods, cool them to room temperature and then put into refrigerator.
- Close the door timely, reduce the opening frequency, and shorten the opening time.
- When defrosting frozen foods, you can into the refrigerator, this will also assist in refrigeration of the refrigerating chamber.
- Make sure that the temperature sensor is not covered or blocked by foods, and keep proper distance with foods.

Cleaning & Maintenance (Continued)

Cleaning the Door Trays

To remove a door tray, hold it with both hands and squeeze the sides as shown in the diagram. Push the tray upward to release it.

After cleaning the tray, you can reinstall it in its original position or at your preferred height.

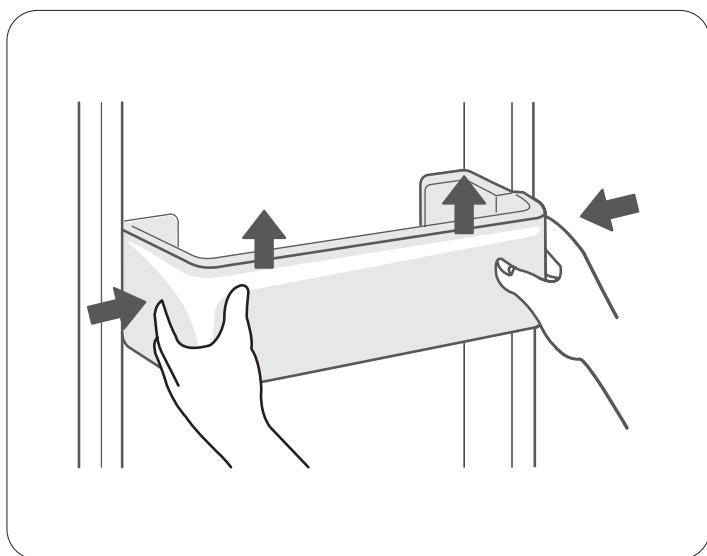

Cleaning the Crisper Drawers

Remove all items from the crisper drawers. Hold the handle and pull the drawer out until it stops.

Then lift the front of the drawer slightly and pull it out completely.

After cleaning, slide the drawer back into place.

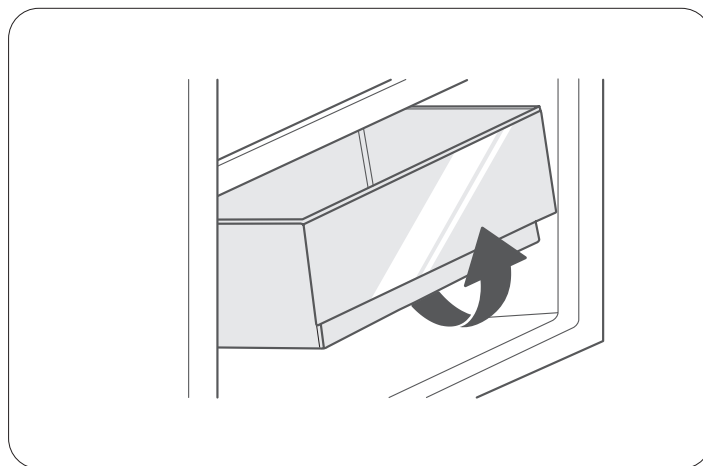

Cleaning the Glass Shelves

The rear of each shelf sits against a backstop inside the fridge. To remove a shelf, lift it slightly and then pull it out.

After cleaning, you can adjust the shelf height as needed before placing it back.

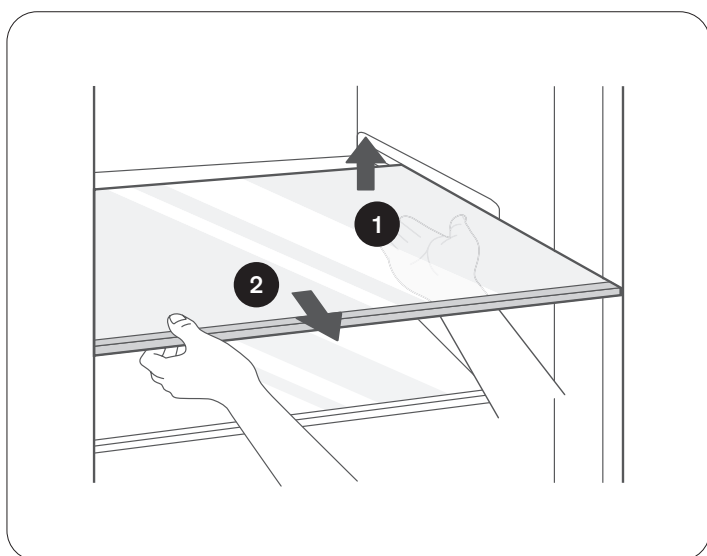

Troubleshooting

Long Chilling Time

In high ambient temperatures, the appliance may take longer to begin chilling.

Dew Drops

When external air flows into the cool inner surface of the fridge, dew drops can form. During humid or rainy weather, dew drops can also form on the outer side of the fridge. This is a natural phenomenon. Wipe the water drops with a dry cloth.

Noise

Initially, the fridge may operate at a higher speed to cool quickly, resulting in louder sounds. Once the internal temperature reaches a certain level, the noise will decrease. Various sounds, such as those from the compressor starting or ending its operation, parts expanding or contracting, or control devices operating, are normal.

Long Running Time

In high ambient temperatures or when the fridge is filled with a large amount of fresh food, it may take longer to cool down until the appliance reaches the set temperature.

For Serious Faults

Some minor faults can be fixed by referring to the table above, however if an emergency or serious fault occurs, immediately set all controls to their off positions and disconnect the power from the source.

If a serious fault occurs, DO NOT attempt to repair the Refrigerator yourself, instead wait for a service agent to do so.

For assistance or to organise an authorised service agent contact our After Sales Support by calling 1300 11 4357, or by emailing support@residentialgroup.com.au.

Please note that if a service agent is asked to attend whilst the product is under warranty and finds that the problem is not the result of an appliance fault, then you may be liable for the cost of the call out charge.

The appliance must be accessible for the service agent to perform any necessary repair. If your appliance is installed in such a way that a service agent is concerned that damage will be caused to the appliance or your kitchen, then they will not complete a repair.

Please refer to the Warranty Information to learn more.

Faults Indicators

The following warnings appearing on the display indicate corresponding faults of the refrigerator. Though the refrigerator may still have a freezing function with the following faults, the user shall contact maintenance specialist for maintenance, so as to ensure normal use of the refrigerator

Fault Display	Fault Description
Cold & Colder indicators are illuminated	Temperature sensor fault of the refrigerator
Cold & Coldest indicators are illuminated	Refrigerator defrost sensor fault
Colder & Super Cool indicators are illuminated	Main control PCB or Display PCB Communication fault
Cold & Super Cool indicators are illuminated	Ambient temperature sensor fault

Troubleshooting (Continued)

For Minor Faults

Problem	Possible Causes	Solution
Fridge not operating	<ul style="list-style-type: none"> • Power supply is not turned on or plug is not properly inserted. • Low voltage, power failure or circuit tripped 	<ul style="list-style-type: none"> • Ensure the power cord is firmly plugged in. • Check the household power supply.
Light not working	<ul style="list-style-type: none"> • Appliance is not powered on. • Light globe is faulty. 	<ul style="list-style-type: none"> • Unplug and re-plug the power cord. • Replace the light with a new one.
Fruit or vegetables are frozen	<ul style="list-style-type: none"> • Items placed too close to the back wall where it's coldest. 	<ul style="list-style-type: none"> • Avoid placing food near the back wall of the fridge.
Fridge is over-cooling	<ul style="list-style-type: none"> • Temperature setting is too low. 	<ul style="list-style-type: none"> • Adjust to a higher temperature.
Compressor runs for a long time	<ul style="list-style-type: none"> • High room temperature causing extended operation. • Too much food loaded at once. • Hot food placed inside before cooling down. • Door opened too frequently. • Frost build-up inside is too thick. 	<ul style="list-style-type: none"> • This is normal in warm conditions. • Avoid overloading the fridge. • Let food cool before placing inside. • Limit how often you open the door. • Defrost if frost layer is thick.
Door not closing properly	<ul style="list-style-type: none"> • Door blocked by objects. • Fridge overloaded. • Door gasket (seal) is deformed. 	<ul style="list-style-type: none"> • Avoid overfilling the fridge. • Ensure items are placed neatly. • Warm the gasket, then cool it to restore shape (use a hair dryer or hot water).
Outer wall feels hot	<ul style="list-style-type: none"> • Heat from internal metal tubes is released through the cabinet walls. • Higher ambient temperature during warmer months. 	<ul style="list-style-type: none"> • A warm outer wall is normal. • Allow for ventilation and keep the fridge in a cool, open area.
Cross or vertical beams feel hot	<ul style="list-style-type: none"> • Metal tubing inside beams releases heat to prevent condensation. 	<ul style="list-style-type: none"> • This is normal operation.
Unpleasant odours	<ul style="list-style-type: none"> • Spoiled food. • Strong-smelling items not sealed. • Interior is dirty. 	<ul style="list-style-type: none"> • Remove any spoiled food. • Seal strong-smelling food properly. • Clean the interior thoroughly.
Condensation on the outside	<ul style="list-style-type: none"> • High room humidity. 	<ul style="list-style-type: none"> • This is normal. Wipe away condensation with a dry cloth.
Condensation inside fridge or drawers	<ul style="list-style-type: none"> • Fridge maintains high humidity to keep produce fresh. • High room humidity or frequent door opening. • Door gasket not sealing properly. 	<ul style="list-style-type: none"> • Wipe off condensation with a dry cloth. • Avoid opening doors too often or for long periods.

Purchase Details

Attach your receipt to this page

For future reference, please record the following information which can be found on the rating plate and the date of purchase which can be found on your sales invoice.

Store Details

Store Name

Address

Telephone

| Purchase Date

Product Details

Model No.

Serial No.

Warranty Information

WARRANTY TERMS AND CONDITIONS REFRIGERATORS

This document sets out the terms and conditions of the product warranties for Residentia Group Appliances. It is an important document. Please keep it with your proof of purchase documents in a safe place for future reference should you require service for your Appliance.

1. In this warranty
 - (a) 'acceptable quality' as referred to in clause 10 of this warranty has the same meaning referred to in the ACL;
 - (b) 'ACL' means Trade Practices Amendment (Australian Consumer Law) Act (No.2) 2010;
 - (c) 'Appliance' means any Residentia Group product purchased by you accompanied by this document;
 - (d) 'ASR' means Residentia Group authorised service representative;
 - (e) 'Residentia Group' means Residentia Group Pty Ltd of 165 Barkly Ave, Burnley VIC 3121, ACN 70 600 546 656 in respect of Appliances purchased in Australia;
 - (f) 'major failure' as referred to in clause 10 of this warranty has the same meaning referred to in the ACL and includes a situation when an Appliance cannot be repaired or it is uneconomic for Residentia Group, at its discretion, to repair an Appliance during the Warranty Period;
 - (g) 'Warranty Period' means:
 - (i) where the Appliance is used for personal, domestic or household use (i.e. normal single family use) as set out in the instruction manual, the Appliance is warranted against manufacturing defects for 36 months, following the date of original purchase of the Appliance;
 - (h) 'you' means the purchaser of the Appliance not having purchased the Appliance for re-sale, and 'your' has a corresponding meaning.
2. This warranty only applies to Appliances purchased and used in Australia and is in addition to (and does not exclude, restrict, or modify in any way) any non-excludable statutory warranties in Australia.
3. During the Warranty Period Residentia Group or its ASR will, at no extra charge if your Appliance is readily accessible for service, without special equipment and subject to these terms and conditions, repair or replace any parts which it considers to be defective. Residentia Group or its ASR may use remanufactured parts to repair your Appliance. You agree that any replaced Appliances or parts become the property of Residentia Group.
This warranty does not apply to light globes, batteries, seals, filters or similar perishable parts.
4. Parts and Appliances not supplied by Residentia Group are not covered by this warranty.

Warranty Information

5. You will bear the cost of transportation, travel and delivery of the Appliance to and from Residentia Group or its ASR. If you reside outside of the service area, you will bear the cost of:
 - (a) travel of an authorised representative;
 - (b) transportation and delivery of the Appliance to and from Residentia Group or its ASR, in all instances, unless the Appliance is transported by Residentia Group or its ASR, the Appliance is transported at the owner's cost and risk while in transit to and from Residentia Group or its ASR.
6. Proof of purchase is required before you can make a claim under this warranty.
7. You may not make a claim under this warranty unless the defect claimed is due to faulty or defective parts or workmanship. Residentia Group is not liable in the following situations (which are not exhaustive):
 - (a) the Appliance is damaged by:
 - (i) accident
 - (ii) misuse or abuse, including failure to properly maintain or service
 - (iii) normal wear and tear
 - (iv) power surges, electrical storm damage or incorrect power supply
 - (v) incomplete or improper installation
 - (vi) incorrect, improper or inappropriate operation
 - (vii) insect or vermin infestation
 - (viii) failure to comply with any additional instructions supplied with the Appliance;
 - (b) the Appliance is modified without authority from Residentia Group in writing;
 - (c) the Appliance's serial number or warranty seal has been removed or defaced;
 - (d) the Appliance was serviced or repaired by anyone other than Residentia Group, an authorised repairer or ASR.
8. This warranty, the contract to which it relates and the relationship between you and Residentia Group are governed by the law applicable where the Appliance was purchased.
9. To the extent permitted by law, Residentia Group excludes all warranties and liabilities (other than as contained in this document) including liability for any loss or damage whether direct or indirect arising from your purchase, use or non use of the Appliance.
10. For Appliances and services provided by Residentia Group in Australia, the Appliances come with a guarantee by Residentia Group that cannot be excluded under the Australian Consumer Law. You are entitled to a replacement or refund for a major failure and for compensation for any other reasonably foreseeable loss or damage. You are also entitled to have the Appliance repaired or replaced if the Appliance fails to be of acceptable quality and the failure does not amount to a major failure. The benefits to you given by this warranty are in addition to your other rights and remedies under a law in relation to the Appliances or services to which the warranty relates.
11. At all times during the Warranty Period, Residentia Group shall, at its discretion, determine whether repair, replacement or refund will apply if an Appliance has a valid warranty claim applicable to it.
12. Missing parts are not covered by warranty. Residentia Group reserves the right to assess each request for missing parts in a case by case basis. Any parts that are not reported missing in the first week after purchase will not provide free of charge.
13. To enquire about claiming under this warranty, please follow these steps:
 - (a) carefully check the operating instructions, user manual and the terms of this warranty;
 - (b) have the model and serial number of the Appliance available;
 - (c) have the proof of purchase (e.g. an invoice) available;
 - (d) telephone the numbers shown below.
14. You accept that if you make a warranty claim, Residentia Group and its ASR may exchange information in relation to you, in order to enable Residentia Group to meet its obligations under this warranty.

IMPORTANT

Before calling for service, please ensure that the steps in point 13 have been followed.

Contact Service: Please call 1300 11 HELP (4357)

The Australian Consumer Law requires the inclusion of the following statement with this warranty:

Our goods come with guarantees that cannot be excluded under the Australian Consumer Law. You are entitled to a replacement or refund for a major failure and for compensation for any other reasonably foreseeable loss or damage. You are also entitled to have the goods repaired or replaced if the goods fail to be of acceptable quality and the failure does not amount to a major failure.

EST. 1981

Designed to Enhance

omega

Omega is proudly owned, designed and engineered
in Australia by Residentia Group Pty. Ltd.

@residentia.group
www.residentia.group



E2447