

WDU-3ASAU



CONTINUOUS FEED 3/4 HP
FOOD WASTE DISPOSER
BUILT-IN AIR SWITCH

Abey^{AU}

WDU-3ASAU 3/4 HP

 Observe local authority installation restrictions
WMTS-028 | WM-022985

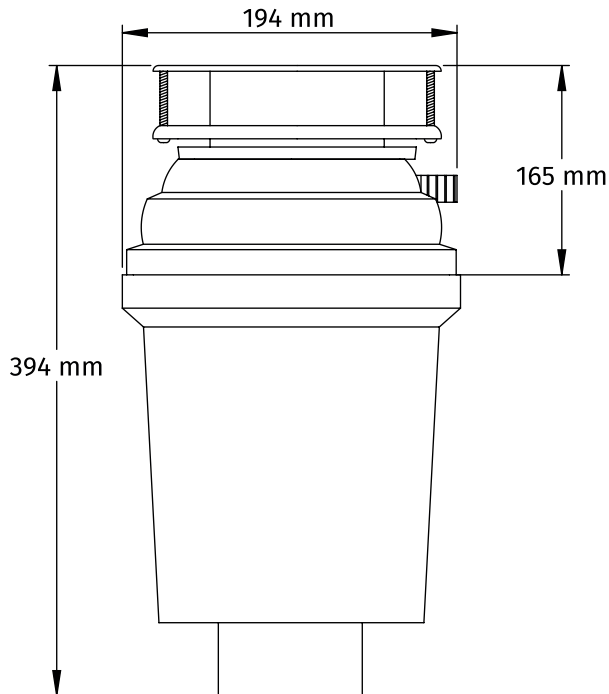

SPECIFICATIONS

HP	3/4
Motor Type	Permanent Magnet
Feed	Continuous
Volts	220-240V
Frequency	50/60 Hz
Motor Speed	2500 RPM
Balance Level	G0.4
Hopper Capacity	1070 ml
Wattage	600 W
Turntable	Stainless Steel
Grind Rings	Stainless Steel
Sink Flange	Stainless Steel
Basket Strainer	Stainless Steel
Drain Elbow	ABS
Bearings	Permanently Lubricated, Sleeve Type
Manual Reset Protector	Protection for Overload and Temp.
Shipping Weight	6.12 kg
Pallet Quantity	64 pcs

This model offers the following features:

- Permanent Magnet High RPM Means High Torque and Less Jams
- Bio-guard Antimicrobial Protection
- Removable Splash Guard
- Stainless Steel Turntable and Grind Rings (Compared to Competitor's Cold-Rolled or Galvanized Steel)
- Factory Installed Power Cord with Plug
- Safe for Properly Sized Septic Tanks
- 3-Bolt Mounting System
- Built-In Air Switch Mounts to Countertop for Safe and Easy Push Button Operation

WARRANTY

THE 3/4 HP ENVIRO GREEN WASTE MACHINE COMES WITH AN 8 YEAR IN-HOME FULL SERVICE LIMITED WARRANTY.