

Integrated Insert Rangehood, 90cm

Series 7 | Integrated

Stainless Steel and Glass



With edge-to-edge extraction, this rangehood is perfectly hidden away in your cabinetry.

- With three fan speeds plus a boost function, select the perfect extraction rate for your cooking
- Powerful maximum air movement of 780m³/hr
- Energy-efficient LED lighting to illuminate your cooking surface
- Wi-Fi enabled for notifications through the SmartHQ™ app

DIMENSIONS

Height	315mm
Width	830mm
Depth	280mm

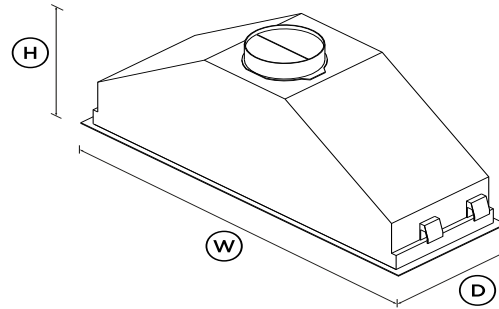

FEATURES & BENEFITS

ACHIEVE THE INVISIBLE

This stylish rangehood fits seamlessly into your kitchen cabinetry, providing ventilation that is as discreet as it is powerful.

EFFECTIVE EXTRACTION

Featuring three fan speeds, plus a boost function, this rangehood provides powerful extraction to quickly remove odours and steam. Odours can linger in the kitchen well after cooking is finished so the timer keeps the hood working for up to 15 minutes before automatically turning off.

EASY CLEANING

Designed for simple removal, the filters are easy to clean and dishwasher safe, while the glass and stainless steel finish is easily wiped clean. The SmartHQ™ app will notify you when to clean the filter to ensure you get the best performance out of your rangehood.

QUALITY MATERIALS

This rangehood comes in a sleek black glass finish with a real stainless steel frame.

FULL SURFACE LIGHTING

Low energy, dimmable LED lights provide superb illumination of the entire cooking surface.

SPECIFICATIONS

Accessories

Aluminium filter	792943
------------------	--------

Accessories (sold separately)

Eave ducting kit	PD-RHK150E
Light bulb	requires service to replace
Recirculation carbon filter	792481
Recirculation diverter	Not required
Roof ducting kit	PD-RHK150T
Side wall ducting kit	PD-RHK150W

Fan ratings

Maximum air movement	780m ³ /hr
----------------------	-----------------------

Installation and cleaning

Dishwasher safe filters	2
Ducted	Top extraction

Recirculation **Optional - top extraction**

Performance

Extraction type **Perimeter**
 Fan speeds **3**
 Filter type **Mesh with perimeter**
 Number of filters **2**

Power requirements

Supply frequency **50Hz**
 Supply voltage **220 - 240V**

Product dimensions

Depth **280mm**
 Height **315mm**
 Width **830mm**

Product information

Control type **Capacitive touch**

Ventilation features

Auto-off/Run-on timer •
 Dimmable lights •
 Filter cleaning alert •
 Light type **LED strip**
 Timer function •
 Wi-Fi connectivity •

Warranty

Parts and labour **2 years**

SKU 50190

The product dimensions and specifications in this page apply to the specific product and model. Under our policy of continuous improvement, these dimensions and specifications may change at any time. You should therefore check with Fisher & Paykel's Customer Care Centre to ensure this page correctly describes the model currently available. © Fisher & Paykel Appliances Ltd 2020

Other product downloads available at fisherpaykel.com

- [↓ Service & Warranty](#)
- [↓ Preliminary Specification Guide Rangehood](#)



A PEACE OF MIND SALE

24 Hours 7 Days a Week Customer Support

T 1300 650 590 W www.fisherpaykel.com