



manual

of buona cucina italiana

Freestanding Cooker with Induction Cooktop 90cm and 80cm models

**Leave a review with details of your new cooker and receive a free gift.
Go to www.glemgas.com.au for details**

INSTRUCTION MANUAL

PLEASE READ THE INSTRUCTION MANUAL CAREFULLY BEFORE USING THE COOKER.

Don't install the cooker if it is damaged. Call 1300 307 917 for assistance

Dear Customer,

Thank you for purchasing our product. This manual has been written to assist you and instruct you in the operation of this appliance. It will help you get the best performance and make full use of the appliance's features. The safety precautions and warnings are listed for your safety and the safety of others when operating this appliance. Please keep this manual in a safe place for future reference.

This appliance has been designed for use in cooking domestic (household) food. Any form of usage other than cooking food is considered dangerous and inappropriate. The manufacturer accepts no responsibility in the event of problems caused by improper use, incorrect use or faulty installation. Only an authorised and licensed installer can install this cooker.

DO NOT ATTEMPT TO INSTALL THIS COOKER YOURSELF

A signed installation certificate indicating the installer's license number and details is required for warranty service.

Glem Gas Australasia Pty Ltd

IMPORTANT

This cooker is for domestic applications. It is NOT suitable for commercial applications of any kind. Do not install the cooker if there is any doubt. Contact Glem Gas Australasia if you require clarification.

Note - Check with an electrician whether the domestic wiring system in your home is suitable without alterations. Any alterations must only be made by a qualified electrician.

This cooker must be installed by a qualified & licensed installer in accordance with these instructions.

If you do not retain proof of correct installation your warranty will be voided. If your cooker is found to be incorrectly installed, you will be liable for all service costs.

If a warranty call is made and the cooker is found to be incorrectly installed, you will be charged for the service call even if the cooker is not repaired.

We will not service an incorrectly installed cooker.

**IF THE APPLIANCE IS DAMAGED DO NOT INSTALL.
CALL 1300 307 917 FOR ASSISTANCE**

"We know that the warnings in this manual are strongly worded but we want you to have a great experience with your new cooker. Too many service calls are due to incorrect installation or incorrect use of the cooker.

These cookers are carefully designed for use in Australian kitchens. When they are used for any other purpose the chance of there being a problem with performance increases."

ENERGY SAVING

Glem Gas and Emilia induction cookers use an Energy Saving system to reduce the total amount of electricity consumed when all zones and the oven are being used.

We balance the load between the cooktop and the oven so when the oven is operating one cooking zone shuts off and another zone drops its maximum power from level 14 to level 13. These zones are marked as energy saving zones. Otherwise the overall performance of the cooktop remains unaffected.

The Energy Saving system allows the cooker to be installed into homes that may not otherwise have enough electrical supply for an induction cooker.

RATED POWER INPUT FOR EACH MODEL:

Glem Gas cooker models

GLIND86FS 7500W = 32A

GLIND96FS 7500W = 32A

GLIND86MB 7500W = 32A

GLIND96MB 7500W = 32A

Emilia cooker models

EMIND86FS 7500W = 32A

EMIND96FS 7500W = 32A

EMIND86MB 7500W = 32A

EMIND96MB 7500W = 32A

TABLE OF CONTENTS

Important safety instructions & first time use	4
Installing the cooker -	6
How an induction cooktop works -	8
Using the induction cooktop -	10
Induction cooktop care and cleaning -	14
Induction cooktop error codes -	15
Using the electric oven -	15
Using the oven timer -	16
Suggested shelf positions -	17
Electric grilling -	19
Cooker cleaning and maintenance -	19
Installation instructions -	20
Electrical connection -	21
Product warranty -	22

IMPORTANT

This appliance is designed and intended for use in domestic household applications. It is not suitable for any non-domestic application.

IT SHOULD NOT BE USED IN A COMMERCIAL ENVIRONMENT.

The appliance guarantee will be void if the appliance is used within a non-domestic environment. This includes semi commercial, commercial or communal applications such as clubs and schools.

Model number location

Model number details are on the data plate fixed to the inside of the flap under oven. The flap is hinged at the bottom so just pull down on the top edge.

Serial number location

The serial number is shown on the data plate fixed to the flap under the oven. You need the serial number when requesting a service call.

Glem Gas & Emilia cookers are manufactured in the Glem Gas factory in Modena, Italy. They have been designed and constructed to meet the following standards:

AS/NZS 60335-1 General Requirements for Domestic electrical appliances

AS/NZS 60335-2-6 Particular Requirements for Domestic electrical cooking appliances

AS/NZS 1044 Electromagnetic Compatibility Requirements.

Surface Temperatures

Surface temperatures for all components comply with the standards. Certain parts of a stainless steel cooker can become very hot during and after use. On all models a cooling fan operates during the cooking cycle and continues to operate afterwards until the cooker cools.

SURROUNDING SURFACES - *If there is a concern regarding the surrounding surfaces you must install an insulating material such as fibre sheet between the cupboards and the cooker.*

FIRST TIME USE

IMPORTANT

Remove all packing material and literature from the upright cooker before connecting the electrical supply. A protective plastic film is coated on the stainless steel both inside and on the outside of the cooker. It must be removed before use. Make sure all plastic has been removed.

Some models have trays with a protective coating; make sure the plastic coating has been removed. To make the plastic film easier to remove we suggest using a Stanley knife to trim along joints and edges before peeling back the film.

Follow the guidelines for first use as shown in this manual.

WARNING: If the surface is cracked, switch off the appliance to avoid the possibility of an electric shock.

WARNING: Metallic objects such as knives, forks, spoons and lids should not be placed on the hotplate since they can get hot

- DO NOT spray aerosols in the vicinity of this upright cooker while it is in operation.
- DO NOT allow young children to use the cooker
- DO NOT touch surfaces when they are hot
- DO NOT store flammable materials in or under the cooker
- DO keep the cooker clean to avoid fires

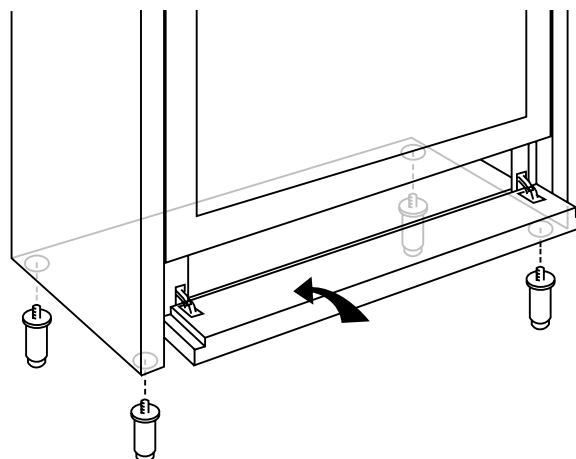

Location of model number and serial number

Record the number here for easy access.

MODEL NUMBER _____

SERIAL NUMBER _____

NOTE: If the upright cooker fails to operate correctly, call Glem Gas Australasia Pty Ltd or their appointed agent for service.

**DO NOT ATTEMPT REPAIRS YOURSELF.
DO NOT MODIFY THIS APPLIANCE
DO NOT INSTALL IF THE COOKER IS DAMAGED
THIS APPLIANCE IS NOT FOR USE IN MARINE CRAFT,
CARAVANS OR MOBILE HOMES.**

WARNING - THIS COOKER IS NOT TO BE USED AS A SPACE HEATER.

The appliance is not intended for use by persons (including children) with reduced physical, sensory or mental capabilities, or lack of experience and knowledge, unless they have been given supervised or instruction concerning use of the appliance by a responsible person for their safety.

Young children should be supervised to ensure that they do not play with the appliance. During use the appliance becomes hot. Care should be taken to avoid touching heating elements inside the oven.

WARNING: Ensure the appliance is switched off before replacing the lamp to avoid the possibility of electric shock.

WARNING - Accessible parts will become hot when in use. To avoid burns young children should be kept away. This appliance is not intended to be operated by means of external timer or separate remote control system

DO NOT use a steam cleaner to clean this appliance

DO NOT use harsh abrasive cleaners or sharp metal scrapers to clean the oven glass door since they can scratch the surface, which may result in shattering of the glass

- If this appliance is installed on a base, measures must be taken to prevent the appliance from slipping from the base
- If the electrical supply is restricted, means of all-pole disconnection must be accessible and incorporated in the fixed wiring in accordance with the wiring rules.
- This appliance must not be installed behind a decorative door
- Danger of fire do not store items on the cooking surface

CAUTION – The cooking process must be supervised. A short term cooking process must be supervised continuously.

WARNING - Unattended cooking with fat or oil can be dangerous and may result in a fire.

WARNING - Do not cover the floor of the oven with, for example, foil or baking tray as this can lead to overheating and damage the enamel

PRODUCT DESCRIPTION

Free standing cooker with electric induction cooktop and multifunction electric oven

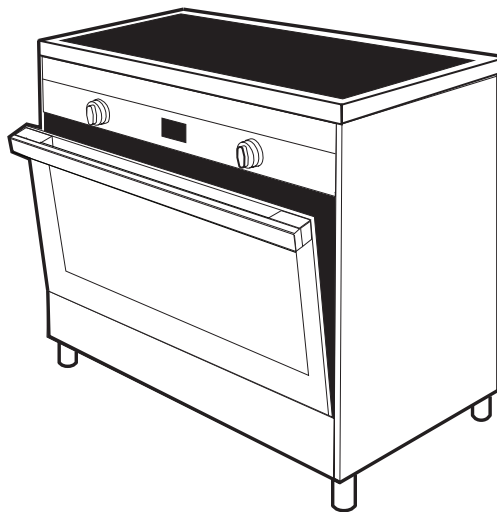

MOVING THE COOKER

When moving the cooker always use two people. When it is installed correctly this cooker complies with all safety requirements. However, it is manufactured from sheet metal stainless steel and care must be taken when moving the cooker as some sharp edges and corners that are not normally intended to be touched could cause injury.

DO NOT LIFT USING THE HANDLE

Lifting by using the handle could break the door so we strongly recommend opening the door and hold inside the top of the oven cavity.

Just be careful to make sure that the door does not close hard onto your hand.

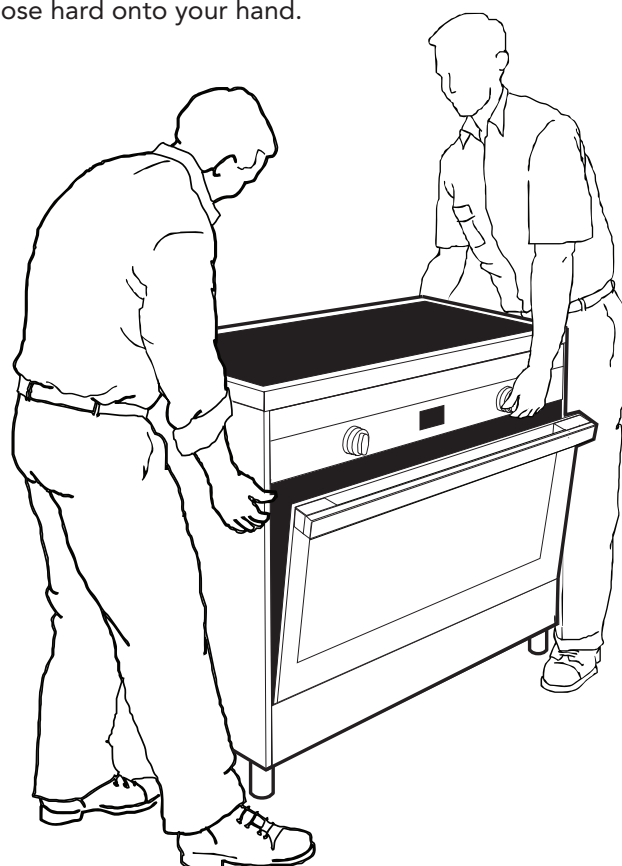

DO NOT DRAG OR SLIDE THE COOKER

Tilting or dragging the cooker may distort the legs. The cooker may become uneven or off balance if the legs are damaged by improper relocation or lifting. Please take care not to slide the cooker



INSTALLING THE ADJUSTABLE LEGS

The cookers are delivered with adjustable height legs that need to be fitted prior to the cooker installation. On some models the legs easily screw into the underside of the cooker. On other models the legs have a new keying system where the screw on the top of the leg is inserted and then slid up the slot so it can be tightened securely. See FIG. 1. You may need to hand tighten the screw into the top of the legs first.

TIP:

Measure the height of the benchtop and the cooker itself and then pre adjust the leg height so when they are installed the cooker will be 10 mm above the height of the bench.

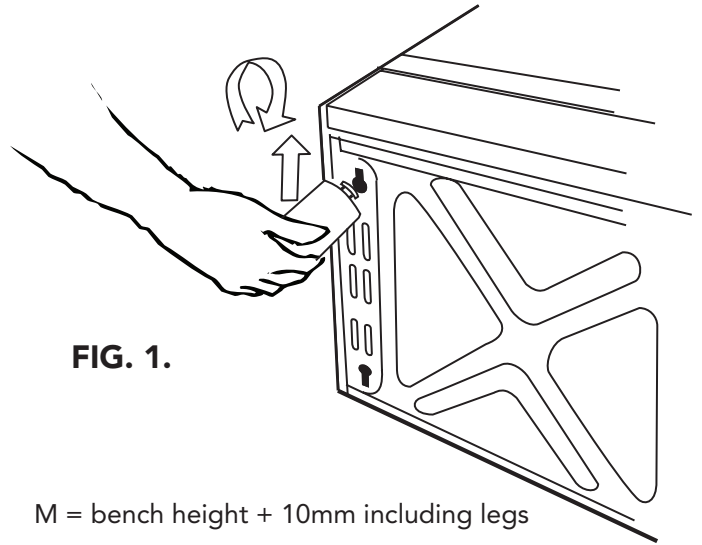

FIG. 1.

$M = \text{bench height} + 10\text{mm including legs}$

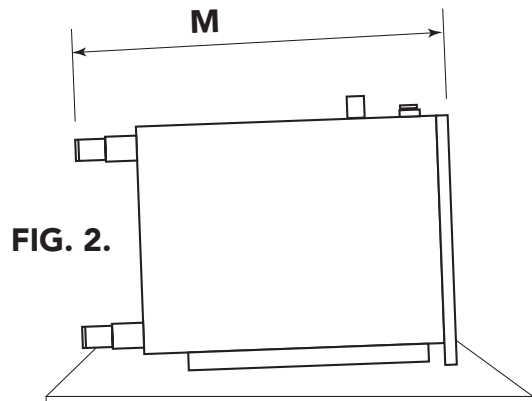
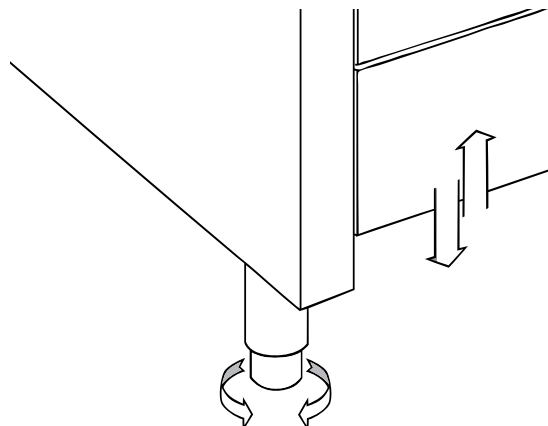

FIG. 2.

Laying the cooker carefully on its back onto the packaging makes the operation of installing the legs very easy.



INSTALLING THE ANTI TILT BRACKETS



Install the legs to the cooker and adjust the height to the desired level. Make sure that this height is precisely correct to what you require.

1. On the rear of the cooker there is a covering panel. Accurately measure the distance from the top of this panel to the floor Height **H**.
2. Mark the same height on the wall against which the cooker is to be installed.
3. Mark the centre of the cooker at the same height on the wall.
4. At a distance of 150mm either side of the centre at the measured height mount the two anti tilt brackets supplied onto the wall.
5. Slide the cooker into position after connecting the chain. The brackets prevent any chance of the cooker tilting forward.

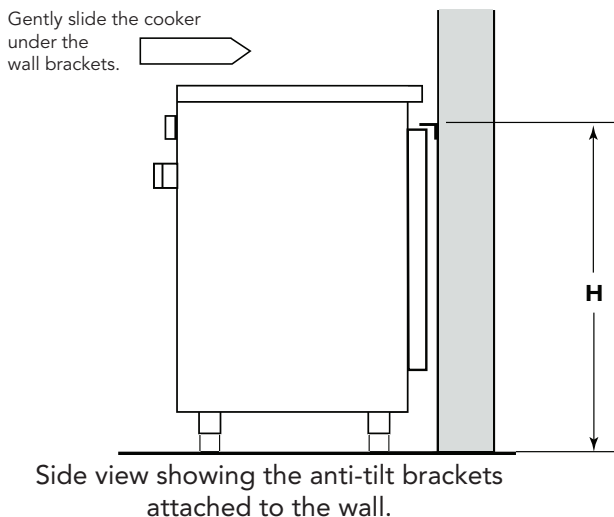
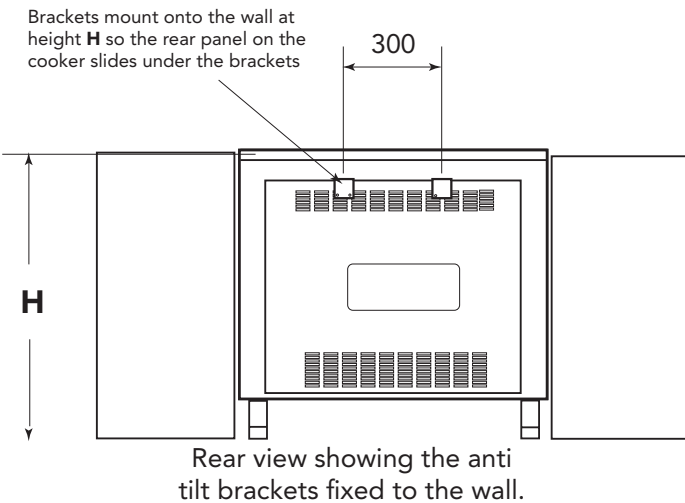

INSTALLING A COOKER ONTO A RAISED PLATFORM

The cooker can be installed without legs onto a platform. The height **H** is 760mm. The platform must be at a height that aligns the cooker at least level with the bench height. Not below.

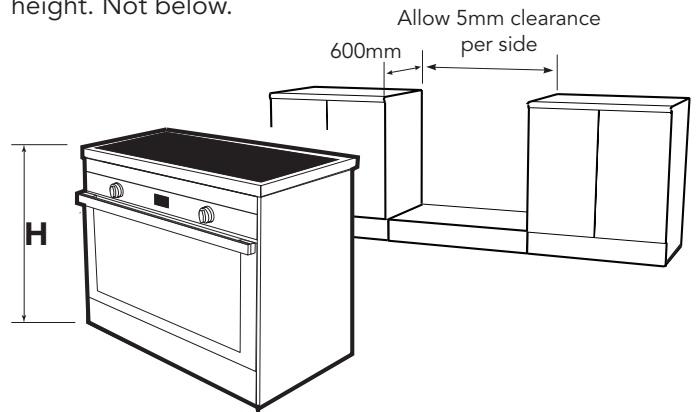

The adjacent cabinet material must be capable of withstanding 85 degrees celcius. We recommend a gap of 5 mm per side for ease of fitting the cooker and to provide an insulating air space.

FOR SAFE USE OF THE COOKER

Oven door: Keep children away from the glass oven door while cooking is in progress.

- DON'T let children sit on or play with the oven door. DON'T use the drop down door as a stool to reach above cabinets.
- DON'T put any weight on an open oven door.
- DON'T line the oven walls or floor with aluminium foil
- DON'T place oven trays or anything onto the floor of the oven when cooking.
- DON'T place inflammable material or plastics in the storage compartment under the oven.
- DO Grill with the door closed.
- DO always turn pan handles to the side or to the back of the cooktop where they can't be knocked or reached by children.
- DO Use the right sized pan: Using the right sized pan makes sense as it saves energy and avoids burnt handles or damage to pots and the hob.
- DO Use of pot holder gloves: Make sure that burners and oven trays are cool before touching them unless you are wearing oven gloves.

CLEANING

This cooker is stainless steel, but harsh detergents and acids can cause rust spots. This is not covered under warranty. Please use only approved stainless steel cleaners. We suggest warm water on a cloth is sufficient to keep the outside of the cooker clean.

Call 1300 307 917 if you are unsure.

Glem Gas Australasia Pty. Ltd. does not accept any responsibility for any damage caused by inappropriate, incorrect or irrational use. For more detailed information refer to the warranty details at the end of this manual. Contact Glem Gas Australasia Pty. Ltd. on 1 300 307 917 for all service enquiries.

BEFORE USING FOR THE FIRST TIME

Remove all packing material, plastic film and literature from the oven before connecting the electricity supply.

Make sure all plastic has been removed before use. Some models have trays with a protective coating; make sure that plastic coating has also been removed. Clean the interior of the oven and all accessories with soap and water and dry them carefully.

Switch the empty oven on to maximum to eliminate grease residues from manufacturing. There may be a slight odour at this time. Run the oven on maximum for a period of 1 hour and open the kitchen windows to ventilate the room. The odor will completely dissipate after a few uses.

The oven is fitted with 3 or 4 guides for positioning trays and racks at different heights. On some models a telescopic runner is fitted to the middle level.

Included with all cookers are two oven shelves, a grill tray and a rack insert for the grill tray.

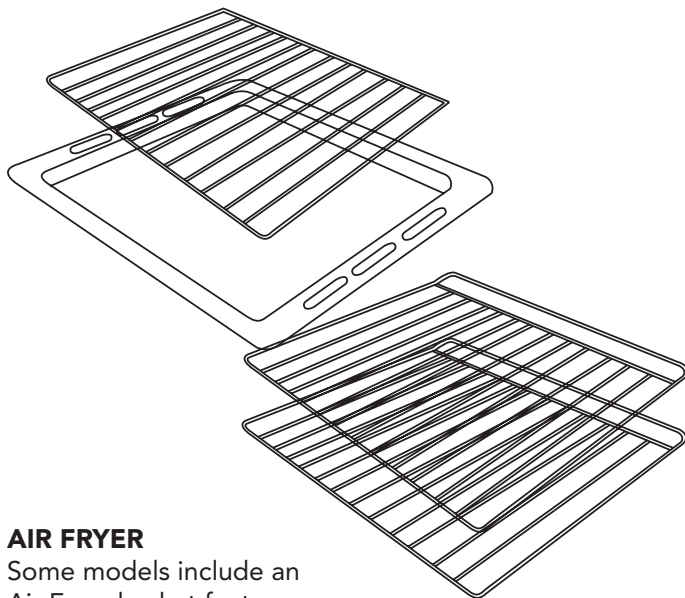
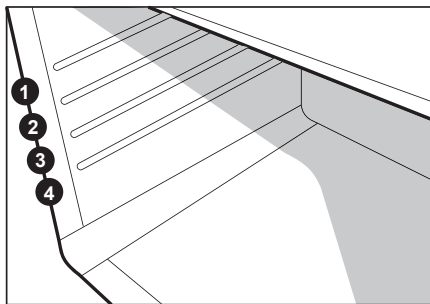

AIR FRYER

Some models include an Air Fryer basket feature.

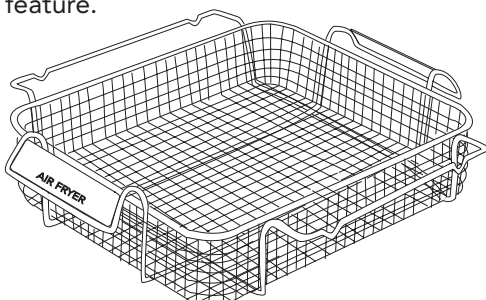

FUNCTIONS OF AN INDUCTION COOKTOP

Cooktop Preparation - Remove and discard any protective film or labels that may be attached to the surface of your cooktop. Wipe the cooktop down with a damp cloth to remove any builder's debris or marks.

What is induction cooking?

Induction cooking is a safe, advanced, and efficient cooking technology. It works by electromagnetic vibrations generating heat directly into the pan, rather than indirectly through heating the glass surface. The glass becomes hot only because the pan eventually warms it up.

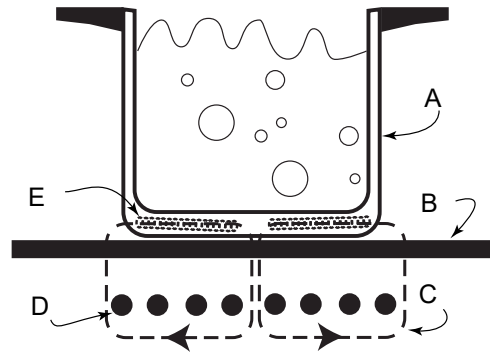
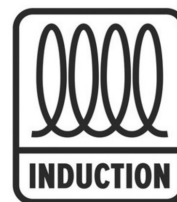

Diagram of induction heating

- A - Magnetic conductive cooking vessel
- B - Ceramic cooktop surface provides insulation and the cooking surface.
- C - Magnetic coil
- D - Coil
- E - Vortex. Relying on an electromagnetic eddy current the internal molecules of the pot are vigorously rubbed together creating heat.

Choosing the right cooking containers Use pots bearing the symbol:



Tip

You can use a magnet to check whether your pans are suitable. A pan is suitable if the base of the pan is attracted by the magnet.

Benefits of induction cooking

- Safer: lower temperature on the glass surface.
- Faster: shorter food heating times.
- More accurate: the cooktop immediately reacts to your commands
- More efficient: 90% of the absorbed energy is transformed into heat and once the pot is removed from the cooktop the heat transmission immediately stops.

BEST USE OF AN INDUCTION COOKTOP

Important: to avoid permanent damage to the glass surface, do not use:

- containers with less than perfectly flat bottoms.
- metal containers with enamelled bottoms.
- containers with a rough base, (to avoid scratching the glass surface).

Never place hot pots and pans on the surface of the cooktop control panel

IMPORTANT WARNINGS:

If the cooktop surface is cracked, switch off the appliance to avoid the possibility of an electric shock.

Metallic objects such as knives, forks, spoons and lids should not be placed on the cooktop since they can get hot.

Suitable Cookware

- Iron cookware
- Enamelled iron cookware
- Steel or enamelled cast iron pots/pans
- Cast iron pots/pans
- Cookware made of 18/0 stainless steel & aluminium if marked as suitable for induction

Unsuitable Cookware

- Containers with bulged bottoms
- Aluminium, brass, copper cookware unless they are clearly indicated as suitable for induction.
- Pots/pans with a diameter below 12 cm
- Cookware with feet
- Ceramic cookware
- Glass cookware

NOTE:

- Do not use the cooktop as a work surface.
- Grains of grit may cause scratches which cannot be removed.
- Only use pans with a clean base and always pick pans up to move them - don't slide the pans on the glass.

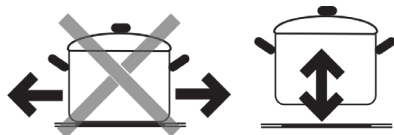

- Be careful with enamelled sheet-steel pans:
 - the enamel may come loose from the steel at high settings when the pan is too dry;
 - high power level settings may cause the base of the pan to warp.
- Never use pans with a misshapen base. A hollow or rounded base can interfere with the operation of the cooktop, causing the appliance to become too hot. This may lead to the glass top cracking and the pan base melting.
- Damage caused by using unsuitable pans or allowing pots to boil dry is excluded from the product warranty.



Recommended pan bottom diameters

IMPORTANT: if the pots are not correctly sized, the cooking zones may not switch on.

For details of the minimum pot diameter that needs to be used on each zone, see below:

Diameter of cooking zone (mm)	Recommended minimum pot diameter (mm)
160	145
180	145
210	180

Energy saving recommendations for best results

- Use pots and pans with a bottom diameter equal to that of the cooking zone.
- Use only pots and pans with flat bottoms.
- Where possible, keep the lid on pots and pans during cooking
- Cook vegetables, potatoes, etc. with a small amount of water to reduce cooking time.
- Use a pressure cooker, it further reduces the energy consumption and cooking time
- Place pots in the centre cooking zone

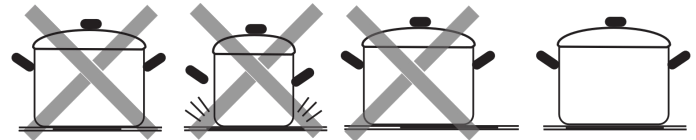

USING THE TOUCH CONTROL PANEL

To select the commands, simply touch (press) the symbols representing them. The controls respond to touch, so you don't need to apply any pressure.

Use the ball of your finger, not its tip (see figure below).



You will hear a beep each time a touch is registered. Make sure the control panel is always clean, dry, and that there is no object (e.g., a utensil or a cloth) covering them. Even a thin film of water may make the controls difficult to operate.

INDUCTION CONTROL PANEL

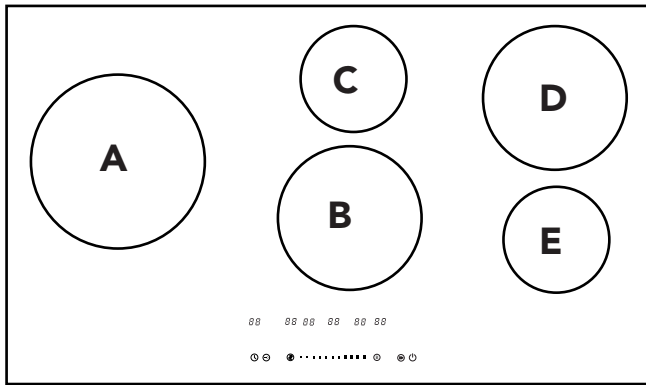

Zone selection key and power level display

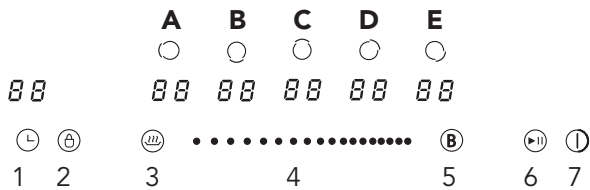

Key	Function
1	Timer
2	Lock
3	Keep warm function
4	Slide touch control
5	Boost function
6	Pause/Restart
7	ON/OFF

USING THE COOKTOP

Switching the cooktop ON

Touch the ON/OFF key (7) for one second.



After power on, the buzzer beeps once and all displays show " _ " indicating that the cooktop is on standby mode.

Place a suitable pan on the cooking zone that you wish to use. Make sure the bottom of the pan and the surface of the cooking zone are clean and dry.

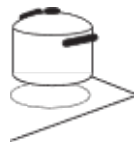

Touching the Indicator A.B.C.D.E. to choose the cooking zone, and the indicator you chose will flash.

Touch the slider to the level you want to set.

Note : if you don't choose a heat setting within 1 minute, the cooktop will automatically switch off.

While cooking, the power level can be changed at any time.

Switching a zone OFF

To switch a zone off when you have finished cooking. Touch the Indicator A.B.C.D.E to choose the cooking zone that you wish to switch off and touch the slider control to zero.

To turn the whole cooktop off touch the ON/OFF symbol.

Residual heat indicator (warning of a hot surface)

When the cooktop has been operating for some time, there will be some residual heat. The indicator **H** will appear to warn you to keep away from that zone.

It will disappear when the surface has cooled down to a safe temperature.

Boost Function

The Boost function provides intensive heating for up to 5 minutes, ideal when boiling water for pasta.

Touch the Indicator A.B.C.D.E. to choose the cooking zone that you want to cook on.

Touch the boost control (5) and the power level indicator will read "P".

To cancel the Boost function, select the zone under Boost mode and touch the slide control to cancel Boost.

NOTE: the Boost function only lasts for 5 minutes after which time the zone will revert to level 14 automatically.

Child Lock Function

You can lock the controls to prevent unintended use for example children accidentally turning the cooking zones on. When the controls are locked all controls except the ON/OFF are disabled.

To lock the controls - touch the lock symbol (2) until the indicator shows 'Lo'



To unlock the controls - touch and hold the the lock symbol for 5 SECONDS. You can now use the cooktop.

NOTE: you can always switch the cooktop off with the ON/OFF touch in an emergency.

Auto Shutdown

An additional safety feature of the cooktop is the auto shutdown. This occurs when you forget to switch off a cooking zone. The default cooking shut down times are shown in the table below:

Power level	1-6	7-10	11-14
Default working time (hour)	8	4	2

USING THE TIMER

There is a timer built into the cooktop. This timer does not control the oven. There are two ways to use the timer:

1. You can use it as a minute minder - the timer does not switch off any cooking zone when the time is up.
2. You can use it as a cut off timer to turn one or more cooking zones off when the time is up.

You can set the timer up to 99 minutes.

Using the timer as a minute minder

Make sure the hob is turned on, and no cooking zone has been activated.

NOTE: you can set the minute minder while the cooking zone is on as long as the power level indicator is not flashing.



Touch the timer key (1) and "05" will show in the timer display and single digit "5" flashes.

Set the desired minutes by touching the slide control. Touch the timer key again and then the number to represent tens digit will flash. Set the desired tens of minutes by touching the slide control.

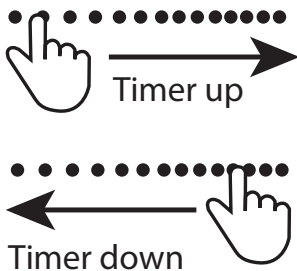

When the time is set it will commence counting down immediately. The display will show the remaining time. A signal will beep for 10 seconds and the timer indicator will show "_ _ " when the set time is finished.

Setting the timer to turn off one or more cooking zones

1. If the timer is set on one zone:

Touch the indicator to choose the cooking zone that you want to set the off timer for.

Touch the timer key (1) and "05" will show in the timer display and single digit "5" flashes.

Set the desired minutes by touching the slide control. Touch the timer key again and then the number to represent tens digit will flash. Set the desired tens of minutes by touching the slide control.

NOTE: The red dot will appear next to the power level indicator of the zone that is in timer mode.

When the set time expires the selected zone will switch off automatically. Other zones will continue to operate if they were turned on previously.

2. If the timer is set on more than one zone

When you set the time for multiple cooking zones a dot shows against the zones under timer control. The minute displays the remaining time of the zone where the dot is flashing on and off.

Once the time expires the corresponding zone will switch off. Then it will show the remaining time on the other zone and dot will flash against that zone.

Cancelling the timer

Select the zone where you want to cancel the timer. Touch the timer key (1) and the indicator will flash. Set the timer to "00" and the timer will be switched off.

PAUSE FUNCTION



The pause function is to stop all heating but to keep all the settings you have set in case you have to interrupt your cooking. You can easily revert all settings using the pause function.

To use the Pause Function

Touch the pause function key (6) and all the heating zones will stop working and all zone displays show II

To cancel the Pause Function

Touch the pause function key (6) and all heating zones will revert to their previous setting.

NOTE: The pause function is available when one or more zones are working. If you don't stop the Pause function then after 30 minutes the cooktop will automatically switch off.

KEEP WARM FUNCTION



The warming function is used to keep cooked food warm. It can also be used as a melting or simmer function.

To enter the keep warm mode touch the cooking zone indicator you want to use and press key (3) to start the keep warm function.

Wait for a moment and the display will show an indicator that the zone is under keep warm mode.

To exit the keep warm mode touch the zone indicator to choose the zone you wish to cancel and then press key (3) to cancel the keep warm function.

INDUCTION POWER LEVEL - ECO SYSTEM 80cm and 90cm wide cookers

Oven Nominal Power: 2500 W - Cooktop Nominal Power: 7400 W

Your induction cooktop is designed to use less electricity. This helps reduce the cost of installing it because it doesn't need heavy wiring. It also leaves more power available for other things in your home, like appliances or an electric car. E Line cookers are very efficient because they share power smartly between the cooktop and the oven, using less energy than most similar products.

GET TO KNOW YOUR COOKTOP - it is a bit quirky but it is great. There are choices on how best to use the cooktop to suit your cooking requirements. Get to know your cooktop and the characteristics of each zone.

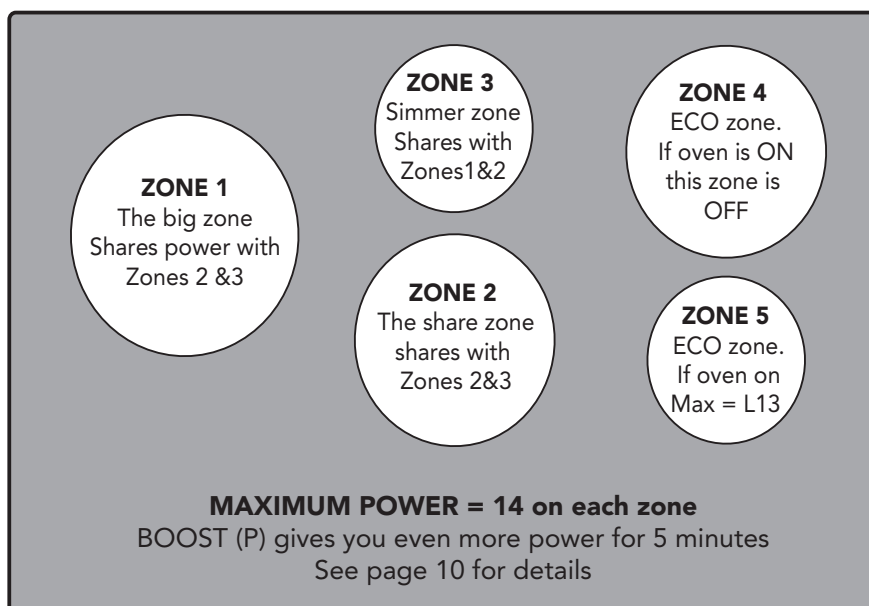

OVEN OFF - Cooktop power choices

1. You can cook using **4 zones only on maximum power** at the same time.
2. You can cook using **5 zones with automatic power sharing** where the levels automatically set to those levels below. These levels are interchangeable.

ZONE 1	ZONE 2	ZONE 3	ZONE 4	ZONE 5
L7	L10	MAX	MAX	MAX
L8	MAX	L7	MAX	MAX

OVEN ON - Cooktop power choices

1. You can cook using **3 zones only on maximum power** at the same time. As per table below.

ZONE 1	ZONE 2	ZONE 3	ZONE 4 Never on with the oven	ZONE 5 Max=13 with the oven on
MAX	MAX	OFF	OFF	L13
MAX	OFF	MAX	OFF	L13
OFF	MAX	MAX	OFF	L13

2. You can cook using **4 zones with automatic power sharing** where the levels automatically set to those levels below. These levels are interchangeable.

ZONE 1	ZONE 2	ZONE 3	ZONE 4	ZONE 5
L8	MAX	L7	OFF	L13
MAX	L7	L10	OFF	L13

UNDERSTANDING THE POWER LEVELS

Power Level		Cooking type	Best purpose for each power level
Max power	Boost	Heat quickly	Ideal to quickly increase the temperature of food up to fast boiling in the case of water or quickly heat cooking liquids
	13-14	Fry - boil	Ideal for browning, starting to cook, frying frozen products, boiling rapidly
High power	11-12	Brown - fry - boil - grill	Ideal for frying, keeping the boil, cooking and grilling (for short times, 5-10 minutes)
	9-10	Brown - cook - stew - fry - grill	Ideal for frying, maintaining a simmer, cooking and grilling (for average times, 10-20 minutes), preheating accessories
Medium power	7-8	Cook - stew - fry - grill	Ideal for stewing, maintaining a light boil, cooking (for longer times). Stir pasta
	5-6	Cook - simmer - thicken - stir	Ideal for slow cooking (rice, sauces, roasts, fish) in the presence of liquid (e.g. water, wine, broth, milk), stirring
	3-4	Cook - simmer - thicken - stir	Ideal for slow cooking (volume less than one litre: rice, sauces, roasts, fish) in the presence of liquid (e.g.
Lower power	1-2	Melt - thaw - keep warm - stir	Ideal for softening butter, gently melting chocolate, thawing small quantities
	1	Melt - thaw - keep warm - stir	Ideal for keeping small portions of freshly cooked food warm or keeping the temperature of serving dishes and
No power	Zero	Support surface	Hob in stand-by or off (possible presence of residual heat from the end of cooking, signalled by H)

SUGGESTED COOKING TASKS FOR POWER LEVEL

Category of food	Dishes or type of cooking	Power level and cookig pattern			
		First stage	Power	Second stage	Power
Pasta, rice	Fresh pasta	Heating water	Booster-14	Cooking pasta and maintaining the boil	7-8
	Boiled rice	Heating water	Booster-14	Cooking pasta and maintaining the boil	7-8
	Risotto	Frying and roasting	7- 8	Cooking	5-6
Vegetables, legumes	Boiled	Heating water	9	Boiling	6-7
	Fried	Heating oil	7- 8	Frying	8-9
	Sauté	Heating accessory	7- 8	Cooking	6-7
	Stewed	Heating accessory	7- 8	Cooking	3-4
	Fried	Heating accessory	7- 8	Browning fried	7-8
Meats	Roast	Browning with oil (if with butter, power 6)	7- 8	Cooking	3-4
	Grilled	Pre-heating pan	7- 8	Grilling on both sides	7-8
	Browning	Browning with oil (if with butter, power 6)	7- 8	Cooking	4-5
	Stew	Browning with oil (if with butter, power 6)	7- 8	Cooking	3-4
Fish	Grilled	Pre-heating pan	7- 8	Cooking	7-8
	Stew	Browning with oil (if with butter, power 6)	7- 8	Cooking	3-4
	Fried	Heating oil or fat	8- 9	Frying	7-8
Eggs	Omelettes	Heating pan with butter or fat	6	Cooking	6-7
	Soft boiled / boiled	Heating water	Booster-14	Cooking	5-6
	Pancakes	Heating pan with butter	6	Cooking	6-7
Sauces	Tomato	Browning with oil (if with butter, power 6)	6-7	Cooking	3-4
	Meat sauce	Browning with oil (if with butter, power 6)	6-7	Cooking	3-4
	Béchamel	Preparing the base (melt butter and flour)	5-6	Bring to simmering point	3-4
Desserts, creams	Custard	Boil the milk	4-5	Keep simmering	4-5
	Puddings	Boil the milk	4-5	Keep simmering	2-3
	Rice pudding	Heat the milk	5-6	Keep simmering	2-3
			13		

INDUCTION COOKTOP CARE AND CLEANING

What?	How?
Dirty stuff on glass (fingerprints, marks, residual stains, or non-sugary spill overs onto the glass).	<ol style="list-style-type: none"> 1. Switch off the power to the hob. 2. Apply a hob cleaner while the glass is still warm (but not hot!) 3. Rinse and wipe dry with a clean cloth or paper towel. 4. Switch the power to the hob back on.
Boil overs, melts, and hot sugary spills on the glass	<p>Remove these immediately with a razor blade scraper suitable for ceramic glass hobs but beware of hot cooking zone surfaces.</p> <ol style="list-style-type: none"> 1. Switch the power to the hob off at the wall. 2. Hold the blade at a 30° angle and scrape the spill to a cool area of the cooktop. 3. Clean the spill up with a dish cloth or paper towel.
Spill overs on the touch controls	<ol style="list-style-type: none"> 1. Switch off the power to the hob. 2. Remove the spill overs 3. Wipe the touch control area with a clean damp sponge or cloth, then dry with a paper towel. 4. Switch the power to the hob back on.

Important!

- When the hob is switched off, there will be no 'hot surface' indication, but the cooking zone may still be hot! Take extreme care!
- Heavy-duty scourers, some nylon scourers and harsh/abrasive cleaning agents may scratch the glass. Read the label to check that your cleaner or scourer is suitable. If in doubt don't use it.
- Never leave cleaning residue on the hob or the glass may become stained.

INDUCTION COOKTOP Questions and quick check reference

Problem	Possible causes and What to do
The cooktop wont turn on.	<p>No power.</p> <ol style="list-style-type: none"> 1. Check the connection to the power supply and make sure it is switched on. 2. Check whether there is a power outage in your home or area. 3. If you've checked everything and the problem persists, call a qualified technician.
The touch controls are unresponsive.	<p>The control panel is locked by the child lock function. Unlock the controls. See section 'Using your cooktop' for instructions.</p>
The touch controls are difficult to operate.	<p>There may be a slight film of water over the controls, or you may be using the tip of your finger when touching the controls. Make sure the touch control area is dry and use the ball of your finger when touching the controls.</p>
The glass is being scratched.	<p>Rough-edged cookware. Unsuitable, abrasive scourer or cleaning products being used. Use cookware with flat and smooth bases. See 'Choosing the right cookware'. See 'Care and cleaning'.</p>
Some pans make crackling or clicking noises.	<p>This may be caused by the material of your cookware (layers of different metals vibrating differently). This is normal for cookware and does not indicate a fault.</p>
The induction hob makes a low humming noise at some certain power setting.	<p>This is caused by the technology of induction cooking. This is normal, but the noise may quiet down or disappear completely when you change the power level setting.</p>
Fan noise coming from the induction hob.	<p>A cooling fan is built in your induction hob which prevents the electronics from overheating. It may continue to run even after you've turned the induction hob off. This is normal and needs no action. Do not switch the power to the induction hob off at the wall while the fan is running.</p>
Pans do not become hot and appears in the display.	<p>The induction hob cannot detect the pan. Check the pan base size, if it is too small for the cooking zone or not properly centred. Use cookware suitable for induction cooking. See section 'Choosing the right cookware'. Centre the pan and make sure that its base matches the size of the cooking zone.</p>
The cooktop or a zone turns itself off unexpectedly. A tone sounds and error code is displayed.	<p>Technical fault. Please note down the error code (typically alternating with one or two digits in the cooking timer display), switch the power to the induction hob off at the wall, and contact a qualified technician.</p>

Cooktop Error Codes

If an abnormality comes up, the hob will automatically enter a protective state and display corresponding protective codes:

Error Codes for Induction Cooktop

Problem	Possible causes	What to do
E1	Signal lost (PCB failure)	Please contact after sales service.
E2/E3	Abnormal high/ Low input voltage	Stop cooking and wait until input voltage back to normal. If not, please contact service centre.
E4/E5/E6	Thermistor failure.	Please contact service centre to repair.
E7	Abnormal high temperature (dry burning)	Cut off power, wait for 30min and switch on. If still not working, please contact service.
E8/E9	Failure of IGBT sensor	Please contact service centre to repair.
E0	IGBT Overheat	Check if the fan is still working. If not, please contact service centre to repair.
EE	Display PCB failure.	Please contact service centre.

The above are the judgment and inspection of common failures.

ATTENTION!

To avoid danger, please do not disassemble the unit by yourself!

NEW COOKER SMELLS

Before cooking in a new cooker, it is important to remove the protective oils that are used during manufacture.

Make sure the room is well ventilated, open a window and run the grill for 20 minutes and operate the oven on 180C for an hour.

USING THE ELECTRIC OVEN

Your cooker is equipped with a multifunction electric oven. To obtain the full benefit of this oven follow these procedures when baking.

1. Remove the grill tray.
2. Choose a function using the selector knob for oven functions. Turn the knob to the symbol of the cooking function you wish to use in your cooking.
3. Rotate the thermostat knob to the desired temperature.
4. Wait for the oven to preheat. The thermostat indicator light goes off to indicate that the oven has reached temperature, and you can introduce the food to be cooked.

Selecting the best oven function

All ovens operate differently and trial and error is part of gaining full familiarity with any new oven. Fan forced is great heat up function and very good when cooking on multiple shelves. The classic bake which applies heat from the top and bottom of the oven works well when cooking on a single level.



Oven Light

The oven light illuminates the oven cavity enabling the user to visually monitor the cooking process.



Fan Forced

The air is forced through the circular element for rapid heat up. In some cooking tasks the food may need to be rotated.



Classic Baking

Uses a top element and a bottom element. It is good function for pizza and cooking on a single shelf. No air movement in the oven.



Bottom Heat

Heat from the bottom element and distributed by a fan. Too slow for initial heat up. Good for browning the bases of pies and pastries.



Double grill with fan

The grill element radiates heat to the top of the food & a fan distributes the heat. Ideal for thicker cuts of meat. Preheat for 3 minutes.



Double grill

Traditional grilling of sausages, chops, cheese toasties. Grilling is done with the door closed for maximum efficiency.



Grill

The single grill element produces radiant heat over a smaller area. Smaller amounts of food can be grilled without wasting energy.



Defrost

The oven fan operates moving the air in the oven cavity. This reduces the amount of time it takes to defrost food.

USING THE OVEN cont.

Thermostat Indicator light

The thermostat indicator light switches on and off during cooking to show that the heating cycles are taking place properly. For static and fan forced mode, the oven must always be preheated.

Try to open the oven door as little as possible as opening the door lowers the temperature and affects the thermostat cycles. When cooking on different shelves simultaneously, put all containers in the centre of the shelves.

USING THE OVEN TIMER

The oven on your cooker is equipped with a touch programmer which has the capability of operating as:

Minute minder - once the desired time is set the timer will start counting down until the time is up and a tone will sound.

Automatic End Cooking - when the time is up the oven will switch off and a tone will sound.

Delayed start - by setting the cooking time and the switch off time the oven will start and stop automatically.

Touch Pad Lock

The timer control touch pad automatically locks after 7 seconds of inactivity. To unlock, press any key for 2 seconds.

Setting the time of day

Press the + and - keys at the same time until the central cursor between the hours and minutes starts flashing. Then press either the + or the - to set the time of day. Once you set the time do not press anything and after a few seconds a beep will confirm the set time.

Setting the countdown timer (Minute Minder)

The minute minder operates independently from the oven and can be used on all oven functions. Press the Menu key until the screen changes. Release the key and adjust the time (minutes) by using the + and - keys. Once you reach the required time, release the key and wait for the confirmation beep.

A bell icon will appear on the screen. At the end of the set time, the bell will ring. Press any key to turn it off. To remove the "A" icon from the screen, press the "Menu" key.

To check the remaining amount of time (before it expires), hold the "Menu" key down.

To delete the set amount of time, press the "Menu" key until the screen changes, and then press the + and - keys at the same time. The set amount of time will thus be deleted.

Setting Auto Power Off

Turn the oven on by adjusting features and temperatures. Hold the "Menu" key down until the screen changes, then press it again. The letters "DUR" (for 'duration') will appear on the screen. Press the + and - keys to adjust the cooking time. Wait for the confirmation beep without touching any keys. When the set amount of time is over, the oven will switch off and a beeping sound will be heard. Press any key to turn it off.

To remove the "A" icon from the screen, press the "Menu" key. To check the remaining amount of time (before it is over) hold the "Menu" key down.

To delete the set amount of time, press the "Menu" key until the screen changes, and then press the + and - keys at the same time. Accordingly, the set amount of times will be deleted. At the end of cooking, remember to place the knob back to the "0" position.

Setting delayed start

Hold the "Menu" key down until the screen changes, then press it again. The letters "DUR" (for 'duration') will appear on the screen. Press the + and - keys to adjust the cooking time. Then press the "Menu" key once and the letters END will appear on the screen, indicating the menu to set the switch-off time. Press the + and - keys to adjust the switch-off time. Then select the cooking feature and required temperature. Obviously, the oven will not start up immediately. Once the set amount of time has passed, the oven will switch off and the beep sound will start. Press any key to turn it off. To remove the "A" icon from the screen, press the "Menu" key.

Setting the volume of the beep

Press + and - at the same time, followed by "Menu", to enter the tone setting mode and press the - key repeatedly to change the tone of the alarm. Once you have selected the tone, the timer will memorize your selection until you wish to change it again.

Practical tips when using the programmer: please consider the amount of time for pre heating the oven when the cooking time is being set. Please switch the oven off at the end of the cooking cycle.

SUGGESTED SHELF POSITIONS - TEMPERATURES & COOKING TIMES

Dish	Shelf Position (1 = Top)		Temperature Degrees C		Cooking Time Minutes
	Static	Fan oven	Static	Fan oven	
Cakes					
Chocolate Cake	2	2 3	180 - 190	180	35 - 40
Cream Caramel	3	2 3	130 - 150	130	30 - 35
Cup Cakes	1	1 2	190 - 200	180 - 190	18 - 20 (35 cakes)
Fruit Cake	3	2 3	175 - 190	165 - 180	35 - 45
Jam Tarts	2	2 3	185 - 200	185 - 200	40 - 50
Nut Cake	3	2 3	190 - 200	180 - 190	40 - 45
Scones	1	1 2	190 - 230	180 - 190	17 (35 scones)
Sponge Cake	2	2 3	195 - 210	185	35 - 45
Swiss Roll	2	2 3	195 - 200	185 - 200	35 - 45
Pastries					
Brioches	3	2 3	190 - 200	180 - 190	25 - 30
Cookies	2	2	180	165	20
Pastry	3	2 3	220 - 240	190 - 220	18
Puff Pastry	3	2 3	230 - 250	200 - 230	10 - 15
Pizza and Bread					
Bread	3	3	235 - 250	215 - 230	40 - 50
Muffins	3	2	205 - 220	185 - 200	25 - 35
Pizza	2	2	215 - 230	195 - 210	20 - 30
Baked Pasta					
Lasagne	2	2 3	185 - 200	165 - 180	30 - 40
Macaroni	2	2 3	225 - 240	205 - 200	35 - 45
Pasta Bake	2	2 3	225 - 240	205 - 200	35 - 45
Vegetable Bake	2	2 3	185 - 200	165 - 180	30 - 40
Baked in foil	2	1 2 3	215 - 230	195 - 210	20 - 25
Fillets or Steak	2	1 2 3	175 - 190	155 - 170	15 - 20
Roast	2	1 2 3	195 - 210	175 - 190	25 - 30
Stewed Fish	2	1 2 3	180 - 190	165 - 180	15 - 20
Roast Meats					
Beef 1kg	3	2 3 4	220 - 250	200 - 220	50 - 60
Lamb 1kg	3	2 3 4	190 - 220	180 - 200	50 - 60
Pork 1kg	3	2 3 4	190 - 220	180 - 200	60 - 80
Veal 1kg	3	2 3 4	190 - 220	180 - 200	60 - 80
Roast Poultry					
Chicken	3	2 3 4	205 - 215	195 - 210	40
Duck	3	2 3 4	210 - 220	195 - 210	120 - 180
Goose	3	2 3 4	210 - 220	195 - 210	120
Turkey	3	2 3 4	215 - 230	195 - 210	220
Roast Game					
Rabbit	3	2 3 4	215 - 235	200 - 220	40
Deer	3	2 3 4	90 - 220	180 - 200	50 - 60
Pheasant	3	2 3 4	205 - 215	195 - 210	40 - 50

OVEN OPERATION NOTES

The cooking information provided is intended purely as a guideline. Modify them to suit your experience, eating habits and personal taste.

The times indicated in the table do not include the preheating of the oven, which is always recommended. The times and temperature indicated refer to average quantities of food - meats = 1/1.5kg; dough for confectionary, pizza, bread = 0.5/0.8kg.

Information in brackets with regards to shelves indicates the shelf to use when cooking several dishes together. All ovens are different, and experimentation and use of the various cooking functions will determine the most effective way to use the oven to suit your cooking style. When cooking on different shelves simultaneously put all containers in the centre of the shelves.

Baking trouble shooting

Problem	Cause	Solution
Cooking Unevenly	Wrong location in oven Wrong size tray Heat variations in oven	Place food in the centre of the oven. Try alternatives Rotate food during cooking
Burning on Top	Oven not preheated Oversized baking tins Food too close to the top of the oven	Wait for oven to reach temperature first Use correct sized tins Place in the centre of the oven
Burning on Bottom	Temperature is set too high Baking tins too large or dark in colour Food too low in the oven Oven door being opened too often.	Reduce the temperature setting Use correct sized silver colour tins
Meat and potatoes not browning	Poor heat distribution on the food	Place the food onto a wire rack in the pan to allow for heat to surround the food
Cakes have a hard split crust and seem over cooked	Temperature set too high Food position too high in the oven Cake tin is too deep Cake tin is dark in colour	Reduce the cooking temperature Cook on a lower shelf height Change to a correct size tin Change to a silver colour tin
Cakes sunk in middle and seem under cooked	Temperature set too low Baking time too short Door was opened too early	Increase the temperature Increase the cooking time Do not open the door until late in the cycle

AIR FRYER BASKET

A standard inclusion with some 90cm models is a stainless steel air fryer basket. The basket uses the movement of hot air in the oven to distribute even heat around the food being cooked.

Select the fan forced function on the electric oven

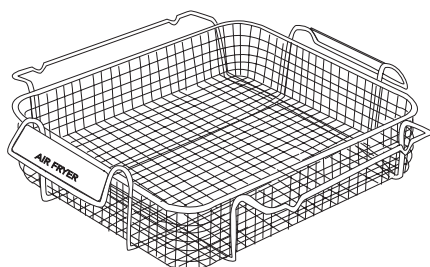

The air fryer basket cooks any frozen food such as oven fries or fish fillets perfectly. Cook following the normal directions on the packet.

Rather than turning the food while cooking just give the basket a shake part way through the cycle. Use the middle shelf and place the grill tray on the shelf below to catch crumbs. Use oven mits to handle the basket as it becomes hot.

Experiment with other foods such as fresh vegetables and try filling the grill tray with water to add steam.

ELECTRIC GRILLING

Your cooker has an electric grill within the oven compartment.

The oven door must be closed during grill operation. If the oven has been on, always wait a few minutes before switching on the grill. The grill element is an infrared type, which provides an even controlled heat. When the grill is on an indicator light will come on.

TIP: Using an oven shelf with a drip tray below filled with some water will avoid smoke build-up coming from burnt fat and at the same time assist to keep the food moist.

The grill function is selected on the oven function selector knob.

Select the temperature of the grill using the temperature selection control knob. Preheat the grill for 3 minutes prior to introducing the food.

Never leave the kitchen when grilling as the cooking is fast and needs to be monitored. There is an override sensor that shuts the grill off in the event of a flare up during cooking.

Selecting the right baking dish

Black baking dishes transfer heat differently to silver baking dishes. If you are burning the under side of cakes and biscuits try changing the colour of baking tray to silver.

COOKER CLEANING AND MAINTENANCE

Do not use strong detergents to clean your cooker. Many detergents or cleaning products will mark stainless steel. The oven and hob must be kept clean, as a buildup of fat constitutes a fire risk. A really great tip is to wipe the oven down with something like a baby wipe each time you cook, and the oven will rarely need a major clean.

Every 3 to 4 years your cooker should be thoroughly checked by an authorised service technician.

1. Cleaning of Stainless Steel:

In order that your cooker retains its new appearance, care should be taken to protect the stainless steel finish. Never use gritty or abrasive sponges. We recommend stainless steel cleaners. Stubborn residues can be removed by soaking in hot water. Stains can be prevented by using a clean cloth soaked in warm water before a spillage becomes cold or dries up. Acid materials like milks, vinegar, citrus juice can damage the most resistant surfaces. If a spill occurs wipe it up immediately.

2. Oven Cleaning:

Oven spills should be cleaned straight away. Leaving spills can also cause permanent damage to the enamel and make it extremely hard to remove later. A non-caustic oven cleaner is recommended such as non-caustic "Mr. Muscle" to clean the the oven only. Do not use abrasive scourers, sponges or cleaning products. Wipe the oven out regularly while the oven is still warm using hot soapy water and a soft cloth or even a baby wipe. The removal of side shelves supports makes cleaning easier.

3. Knobs and Control Panel:

All knobs are removable. Clean behind the knobs and the control panel to prevent grease and grime build up that can cause jamming of the knobs/gas taps etc. The stainless steel panel should be cleaned with a damp cloth, do not use anything abrasive.

4. Cleaning the Oven Door:

The outer glass should be cleaned with a specific glass and mirror cleaner. Soapy water will work to remove stains but may leave streaks. Do not use abrasive or aggressive cleaners on aluminium door frame components, if in doubt contact Glem Gas for advice.

5. Removal of Side Shelf Supports - All models:

The sides racks are removed by simply flexing the bottom rail off the support and unhooking at the top. To replace just reverse the procedure.

6. Grill Element/Top Element -

This element must never be sprayed with any detergents. A damp cloth and a bottle brush can be used to clean the roof of the oven and the element itself. Never soak the element and always dry it after cleaning as not doing so can lead to deterioration. It is important to clean this area regularly as fats spit up and stick to the ceiling and element while grilling and they may burn, smoke and give out unpleasant odors.

RANGEHOODS

Rangehoods and overhead exhaust fans must be installed according to manufacturers' instructions. Rangehoods should be installed not lower than 550mm above the cooktop. Minimum Clearances

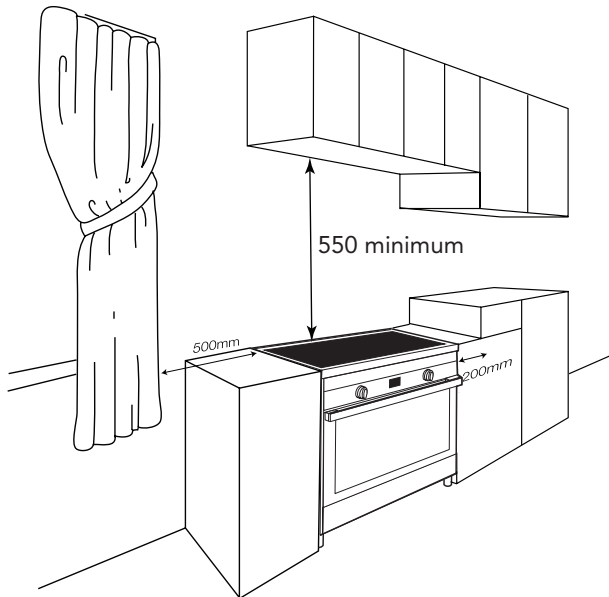

When the upright cooker is installed abutting a side or rear wall, the wall must be of non-combustible material, eg ceramic tiles. The following minimum clearances to combustible materials must be observed:

MINIMUM CLEARANCE FROM COOKTOP TO SIDE WALL MUST BE 200mm

KITCHEN CABINET WARNING

IF THE INCORRECT CABINET MATERIAL IS USED, OR THE DESCRIBED CLEARANCES NOT COMPLIED WITH DURING INSTALLATION THEN THE CABINETS MAY BE DAMAGED DUE TO HEAT TRANSFER FROM THE COOKER.

THE COOKERS ARE MADE TO MEET AUSTRALIAN STANDARDS FOR HEAT TRANSFER AND SURFACE TEMPERATURES.

ALL ADJACENT SURFACES TO THE COOKER MUST BE ABLE TO WITHSTAND NORMAL HEAT TRANSFER FROM THE COOKER, AND THE HEAT RELEASED FROM THE OVEN DOOR WHEN OPENED.

GLEM GAS ACCEPTS NO RESPONSIBILITY FOR CABINET DAMAGE FOR DAMAGE TO KITCHEN CUPBOARDS AND DRAWERS DUE TO INCORRECT INSTALLATION.

IF IN DOUBT INSTALL A HEAT SHIELD SUCH AS A THIN SHEET OF FIBROUS CEMENT BETWEEN THE COOKER AND THE CUPBOARDS.

OVERALL DIMENSIONS OF THE COOKER

Depth over cabinet 600 mm - all models
Height over cooktop is either 760 mm or 750 mm (check model)
Height over splashback is either 810 mm or 820 mm (check model)

Width of cooker models:

86 series width 798 mm
96 series width 898 mm

Height of legs must be added to the overall cooker dimensions

Height adjustable legs add up to 160 mm on 60, 70, 80 and 90 cm cookers.

REFER TO RELEVANT PAGE IN THIS MANUAL FOR INSTALLATION OF ANTI TILT BRACKETS

NOTE: Glem Gas Australasia Pty Ltd and their appointed agents decline any responsibility in the case of an installation not according to these instructions.

INSTALLATION INSTRUCTIONS -

Licensed qualified installers only

These instructions are for the use of a qualified installer only! It is the owner's responsibility to ensure that the installer is correctly licensed to complete installation. Faulty installations will not be serviced, and you may be subject to a call out fee if the cooker is found to be incorrectly installed.

Statutory regulations

This appliance is to be installed in accordance with the manufacturer's installation instructions, applicable building codes and electrical wiring regulations. Consult SAA wiring rules as appropriate.

Safety Warnings About Installation

- The cooker must be installed and serviced by a qualified technician.
- A certificate of compliance must be supplied by the installer and kept by the customer.
- All packaging materials including protective plastic film must be removed before the cooker is installed.
- The anti-tilt brackets must be fitted.
- The cooker must not be lifted or pulled using the oven handle.
- The cooker must be serviced and checked at least every 3 to 4 years depending on usage and condition.

ELECTRICAL CONNECTION

The power supply should be connected in compliance with the relevant standard, or a single-pole circuit breaker. The appliance can work in the following modes:

1. Single phase connection 220-240V 1N

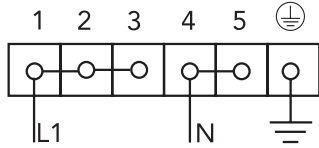

Three core cable requirements:

80cm & 90cm cookers power cable size: 3 x 6 sq mm

60cm & 70cm cookers power cable size: 3 x 10 sq mm

Note: These power cables are sized taking into account the coincidence factor (in compliance with standard EN 60335-2-6).

2. Two phase connection 380-415V 2N

(a) Power cables size: 4 x 4 sq mm (four-core cable)

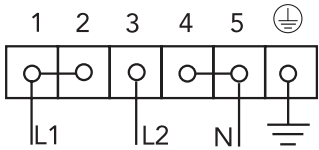

(b) Power cables size: 4 x 4 sq mm (four-core cable)

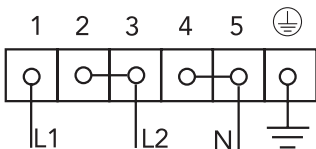

3. Three phase connection 380-415V 3N

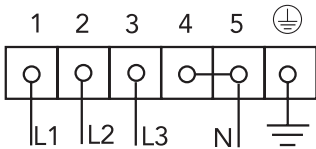

Power cables size: 5 x 2.5 sq mm (five-core cable)

Connecting to services and commissioning

This appliance must be installed to the mains power supply only by a qualified electrician who is familiar with and adheres to the local requirements and supplementary regulations of your electricity supplier. Do not carry out the installation yourself.

RISK OF ELECTRIC SHOCK.

This appliance must be installed according to all codes and regulations of:

- Electrical supply authorities;
- Building regulations;
- Local government and council authorities;
- AS/NZS 3000.

Before connecting the hob to the mains power supply, check that:

- The domestic wiring system is suitable for the power drawn by the hob.
- The voltage corresponds to the value given in the rating plate
- The power supply cable sections can withstand the load specified on the rating plate.

Hard wiring detail

1. Remove the terminal block access panel at the rear of the cooker.
2. Make connections to terminals, using K1 jumpers to configure the right connections (see below).
3. Engage wires into retaining clip. Secure the retaining clip with the screw.
4. Replace the rear access panel.

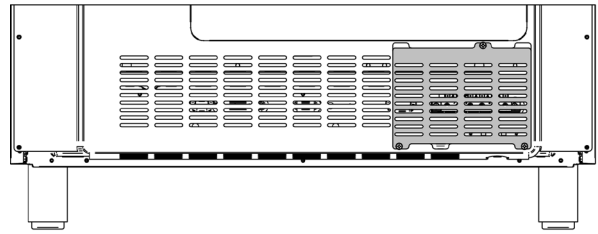

1

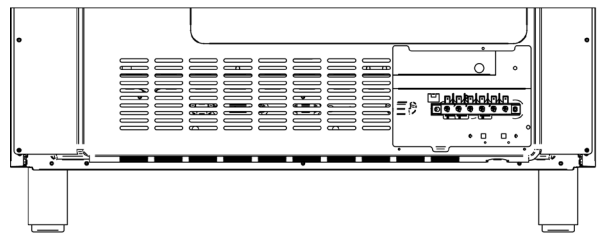

2

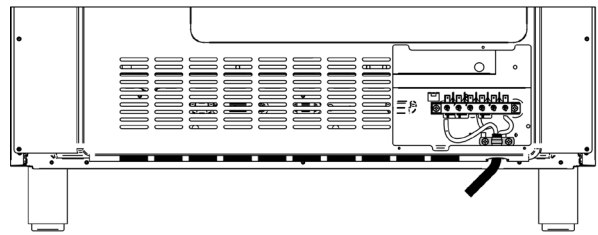

3

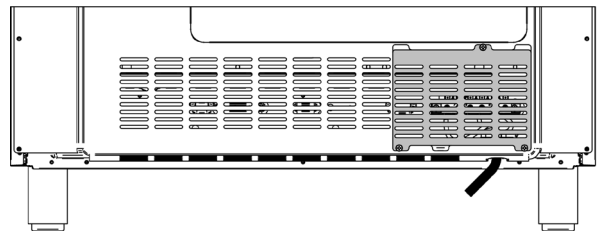

4

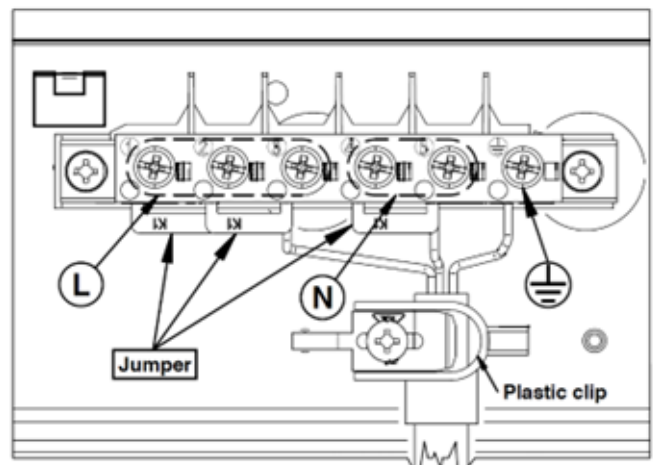

To connect the product to the mains power supply, do not use adapters, reducers, or branching devices, as they can cause overheating and fire.

The power supply cable must not touch any hot parts and must be positioned so that its temperature will not exceed 75°C at any point.

Note - Check with an electrician whether the domestic wiring system is suitable without alterations. Any alterations must only be made by a qualified electrician.

1. If the appliance is being connected directly to the mains supply, an omni-polar circuit breaker must be installed with a minimum gap of 3mm between the contacts.

2. The installer must ensure that the correct electrical connection has been made and that it complies with safety regulations.

3. Your household power supply must meet the power consumption of the appliance.

4. When the socket is not accessible for the user or a fixed electrical connection of the appliance is required, an all-pole disconnecting device must be incorporated during installation. Disconnecting devices are switches with a contact opening distance of at least 3 mm.

These include LS-switches, fuses and protectors (EN 30335). Read the information on the nameplate and the connection diagram before connecting the appliance to the mains. The electricity supply must be performed via a 16A automatic cut-out. If in doubt, always contact the local building authorities and consult the relevant legal provisions.

PRODUCT WARRANTY

Thank you for choosing a Glem Gas or Emilia Appliance. The purchase of this appliance is an important investment in your home and so to protect your investment we urge you to complete the registration card attached, please return it immediately.

The benefits conferred by this warranty are in addition to all other conditions and warranties in respect of this product which the consumer may have under the Trade Practices Act 1874 of the Commonwealth of Australia and/or similar State or Territory Laws.

Our goods come with guarantees that cannot be excluded under the Australian Consumer Law. You are entitled to a replacement or refund for a major failure if the goods fail to be of acceptable quality. You are also entitled to have the goods repaired or replaced if the goods fail to be of acceptable quality and failure does not amount to a major failure.

Glem Gas Australasia Pty Ltd warrants, this appliance to be free from defects in workmanship and materials for a period of:

a) Where the appliance is intended to be used and is used for DOMESTIC USE - 24 MONTHS FROM DATE OF DELIVERY TO THE ORIGINAL PURCHASER.

b) Where the appliance is intended to be used and is used for COMMERCIAL USE - NO WARRANTY APPLIES. THIS IS A DOMESTIC APPLIANCE ONLY.

Glem Gas Australasia Pty Ltd, during the period of warranty, will at its option, and subject to the terms and conditions stated below, repair or replace free of charge this appliance or any component part, which upon examination by Glem Gas Australasia Pty Ltd. is found to be defective.

This Warranty shall not apply:

- a) If the rating plate has been removed or the serial number or other details on it have been removed or rendered illegible.
- b) If the appliance has been subjected to misuse, abuse accident or want of care.
- c) If the appliance has been installed, operated or maintained contrary to the instructions supplied by Glem Gas Australasia Pty Ltd.
- d) If any defect or failure is due to connection to an inadequate or faulty power supply.
- e) If damage is caused by foreign objects in or on the appliance or by reason of its use for purposes other than that for which it was delivered.
- f) If a repair has been made or attempted by the purchaser.
- g) If you live more than 80 kilometres outside the service area of the Glem Gas Australasia service agents, this warranty does not cover the cost of transport of the appliance for service or the service agent’s travelling time.

Light Globes

This warranty does not cover any glass damage or replacement of light bulbs.

Glass doors

This warranty does not cover oven door breakage.

Induction cooktop breakage

This warranty does not cover breakage, cracking or damage of the induction cooktop.

Consequential Damage or Economic Loss

Glem Gas Australasia Pty Ltd accepts no liability pursuant to this Warranty for any cost or consequential damage or economic loss whether direct or indirect, to any person or property, arising from breakdown or failure of this appliance or any part thereof, and no responsibility is to be implied or accepted over and above the replacement value of the product.

Replacement Parts

Parts covered under warranty that need replacing i.e. seals, knobs and burner caps. These can be posted to the customer to put on at their discretion.

This Warranty is given by Glem Gas Australasia Pty Ltd and no other person or organisation is authorised to vary its provisions and conditions.

Complete this section and keep for your own record.

Appliance Type _____

Model No _____

Serial No _____

Purchased From _____

Date of purchase _____

Please complete the section below and return to:
Glem Gas Australasia Pty Ltd, P.O. Box 63 Blaxcell PO
South Granville NSW 2142
or Scan/Photograph and email to info@glemgas.com.au

Cooker Model number _____

Serial number _____

Retailer name and address and date of purchase

Customer’s Details

Name and address

Postcode _____

Email address _____

Tel. number _____

Installer’s Details

Installer’s name _____

Installer’s signature _____

Installer’s License number _____

Installer’s compliance number _____

Installer’s telephone _____

GLEM GAS AUSTRALASIA PTY. LTD.
P.O.Box 63 Blaxcell PO South Granville NSW 2142
Phone: 1 300 307 917
Email info@glemgas.com.au for service
www.glemgas.com.au