

70cm Integrated Refrigerator & Freezer

MODEL AINT7000



*2+3 Years with product registration



PRODUCT INFORMATION

FEATURES

- electronic touch control display
- super cool function
- super freezing function
- ECO function
- holiday function
- door open alarm
- reversible door
- frost free
- safety glass shelves
- full height LED panel illuminates the entire fridge

CAPACITY

- refrigerator: 257L net*
- *incl. fresh zone compartment: 35L net
- freezer: 84L net
- Total net: 341L

TEMPERATURE RANGE

- Fridge: 5°C - 2°C
- Fresh Zone: 3°C - -3°C
- Freezer: -15°C - -25°C

COMPARTMENTS

- 3 freezer drawer compartments
- 4 fridge adjustable shelves
- 1 x vegetable crisper drawer
- 1 x meat storage drawer
- 1 x large door shelf
- 3 x medium door shelves

ACCESSORIES

- 1 x egg tray
- 1 x ice tray

TECHNICAL INFORMATION

- 2m power cord
- max. door weight: 15kgs per door

EAN TBA

AR03092024

DISCLAIMER

Eurolinx & Worldwide appliances Pty Ltd, is continually seeking ways to improve the design specifications, aesthetics and production techniques of its products. As a result alterations to our products and designs take place continually. Whilst every effort is made to produce information and literature that is up to date, this brochure should not be regarded as an infallible guide to the current specifications, nor does it constitute an offer for the sale of any particular product. Product dimensions indicated in our literature is indicative only. Actual product only should be used to define dimension cut outs. Distributors, and retailers are not agents of Eurolinx or Worldwide appliances and are not authorised to bind Eurolinx or Worldwide appliances by any express or implied undertaking or representation.

Australia National Telephone Number 1300 694 583
For showroom opening times, visit our website

artusi.com.au

NSW & ACT (Head Office)
48-50 Moore Street
Leichhardt
F 02 8569 4699

Victoria
2r/131 Church Street
Hawthorn

QLD
Contact Head Office

WA & NT
Contact Head Office

70cm Integrated Refrigerator & Freezer

MODEL AINT7000

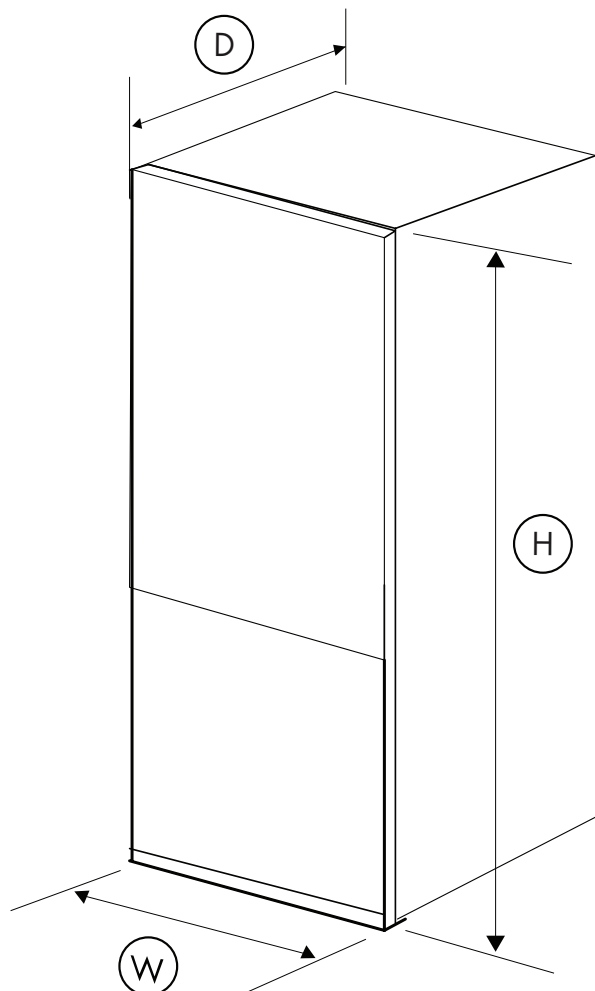

- W 690mm
- H 1937mm
- D 550mm (without panel)

The gap between the top and bottom door panels should be equal to or >4mm, the gap between fridge and freezer doors are 10mm.

NB: drawings are not to scale — for detailed installation instructions, please refer to user guide.

EAN TBA

AR03092024

DISCLAIMER

Eurolinx & Worldwide appliances pty Ltd, is continually seeking ways to improve the design specifications, aesthetics and production techniques of its products. As a result alterations to our products and designs take place continually. Whilst every effort is made to produce information and literature that is up to date, this brochure should not be regarded as an infallible guide to the current specifications, nor does it constitute an offer for the sale of any particular product. Product dimensions indicated in our literature is indicative only. Actual product only should be used to define dimension cut outs. Distributors, and retailers are not agents of Eurolinx or Worldwide appliances and are not authorised to bind Eurolinx or Worldwide appliances by any express or implied undertaking or representation.

FOLLOW US ON:  [/artusi_kitchen_laundry_outdoor](https://www.instagram.com/artusi_kitchen_laundry_outdoor)

Australia National Telephone Number 1300 694 583
For showroom opening times, visit our website

[artusi.com.au](https://www.artusi.com.au)

NSW & ACT (Head Office)
48-50 Moore Street
Leichhardt
F 02 8569 4699

Victoria
2r/131 Church Street
Hawthorn

QLD
Contact Head Office

WA & NT
Contact Head Office