

5.1kW split system reverse cycle air conditioner featuring wireless connectivity, inverter compressor, DC fan motor, Super ion filter & bio filter, 3D air flow, Follow-Me, LED remote, demand response capable. 5.1kW cooling/6.1kW heating capacity.



Product Details

FEATURES

DC Inverter technology	Sleep Mode	HEPA 13 and Cold Catalyst filters	Self Clean function
Turbo Mode	FollowMe	3D Air	Connectivity

BENEFITS

Enjoy a peaceful nights sleep

Sleep Mode is designed to create the ideal sleeping environment, providing you with ultimate comfort and more energy efficiency*. The Sleep Mode feature automatically adjusts the temperature and fan speed to maintain optimal comfort throughout the night gradually increasing or decreasing the temperature as you sleep, preventing excessive cooling or heating and creating a quiet and uninterrupted sleep experience.*Based on Sleep Mode versus Normal Mode operation of Westinghouse air conditioner unit.

Breathe easy filters

Our air conditioners come with two different types of filters to help keep your home cleaner and healthier. The HEPA 13 filters capture up to 99.99% of common harmful bacteria*and the Cold Catalyst filtration helps trap and remove volatile organic compounds (VOCs) and gases**. Plus, they are easy to clean and maintain, ensuring that your air conditioner continues to run to at peak performance. *Tested on Escherichia coli, Staphylococcus aureus and Klebsiella pneumonia. **Tested on Ethyl Mercaptan, Ammonia and Trimethylamine.

Effortless maintenance

With a touch of a button, the self-clean function effortlessly initiates a thorough cleaning cycle that helps remove the build up dirt, mildew and bacteria from the units components. It does this by cleaning the internal mechanisms of the air conditioner to help maintain a healthier environment.

Boost your cooling or heating

Turbo mode activates fast cooling or heating to bring your room to a desired temperature quickly and effectively. Use this on those extra hot or cold days to get comfortable quickly.

DC Inverter Technology

Our advanced DC Inverter technology offers efficient cooling and heating with less energy consumption*. The DC Inverter adjusts the cooling and heating output to meet your desired temperature, providing consistent comfort with less energy waste. *Based on air conditioners with non-DC inverter technology

Comfort controlled

FollowMe adjusts the temperature based on your remotes location, always ensuring youre comfortable, rather than adjusting to a sensor near the ceiling. No more guesswork required to be nice and comfy.

Even air flow in all directions

Our 3D Air circulates air in all directions, from left to right and top to bottom ensuring everyone is in optimal comfort throughout the room. With its advanced technology, the 3D Air feature combined with the HEPA 13 filters creates a more comfortable and healthier living environment, reducing hot and cold spots and improving air quality. Control is in your hands with the ability to turn this feature on and off based on your comfort level.

Control your comfort from anywhere with our +Home app

You'll love the convenience of being connected to control your home's temperature from anywhere, at any time. With the touch of a button on your smartphone, you can adjust the temperature, set schedules, and monitor energy usage from the comfort of your couch or on the go. Our +Home APP* now also integrates with the Google and Amazon voice assistants, for the next level of control at home.*Internet and mobile device required.

Specifications

PRODUCT PROFILE

Domestic warranty details (yrs)	5
---------------------------------	---

Type	reverse cycle
------	---------------

SPECIFICATIONS

Capacity cool watts	5100
---------------------	------

Capacity Heat watts	6100
---------------------	------

Current rating amps	13
---------------------	----

Power Supply Connection Point	outdoor unit
-------------------------------	--------------

Colour of fascia	White
------------------	-------

Compressor type	rotary
-----------------	--------

Indoor sound pressure dBA high setting	45
--	----

Indoor sound pressure dBA low setting	37
---------------------------------------	----

Outdoor sound pressure dBA	59
----------------------------	----

Indoor air circulation max (ltr/s)	500
------------------------------------	-----

Ambient temperature range minimum	-5
-----------------------------------	----

Ambient temperature range maximum	50
-----------------------------------	----

SPECIFICATIONS

Moisture removal ltr/hour	0.41
---------------------------	------

Refrigerant weight (g)	1300
------------------------	------

Refrigerant type	R32
------------------	-----

ZONED ENERGY RATING LABEL (ZERL)

Hot Climate Cooling	4.5 stars
---------------------	-----------

Hot Climate Heating	4 stars
---------------------	---------

Average Climate Cooling	4 stars
-------------------------	---------

Average Climate Heating	3 stars
-------------------------	---------

Cold Climate Cooling	4.5 stars
----------------------	-----------

Cold Climate Heating	2.5 stars
----------------------	-----------

OUTDOOR UNIT DIMENSIONS

Width (mm)	890
------------	-----

Height (mm)	673
-------------	-----

Depth (mm)	342
------------	-----

INDOOR UNIT DIMENSIONS

Total width (mm)	1196
------------------	------

Total height (mm)	370
-------------------	-----

Total depth (mm)	279
------------------	-----

FEATURES

FEATURES

Features - Air Conditioners	anti cold air function,remote control,manual operation,economy or sleep mode,air swing auto up/down,air swing auto left/right,auto restart,room temperature display,fan mode,auto mode,air direction control,Heating Mode,cooling mode,dry mode,self diagnosis,demand-response enabled,low pressure detection,Remote Control Lock,Follow me,Turbo,Sleep mode,Wireless enabled
-----------------------------	---

Filtration	biofresh,hepa,dust,Ion Filter
------------	-------------------------------

Remote control type	back lit,LED
---------------------	--------------

Timer	24 hour
-------	---------

Anti corrosion treatment	gold shield
--------------------------	-------------

Fan speeds	low,medium,high,turbo,Auto,Silent
------------	-----------------------------------

Display/ indicators	temperature,defrost
---------------------	---------------------

INSTALLATION REQUIREMENTS (PIPING AND WIRING)

Gas pipe size	12.7
---------------	------

Liquid pipe size	6.35
------------------	------

INDOOR UNIT PACKED DIMENSIONS

Shipping Volume (m3)	0.21
----------------------	------

Shipping Weight (Kg)	23.4
----------------------	------

INSTALLATION REQUIREMENTS (PIPING AND WIRING)

Maximum piping length vertical (m)	20
------------------------------------	----

Maximum piping length (m)	30
---------------------------	----

Additional refrigerant required supplied charge length (g/m)	12
--	----

Maximum pipe length with supplied charge (m)	5
--	---

Wires connecting indoor unit to outdoor unit	4
--	---

INDOOR UNIT PACKED DIMENSIONS

Pack Dimensions Width (mm)	1280
----------------------------	------

Pack Dimension Height (mm)	455
----------------------------	-----

Pack Dimension Depth (mm)	355
---------------------------	-----

OUTDOOR UNIT PACKED DIMENSIONS

Shipping Volume (m3)	0.3
----------------------	-----

Shipping Weight (Kg)	44.5
----------------------	------

Pack Dimensions Width (mm)	995
----------------------------	-----

Pack Dimension Height (mm)	730
----------------------------	-----

Pack Dimension Depth (mm)	398
---------------------------	-----

Dimensions

Split System Air conditioners

WSD51HWA
WSD73HWA

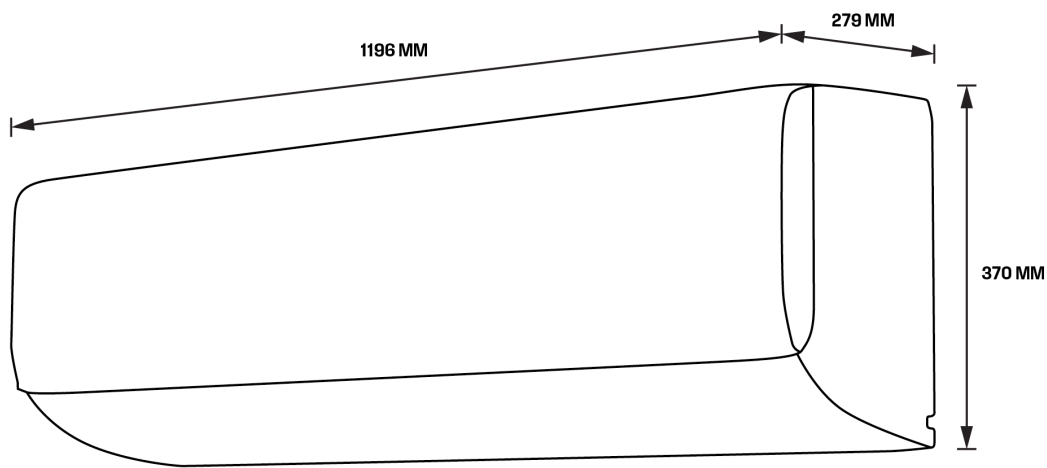

Minimum clearance for installation

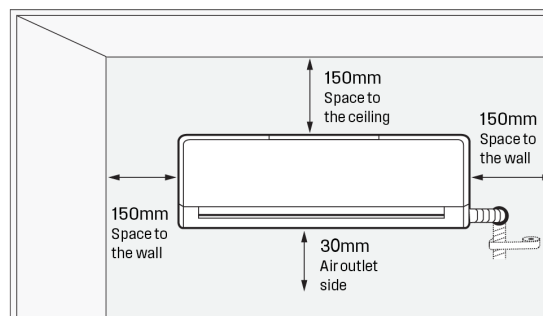

IMPORTANT

These dimensions are a guide only. All measurements are in millimetres (mm). For complete installation instructions, refer to the manual provided with product.

Terms and Conditions

IMPORTANT

This is a guide of product dimensions only. For complete installation instructions, refer to the manual provided with product.

PRODUCT INFORMATION

The descriptors and illustrations in this publication apply to the specific products and models described as at the date of issue. Under our policy of continuous product development, product specifications may change without notice. Prospective purchasers should therefore check with their retailer to ensure this publication correctly describes the products that are being offered for sale. All information supplied is to be used for general reference purposes only and is on the understanding that Electrolux Home Products Pty Ltd (Australia) and Electrolux (NZ) Ltd (New Zealand) will not be liable for any loss, liability or damage of whatever kind arising as a result of reliance on such information. Colours of products illustrated are as close as printing limitations allow. Electrolux will at all times comply with its obligations pursuant to law including Trade Practices (Australian Consumer Law) Act and Regulations.

WARRANTY

This warranty only applies to Appliances purchased and used in Australia or New Zealand and used in normal domestic applications and is in addition to (and does not exclude, restrict, or modify in any way) any non-excludable statutory warranties in Australia or New Zealand. All warranties are subject to the conditions set out in the warranty card accompanying the product when purchased.

ELECTROLUX HOME PRODUCTS AUSTRALIA

telephone: 1300 363 640

fax: 1800 350 067

email: customercare@electrolux.com.au

web: www.electrolux.com.au

ELECTROLUX HOME PRODUCTS NEW ZEALAND

telephone: 09 573 2230

fax: 09 573 2221

email: customercare@electrolux.co.nz

web: www.electrolux.co.nz