



# CROSSWAVE<sup>®</sup> OMNIFORCE<sup>®</sup>

CORDLESS ALL-IN-ONE MULTI-SURFACE CLEANER

MODELS 4325F, 4325H

## QUICK START GUIDE

### 1 Get Ready

Assemble and charge machine (pg 5). If dry cleaning, strainer could be removed for increased tank capacity (pg 6). If wet cleaning, fill the clean water tank (pg 7).

### 2 Choose Your Cleaning Mode

Press **(C)** to power on. Choose mode with **(B)**. View selection on **(D)**. When using both modes in one cleaning session, start with Power Vac Mode for dry cleaning and then switch to Power Mop Mode.



#### Power Vac Mode

Great for dry debris on hard floors and area rugs. Run time up to 45 minutes.



#### Power Mop Mode

Efficiently clean wet and dry messes together. Run time up to 45 minutes.



### 3 Start Cleaning

Recline machine with your foot to start brush roll. For extra fluid and suction, use Turbo Mode **(A)** (up to 18 minutes run time). For dry and wet cleaning against walls and baseboards, use ZeroGap™ Edge Cleaning **(E)**, located on the right side of the foot.

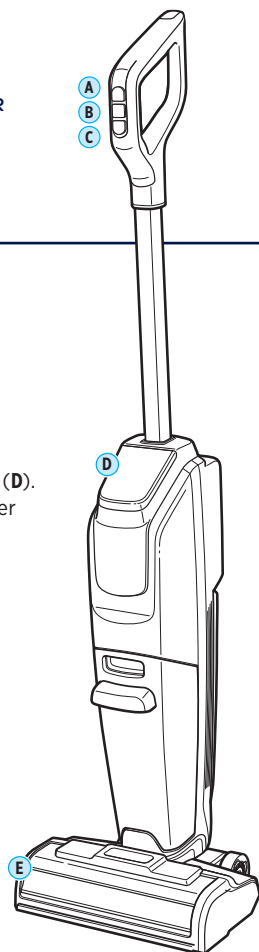

## CLEANING TIPS

- For best results, use on hard floors and large/heavy area rugs. Follow manufacturer's instructions for small/lightweight rugs.
- Tap out the filter after each Power Vac use and wash after 3 uses. Always wash the filter after using Power Mop Mode.
- Ensure battery is fully charged before storing for over 6 months.
- **Scan the QR code for product videos, tips, and support.**



SYMBOL	EXPLANATION
	Caution.
	Read operator's manual.
	Risk of fire.
	Risk of electric shock.
	For indoor use only.
	Do not expose to rain.
	Use only BISSELL® cleaning formulas intended for use with this machine.
	Disconnect power before servicing.
	Protection against moving parts.
	Risk of automatic start-up.
	Always turn unit off prior to charging.
	Detachable power supply unit.
	This symbol on the product and/or accompanying documents means that used electrical and electronic products should not be mixed with general household waste. For proper treatment, recovery and recycling, please take this product to designated collection points. Please contact your local authority for further details of your nearest designated collection point.

SYMBOL	EXPLANATION
	This symbol means to recycle. Do not mix batteries with general household waste. Recycle used batteries at your nearest recycling center.
	Allow parts to dry.
	Use warm water, temperature up to 60°C.
	Check the manufacturer's tag before cleaning textile. "W" on the tag as shown means you can use your cleaner.
	Lock.
	Do not freeze.
	Direct current.
	Suitable for use by children at least 8 years old.
	Recycle Li-Ion battery.
	Corrugated Recycles.
	Warning: Slippery surface.
	Clean out cycle. Automatic self-cleaning cycle after use.
	Corrugated fibreboard.

## IMPORTANT SAFETY INSTRUCTIONS

### READ ALL INSTRUCTIONS BEFORE USING YOUR APPLIANCE.

When using an electrical appliance, basic precautions should be observed, including the following:



### WARNING TO REDUCE THE RISK OF FIRE, ELECTRIC SHOCK OR INJURY:

- This appliance is not intended for use by persons (including children) with reduced physical, sensory or mental capabilities, or lack of experience and knowledge, unless they have been given supervision or instruction concerning use of the appliance by a person responsible for their safety.
- Children should be supervised to ensure that they do not play with the appliance.
- Floor slippery when wet.
- The appliance has to be unplugged after use and before carrying out user maintenance on the appliance.
- Unplug the charger from electrical socket when not in use, before cleaning maintaining or servicing the appliance.
- Read all instructions before using your appliance.
- If the battery charger is damaged, it must not be used until it has been repaired.
- Use indoors only.
- Use only cleaning products intended for use with this appliance to prevent internal component damage. See the Cleaning Formulas section of this guide.
- Do not allow to be used as a toy. Close attention is necessary when used by or near children.
- Do not use for any purpose other than described in this user guide. Use only manufacturer's recommended attachments.

- If the charger supply cable is damaged, it must be replaced by the manufacturer, its service agent or similarly qualified person in order to avoid a hazard.
- Do not pull or carry by cord, use cord as a handle, close door on cord, or pull cord around sharp edges or corners. Do not run appliance over cord. Keep cord away from heated surfaces.
- Do not unplug charger by pulling on cord. To unplug, grasp the plug, not the cord.
- Do not handle charger plug or appliance with wet hands.
- Do not put any object into openings. Do not use with any opening blocked; keep openings free of dust, lint, hair, and anything that may reduce air flow.
- Keep hair, loose clothing, fingers, and all parts of body away from openings and moving parts of the appliance and its accessories.
- Turn OFF all controls before plugging or unplugging charger.
- Use extra care when cleaning on stairs.
- Do not use to pick up flammable or combustible materials (lighter fluid, gasoline, kerosene, etc.) or use in areas where they may be present.
- Do not pick up anything that is burning or smoking, such as cigarettes, matches, or hot ashes.
- Do not use without filters in place.
- Risk of injury from moving parts. brush may start unexpectedly. Unplug before cleaning or servicing.
- Do not turn your appliance ON until you are familiar with all instructions and operating procedures.

- Do not use appliance in an enclosed space filled with vapors given off by oil-based paint, paint thinner, some moth-proofing substances, flammable dust, or other explosive or toxic vapors.
- Do not use to pick up toxic material (chlorine bleach, ammonia, drain cleaner, etc.)
- Plastic film can be dangerous. To avoid danger of suffocation, keep away from children.
- This appliance can be used by children aged from 8 years and above and persons with reduced physical, sensory or mental capabilities or lack of experience and knowledge if they have been given supervision or instruction concerning use of the appliance in a safe way and understand the hazards involved. Children shall not play with the appliance. Cleaning and user maintenance shall not be made by children without supervision.
- CAUTION: Only allow children at least 8 years old to use the battery charger. Give sufficient instruction so that the child is able to use the battery charger in a safe way and explain that it is not a toy and must not be played with. Instruct the child not to try and recharge non-rechargeable batteries because of the danger of eruption.
- Recycle batteries, do not mix with household waste.
- The appliance is only to be used with the power supply unit provided with the appliance.
- For the purposes of recharging the battery, only use the detachable supply unit provided with this appliance.
- Unplug charger from electrical socket when not in use, before cleaning, maintaining or servicing the appliance, and if your appliance has an accessory tool with a moving brush, before connecting or disconnecting the tool.
- This appliance must only be supplied at safety extra low voltage corresponding to the marking on the appliance.
- If appliance is not working as it should, has been dropped, damaged, left outdoors, or dropped into water; do not attempt to operate it and have it repaired at an authorized service center.
- Liquid must not be directed toward equipment containing electrical components.
- Use only the type and amount of liquids specified under the operations section of this guide.
- Do not use non-rechargeable batteries.
- This appliance contains lithium ion type batteries that are non-replaceable.
- Do not charge with damaged charger or plug. If appliance is not working as it should, has been dropped, damaged, left outdoors or dropped into water, have it repaired by a qualified technician.
- Recharge appliance only with the charger specified by the manufacturer. A charger that is suitable for one type of battery pack may create a risk of fire when used with another battery pack.
- Do not expose battery pack or appliance to fire or excessive temperature. Exposure to fire or temperature above 130°C may cause explosion.
- Do not incinerate the appliance even if it is severely damaged. The batteries can explode in a fire.
- Unplug before connecting to docking station.
- Use only with charger SIL, Model SSC-297100AU OR E-TEK, Model ZD024M300100AU.

## **SAVE THESE INSTRUCTIONS**

### **ORIGINAL INSTRUCTIONS.**

**FOR OPERATION ON A 220-240 VOLT A.C. 50-60 HZ POWER SUPPLY ONLY.**

**THIS MODEL IS FOR HOUSEHOLD USE ONLY.**

## **IMPORTANT INFORMATION**



- To reduce the risk of a leaking condition, do not store where freezing may occur. Damage to internal components may result.
- Keep appliance on a level surface.
- If your appliance has a motorised brush roll, do not leave machine running in the same spot without the handle fully upright.
- Plastic tanks are not dishwasher safe. Do not put tanks in dishwasher.

# Table of Contents

CLEANING TIPS.....	1	Clog Detection Feature.....	5
QUICK START GUIDE.....	1	Power Vac Mode.....	6
Important Safety Instructions.....	2	Power Mop Mode.....	7
Product Overview.....	4	After-Cleaning Care.....	10
Assembly & Charging the Battery.....	5	Troubleshooting.....	11

## TOOLS INCLUDED IN BOX WILL DIFFER BY MODEL

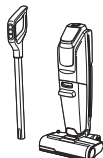
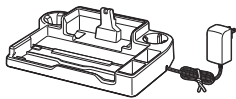
To see what's included with your purchase, check the "Carton Contents" list on the top flap of the box.

		
Handle & Body	3-in-1 docking station	Trial Formula(s)

## Product Overview

### Product Overview

1. Turbo Mode Button
2. Cleaning Mode Button
3. Power On/Off Button
4. Clean-Out Cycle Button
5. Display
6. Dirty Tank
7. Brush Roll Window
8. Clean Water Tank
9. ZeroGap™ Edge Cleaning Technology

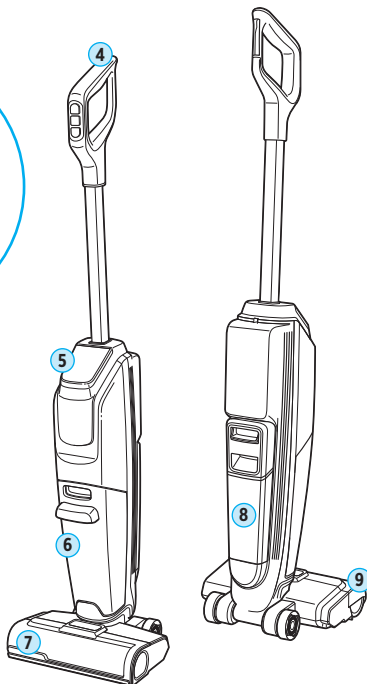
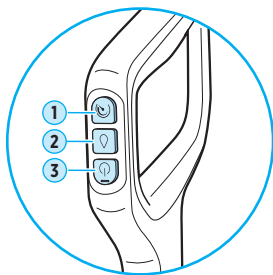

## Display

Note: When machine is docked, screen will be flipped.

1. Dirty Tank Full
2. Error Indicator
3. Charging
4. Low Battery
5. Battery % Remaining
6. Clog Detected
7. Suction Level
8. Fluid Level
9. Brush Roll Stuck
10. Clean-Out Cycle Indicator
11. Clean Tank Empty

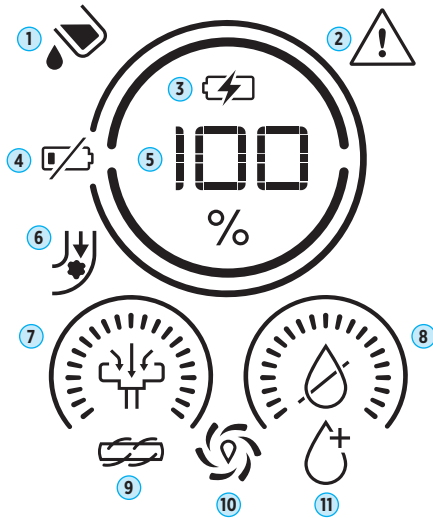

## Assembly & Charging the Battery

Note: To activate, make sure machine is fully charged before first use. If machine has been in storage for over 6 months, charge fully before using.

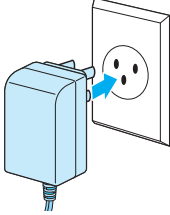
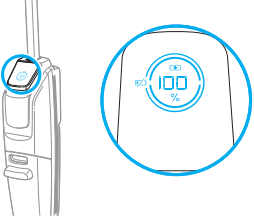
		
<b>1.</b> Firmly insert handle into body of machine until it clicks.	<b>2.</b> Plug charging cable plug into the wall.	<b>3.</b> Place machine on tray and ensure charging icon is lit up. Let charge for 4 hours or until battery reaches 100% charge.

## Clog Detection Feature

1. If a partial clog is detected,  will be displayed on the display. Refer to troubleshooting guide on page 11 for steps to resolve.
2. If a full system clog is detected, the unit will turn off and display the E1 error code. Refer to troubleshooting guide on page 11 for steps to resolve.

**⚠ WARNING** To reduce the risk of fire and electric shock due to internal component damage, use only BISSELL cleaning formula intended for use with this machine.

# Power Vac Mode

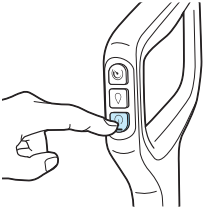

**1.** Press power button to turn machine on. Machine will start in dry cleaning mode.

**2.** Recline the machine to start the brush roll spinning. Use forward and backward passes for best results.

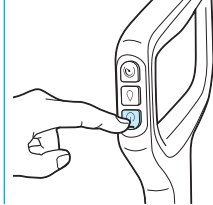
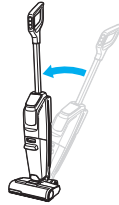

**1.5 sec**

For larger messes and area rugs, switch to Turbo Mode for additional suction.

**3.** Return machine to upright position to stop. **Note:** When powering off or returning upright, machine runs for 1.5 secs to remove debris. Wait for it to finish powering down before moving.

## Emptying the Dirty Tank

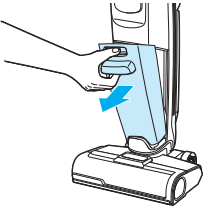

**1.** Press button on top of dirty tank and pull out.

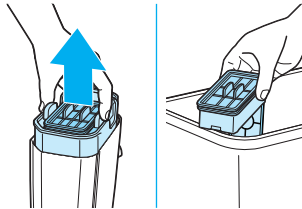

**2.** Remove top of tank by grabbing lid in recessed area on either side of the filter. Remove filter from lid, open the screen and tap in trash.

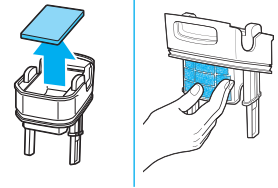

**3.** Remove the foam layer from the tank lid. Wipe any debris from the foam piece and mesh screen, ensuring debris is removed.

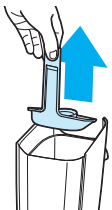

**4.** Pull the strainer tab up and remove debris. Empty tank into trash can.

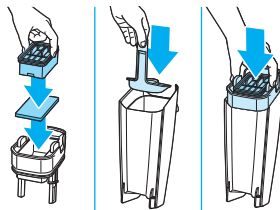

**5.** Reinsert the foam and filter into the lid. Place the strainer in the dirty tank, then return lid to dirty tank.

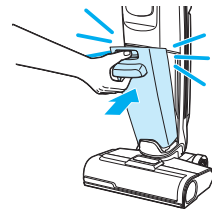

**6.** Insert bottom of tank first. Tilt tank towards machine until it clicks into place.

# Power Mop Mode



For optimal performance, use genuine BISSELL formulas in your machine\*. Other formulas or household cleaners may cause defects or damage to the machine.

**When using both modes in one cleaning session, start with Power Vac mode for dry cleaning before using Power Mop Mode. Allow parts to dry completely after use.**

<p><b>1.</b> Remove clean water tank by pressing latch and tilting tank backward. Open cap on top of tank.</p>	<p><b>2.</b> Fill with warm (140°F/60°C MAX) tap water to fill line. Do not use boiling water. Do not heat water in microwave. Add cleaning formula to formula fill line.</p>	<p><b>3.</b> Close cap until it clicks before installing in the unit. Reinsert bottom of tank and tilt tank toward machine until it clicks.</p>		
<p><b>4.</b> Press power button to turn machine on. Recline machine to begin cleaning. Return to upright position to stop.</p>	<p><b>5.</b> Press cleaning mode button to switch to Power Mop Mode. Wait 10-15 seconds to allow machine to fully wet brush roll.</p>	<p><b>6.</b> For best results, use forwards and backwards passes when cleaning.</p>		
<p><b>7.</b> For larger messes and area rugs, switch to Turbo Mode (A) for additional cleaning fluid and suction.</p>	<p><b>8.</b> When clean water tank is empty, machine will beep and display add water icon.</p>	<p><b>9.</b> If the dirty tank is full, machine will beep and display dirty tank full icon. Empty the tank (pg 8).</p>		

\*Compatible BISSELL formulas include: Pet Multi-Surface Formula Lemon-Eucalyptus, Pet Multi-Surface with Febreze Formula, Pet Simply Multi-Surface Formula, Multi-Surface Formula, Hard Floor Sanitize Formula, Wood Floor Formula, FreshStart™ Clean Out Cycle Formula

FEBREZE is used under license from The Procter & Gamble Company or its affiliates.

CONTINUED ON NEXT PAGE

global.BISSELL.com **7**

## Sanitizing Hard Floors

BISSELL Hard Floor Sanitize formula is for use on hard, sealed floors only. Do not use on carpet or area rugs. Read formula container label fully prior to use.

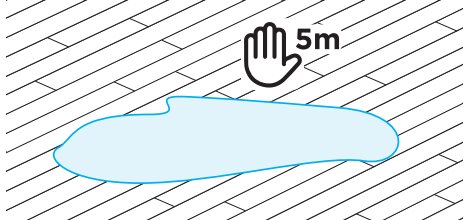
	
<p><b>1.</b> Follow cleaning instructions on page 7 to remove visible soils.</p> <p><b>To Sanitize:</b> Using BISSELL Hard Floor Sanitize formula and with machine in Power Mop Mode, make forward and backward passes. Solution will dispense automatically.</p>	<p><b>2.</b> Allow floor to remain visibly wet with formula for five minutes. This may require additional passes in Power Mop Mode.</p>

## Emptying the Dirty Tank

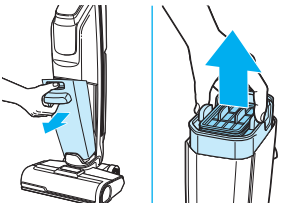
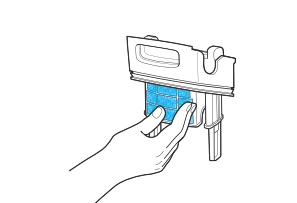
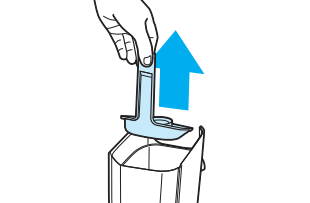
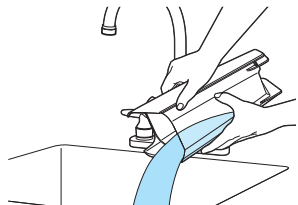
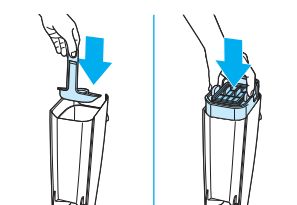
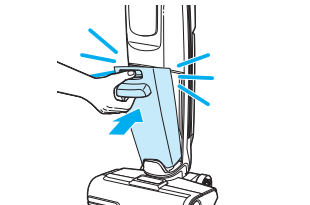
		
<p><b>1.</b> Press button on top of dirty tank and pull out. Remove top of tank by grabbing lid in recessed area on either side of filter to remove.</p>	<p><b>2.</b> Clean mesh screen, ensuring all debris is removed.</p>	<p><b>3.</b> Pull strainer tab up and out of tank to separate debris from dirty water. Dispose of debris.</p>
		
<p><b>4.</b> Pour out dirty water and rinse tank and tank lid.</p>	<p><b>5.</b> Place the strainer in the dirty tank, then return lid to dirty tank.</p>	<p><b>6.</b> Insert bottom of tank first. Tilt tank towards machine until it clicks into place.</p>

CONTINUED ON NEXT PAGE ➔

## Using the Clean-Out Cycle

For use after wet cleaning only. A minimum battery charge level of 11% is required to run the clean-out cycle.

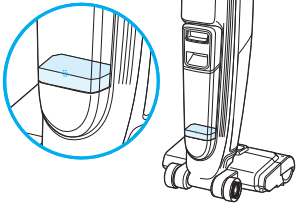
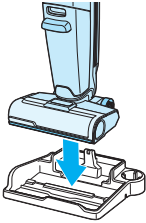
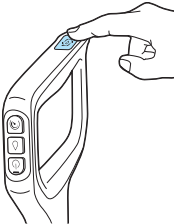
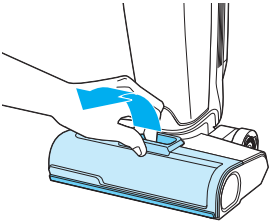
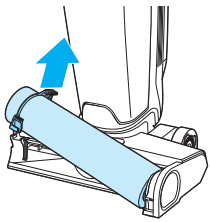
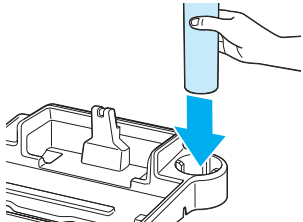
		
<p><b>1.</b> Empty dirty tank. Ensure solution in clean water tank reaches the Clean-Out Cycle line.</p>	<p><b>2.</b> Place the machine on the 3-in-1 Docking Station.</p>	<p><b>3.</b> Push Clean-Out Cycle Button to start 40-second cycle.</p>
		
<p><b>4.</b> To release brush roll window, press button on window and rotate window towards you.</p>	<p><b>5.</b> Pull brush roll tab to remove.</p>	<p><b>6.</b> Place brush roll in brush holder on dock to dry.</p>

**Note:** If brush roll is still dirty, it can be hand washed with mild detergent and placed in brush roll holder on docking station to dry.

For best results, replace brush roll every 3 months.

## After-Cleaning Care



Important: Filter must be cleaned and dried after every Power Mop Mode use to maximize suction and performance. Replace filter every 3 months.

<p><b>1.</b> Empty and rinse dirty tank and tank lid (pg 8). Remove filter from top of tank by grabbing tabs on filter and lifting up. Remove any debris from under filter.</p>	<p><b>2.</b> Open, then wash the filter, foam piece, and dirty tank lid with warm water and mild detergent. Rinse all debris from dirty tank cover.</p>	<p><b>3.</b> Press button to release brush roll window. Pull brush roll tab to remove.</p>
<p><b>4.</b> Hand wash brush roll and window with water and mild detergent.</p>	<p><b>5.</b> Remove machine from dock to wipe out tray. Do not rinse tray under faucet to avoid water entering charging plug.</p>	<p><b>6.</b> Allow parts to dry completely before installing.</p>
<p><b>7.</b> After fully dry, replace lid and strainer on the dirty tank and filter at the top. Insert bottom of tank into machine first. Tilt tank towards machine until it clicks into place.</p>	<p><b>8.</b> Insert right side of brush roll first and rotate downward until tab on left side of brush is locked in place.</p>	<p><b>9.</b> Reinstall window by lining up tabs on bottom edges of foot and rotating towards machine. Press down until window clicks into place.</p>

**Note:** Any other maintenance or servicing not included in this manual should be performed by an authorized service representative.

# Troubleshooting

🔧 Below are some of the issues you may run into. If you don't see the issue you're experiencing below, visit [global.BISSELL.com](http://global.BISSELL.com).

Problem	Possible Cause	Remedies
Streaking or loss of suction power	Brush roll window is not latched.	Reinstall brush roll window.
	Debris channel in foot is clogged.	Clean channel with a paper towel.
	Mesh screen in dirty tank is clogged.	Remove debris from mesh screen and empty tank.
	Filter is clogged.	Remove filter and remove any debris from filter screen or underneath the filter.
	Filter is wet.	Check screen and paper pleats for moisture. Allow to dry for 24 hours before reinstalling.
	Brush roll is wet and dirty.	Clean and dry brush roll.
Leaking	Clean water tank or lid is damaged.	Remove tank from machine and inspect for damage on tank and/or lid. If damage is found, order replacement tank and/or lid.
	Dirty tank is damaged.	Remove tank from machine and inspect for damage. If damage is found, order replacement tank.
	Dirty tank is full.	Empty tank.
Clean-Out Cycle not working	Machine is not on storage tray.	Place machine on storage tray.
	Clean tank low.	Refill tank.
	Dirty tank is full.	Empty tank before starting the Clean-Out Cycle.
Brush roll not spinning	Hair stuck on end of brush roll or by brush roll tab.	Remove brush roll from machine and clean any hair from the end of the brush roll and from foot. Rotate the small section of the brush roll clockwise to remove and clean any hair from brush tab. Rotate counterclockwise to reinstall.
Partial clog has been detected	Filter is clogged or there is a clog in the hose of the machine.	Replace the filter with a clean filter and confirm if clog detection still occurs. If clog detection persists, remove the brush roll window and brush roll and check for a clog. Remove any debris from the dirty tank screen and check the tube in the middle of the tank for any debris.

Error Code	Possible Cause	Remedies
E1	Full system clog has been detected	Replace the filter with a clean filter. If E1 error persists, remove brush roll window and brush roll to check for clogs. Clear any debris from the dirty tank screen and the tube in the middle of the tank.
E2	Brush roll stuck	Remove brush roll window and brush roll to check for debris in foot. Remove any accumulated hair from brush roll.
E3	Fan error	Contact BISSELL Consumer Care.
E4	Battery communication error	Contact BISSELL Consumer Care.

# Limited Warranty

This limited warranty is provided by BISSELL® International Trading Company B.V. ("BISSELL") and applies in Australia and New Zealand. It gives you specific rights. It is offered as an additional benefit to your rights under law. You also have other rights under The Australian Consumer Law or New Zealand Consumer Laws, whichever applies to you. You can find out about your legal rights and remedies by contacting your local consumer advice service. Nothing in this warranty will replace or lessen any of your legal rights or remedies. If you need additional instruction regarding this warranty or have questions regarding what it may cover, please contact BISSELL Consumer Care or contact your local distributor.

This warranty is given to the current owner of the product with the original sales receipt. The original sales receipt must include the product(s) purchased, the date purchased, and which country it was purchased from new. You must be able to evidence the date of purchase and show the product was purchased in Australia or New Zealand to submit a claim under this warranty. You will receive the warranty that is applicable to the country where your product was originally purchased, as shown on the original sales receipt. If you use the product outside of the country where it was purchased, your warranty may be void in BISSELL's sole discretion. It may be necessary to obtain some of your personal information, such as a mailing address, to fulfill the terms of this warranty. Any personal data will be handled pursuant to BISSELL's Privacy Policy, which can be found at [global.BISSELL.com/privacy-policy](http://global.BISSELL.com/privacy-policy).

## Limited Two-Year Warranty

For the specified duration above from the date of purchase by the original purchaser, subject to the \*EXCEPTIONS AND EXCLUSIONS identified below, BISSELL will repair or replace (with new, refurbished, lightly used, or remanufactured components or products), at BISSELL's option, free of charge, any defective or malfunctioning part or product.

BISSELL recommends that the original packaging and original proof of purchase with the date of purchase and country where purchased be kept for the duration of the warranty period in case you want to redeem the warranty during the warranty period. Keeping the original packaging will assist with any necessary re-packaging and transportation but is not a condition of the warranty.

If your product is replaced by BISSELL under this warranty, then the new item will benefit from the remainder of the term of this warranty (calculated from the date of the original purchase). The period of this warranty shall not be extended whether or not your product is repaired or replaced.

## \*Conditions of Warranty

This warranty applies to products used for personal domestic use and not commercial or hire purposes. Consumable components and attachments such as filters, belts, shells, water tanks, scraping strips, brushes, and mop pads, which must be replaced or serviced by the user from time to time, are not covered by this warranty.

This warranty does not apply to any defect arising from fair wear and tear, including but not limited to the battery discharging time shortening due to the aging or use. Damage or malfunction caused by the user or any third party whether as a result of accident, negligence, abuse, neglect, or any other use not in accordance with the user guide is not covered by this warranty. An unauthorised repair (or attempted repair)

may void this warranty whether or not damage has been caused by that repair/attempt. Removing or tampering with the Product Rating Label on the product or rendering it illegible will void this warranty.

Except as set out below, BISSELL and its distributors are not liable for any loss or damage that is not foreseeable or for incidental or consequential damages of any nature associated with the use of this product including without limitation loss of profit, loss of business, business interruption, loss of opportunity, distress, inconvenience, or disappointment. Except as set out below, BISSELL's liability will not exceed the purchase price of the product.

BISSELL does not exclude or limit in any way its liability for (a) death or personal injury caused by our negligence or the negligence of our employees, agents or subcontractors; (b) fraud or fraudulent misrepresentation; (c) or for any other matter which cannot be excluded or limited under law.

To make a claim under this warranty contact BISSELL Australia PTY LTD (details below). Contact BISSELL prior to returning any goods. Where agreed, BISSELL will reimburse reasonable postage / handling costs (if any) for returning goods to BISSELL. To claim expenses incurred in making a claim under this warranty please provide BISSELL with a copy of the receipt of the expenses by email or post.

For Australian Consumers Only: Our goods come with guarantees that cannot be excluded under the Australian Consumer Law. You are entitled to a replacement or refund for a major failure and compensation for any other reasonably foreseeable loss or damage. You are also entitled to have the goods repaired or replaced if the goods fail to be of acceptable quality and the failure does not amount to a major failure.

## Important Notes

Please keep your original sales receipt. It provides proof of the date of purchase and where it was purchased in the event of a warranty claim. See warranty for details.

Please note that using your BISSELL machine outside of its country of original purchase and/or use with a power converter may damage your BISSELL machine and damage caused by mismatched power voltage will not be covered by your warranty.

Please note that putting vinegar, bleach, dish soap, detergent, homemade soap, and other non-BISSELL products in your BISSELL machine may damage your BISSELL machine. Damage caused by using non-BISSELL products in your machine will not be covered by your warranty.

## Consumer Care

If your BISSELL product should require service or to claim under our limited guarantee, please contact us.

### Australia

Telephone: 1300 247 735

Website: [BISSELL.com.au](http://BISSELL.com.au)

Address: 789 Springvale Road, Mulgrave, Victoria 3170

Email: [consumercareau@bissell.com](mailto:consumercareau@bissell.com)

### New Zealand

Telephone: 0800 247 735

Website: [BISSELL.co.nz](http://BISSELL.co.nz)

Address: 789 Springvale Road, Mulgrave, Victoria 3170

Email: [consumercarenz@bissell.com](mailto:consumercarenz@bissell.com)

