

# MD200H90WB/T-AU

9kg Heat Pump Dryer | MD200 Series | Titanium



FEATURES	
Colour	Titanium
Capacity	9kg
Display	White LED
Control Interface	Haptic Lunar Dial & Touch Control
Connectivity	Wi-Fi via SmartHome App
No. of Programs	14
Motor Type	BLDC Inverter
Porthole Diameter	375mm
Drum Light	Yes
Water Drainage	Tank or Plumbed
Drying Programs	Cotton Extra      Wool Cotton - ECO      1 Shirt Cotton - Iron      5 Shirts Mix                  Jeans Synthetics -      Bed Linen Cupboard          Baby Care Synthetics -      Outdoor Cupboard          Time Dry
Aux Functions	Intensity   Airfresh   UV Hygiene Anti Crease   Lamp Time +/-   Child Lock

# MD200H90WB/T-AU

9kg Heat Pump Dryer | MD200 Series | Titanium

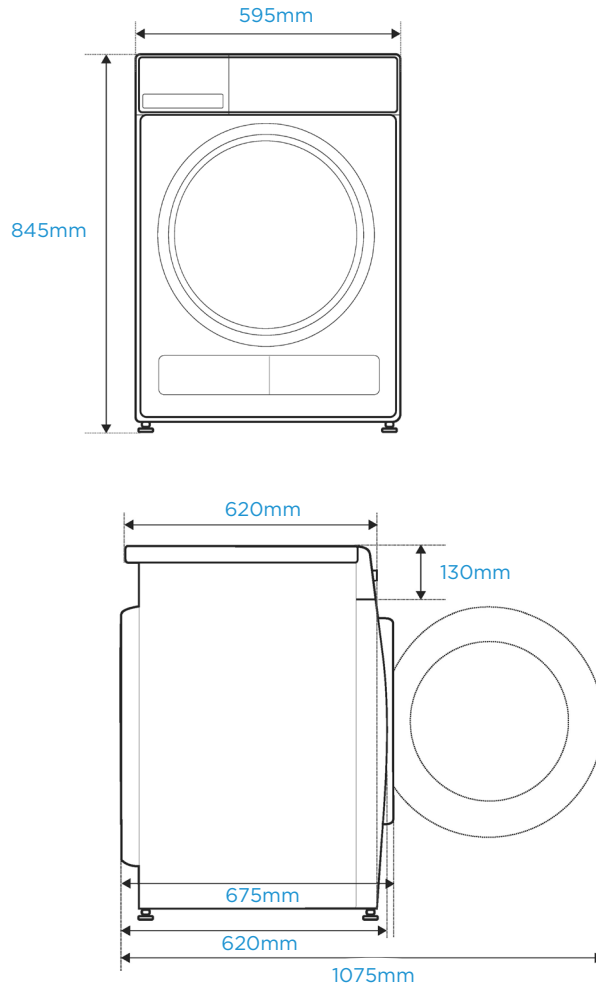

## SPECIFICATIONS

Energy Rating	9 ★
Energy Consumption Per Year	143kWh
Electrical Connection	10A Plug & Lead
Power Input & Supply	750W   220-240V ~ 50Hz
Refrigerant Type   Quantity	R290   130g
Power Cord Length	1.5m
Drainage Hose Length	2m

## PRODUCT & PACKAGING INFORMATION

Carton Dimensions W x D x H	679 x 709 x 885mm
Product Dimensions W x D x H	595 x 675 x 845mm
Gross Weight	52kg
Net Weight	48kg
EAN	6 945878 353947

## WARRANTY

Product	3 Years Parts & Labour
BLDC Inverter	12 Years Parts Only



Visit Us

VERSION NO. 20251003

Product and cut-out dimensions are to be used as a guide only. Please refer to actual product before installing or refer to the instruction manual or website for full instructions.

[www.midea.com/au](http://www.midea.com/au)