

# R-VX410PT9

375lt Top Mount Freezer INVERTER Refrigerator  
**SELECTABLE ZONE SERIES**

## Features

- 375lt Capacity
- Top Mount Freezer
- Selectable Zone
- INVERTER refrigerator
- Only 308kWh per year power consumption
- Warranty: 5 Year Parts & Labour Warranty (Additional 5 Years Parts Warranty on the Inverter Compressor)
- LED Lighting
- Tempered Glass Shelves
- Dual Fan Cooling
- Dual Sensing Control (with Eco Thermo-Sensor)
- Triple Power Filter
- Mould proof Door Gasket
- No Frost
- CFC-Free
- HFC-Free
- Movable Twist Ice Tray
- Finishes: Brilliant Black or Brilliant Silver



**INVERTER**  
 X  
**Dual Fan Cooling**

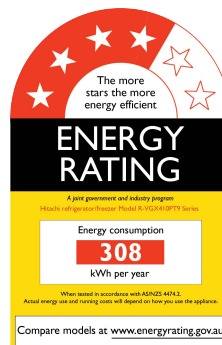

### Selectable Zone

Soft Freeze -3°C	Chill/Meat	Refrigerator 3°C
<b>Meat &amp; Fish</b> Choose the Soft Freeze setting to keep meat and fish fresh; you can easily cook them instantly without the need to defrost.	<b>Dairy &amp; Meat</b> Keep your dairy, meat and fresh food in ideal 1°C in the Chill/Meat setting.	<b>Drinks &amp; Foods</b> Running out of space for your drinks and food? You can now have extra storage refrigerator space at 3°C.
<b>Cook instantly without the need to defrost with Soft Freeze -3°C</b>		
 <b>Easy Cutting</b> Softly frozen foods are easy to slice.	 <b>Easy to Prepare Portions</b> Just take the amount that is needed.	 <b>Cook Immediately</b> Cook without the need to defrost the food.

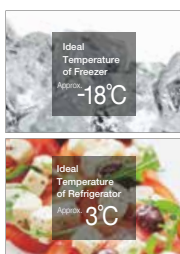

## Dual Sensing Control

Hitachi Refrigerators have two Eco Thermo Sensors, which detect any temperature changes separately to enable the ideal temperatures to be maintained in each of the compartments at all times. If a refrigerator has only one sensor, which is usually in the refrigerator compartment, temperature changes in the freezer due to various factors can't be detected and stored items won't be properly frozen. Having an additional sensor also in the freezer ensures that won't happen and every item that is stored in each compartment is kept in ideal condition.





R-VX410PT9BBK



R-VX410PT9BSL



R-VX410PT9BBK Interior

## Movable Twist Ice Tray



You can move the ice tray for more convenient and efficient use of storage space.

\*Without Ice Tray

## Bright, Energy Saving LED Light



Refrigerator features LED lighting that lasts a long time and consumes less energy than conventional lamp.

## Mould proof Door Gasket

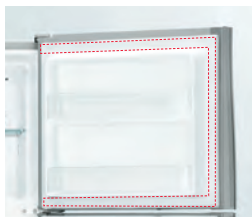

Thanks to Hitachi's mould-proofing treatment, the door gasket can be cleaned easily.

## Tempered Glass Shelves



Scratch-proof and heat-resistant, the tempered glass shelves can even hold up to 100kg\* each.

## Powerful Deodorisation

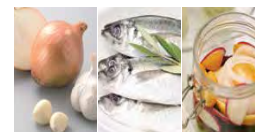

### Triple Power Filter

Triple Power Filter removes odour components\*<sup>1</sup> and removes bacteria 99%.\*<sup>2</sup>



## Dual Fan Cooling – Dedicated Fans

With the high power Inverter Compressor and the dedicated fans for each of the compartments, it assures powerful refrigeration and exceptional energy saving at the same time.

Capacity: 375L  
 Freezer: 125L | Refrigerator: 250L  
 Dimensions: 1,605(h) x 650(w) x 720(d) mm  
 Cabinet Depth (without Door): 614mm

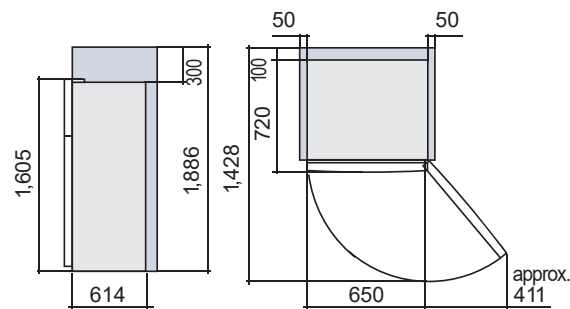

□ Space required for ventilation.

\*<sup>1</sup> Triple Power Filter that catches and removes 7 odour components (Tested by Hitachi. The type of odours : Methyl Mercaptan, Ammonia, Acetaldehyde, Trimethylamine, Propanal, Hexanal and Acetic Acid).  
 \*<sup>2</sup> Thus also provides a sterilising effect. Combining the properties of Activated Carbon, Zeolite and Manganese Oxide (catalyst), the filter greatly reduces the percentage of odours present over time. Testing organisation : Boken Quality Evaluation Institute. Testing method : Film adhesion method (JISZ2801). Name of processing component : Filter. Sterilisation method : Application of oxidation catalyst to filter. Subject : Bacteria trapped in filter. Test results : 99% sterilised after 24 hours, achieved using the filter alone. No effect on the environment and food inside the refrigerator.