

# 60cm 12 Function Double Oven Midnight

## SERIES

Contemporary

## AESTHETICS

Black Glass with Midnight Trim

Midnight Fluted Steel Knobs

Midnight Aluminium Handle

Black Tinted Triple Glazed Door

Grey Crystal Clean Enamel Cavity

## FUNCTIONALITY

Upper Capacity: 32.5L Net / 42L Gross

Lower Capacity: 56L Net / 65L Gross

12 × Functions (4 × Upper / 8 × Lower)

Knob Control with Touch Control Timer

60–250°C Temperature Range

LED Display

5 × Shelf Positions

2 × Interior Lamps

Turbo Ring Elements

Cavity Cooling System

Removable Doors and Inner Glass



## FRONT VIEW

Note: See the user manual for detailed ventilation and installation details

## UPPER FUNCTIONS

- |          |                 |
|----------|-----------------|
| 1. Light | 5. Convection   |
| 2. Grill | 6. Classic Bake |

## LOWER FUNCTIONS

- |                 |                  |
|-----------------|------------------|
| 1. Light        | 5. Fan & Grill   |
| 2. Conventional | 6. Fan Forced    |
| 3. Pastry Bake  | 7. Brown (Broil) |
| 4. Grill        | 8. Defrost       |

## ACCESSORIES

3 × Chrome Wire Shelves

2 × Enamelled Baking Tray

2 × Grill Insert and Wire Handles

1 × Tempered Glass Tray

## SIZE, W/D/H (MM)

|                   |                 |
|-------------------|-----------------|
| Packaged          | 647 × 680 × 945 |
| Physical          | 594 × 581 × 888 |
| Lower Door Height | 460             |

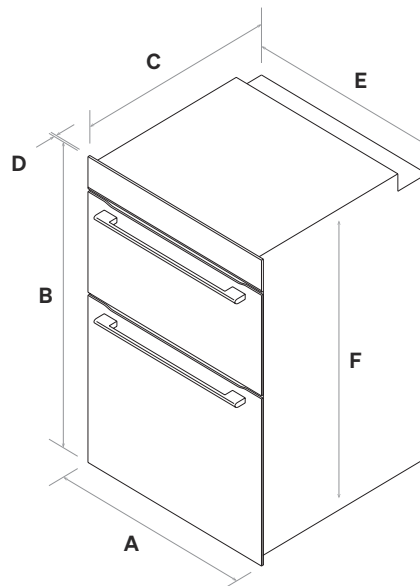

## DIMENSIONS (MM)

|   |     |   |     |   |     |
|---|-----|---|-----|---|-----|
| A | 594 | B | 888 | C | 560 |
| D | 21  | E | 547 | F | 868 |

## WEIGHT (KG)

Net: 56                      Gross: 63

## INSTALLATION

Built-in Installation

## POWER REQUIREMENTS

|                  |                   |
|------------------|-------------------|
| Power Connection | 25 Amp, Hardwired |
| Rated Voltage    | 220–240V          |
| Rated Frequency  | 50Hz–60Hz         |
| Maximum Power    | 4200–5100W        |

## ADDITIONAL DETAILS

|          |               |
|----------|---------------|
| Barcode  | 9349260096714 |
| Warranty | 3 Years       |

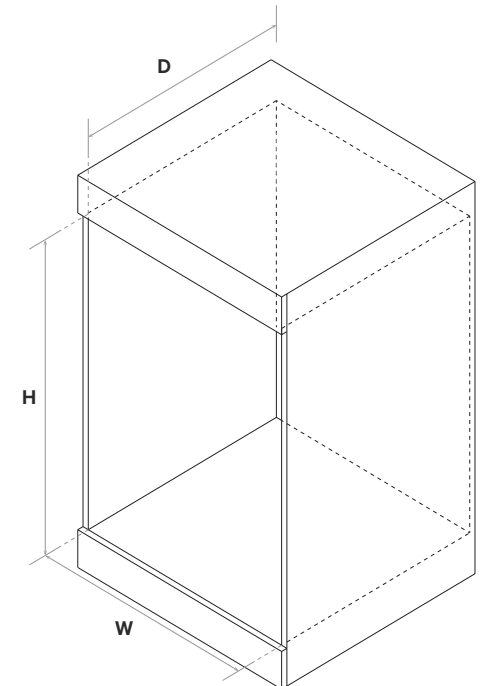

## MINIMUM INSIDE CAVITY (MM)

|   |     |   |             |
|---|-----|---|-------------|
| W | 597 | D | 560 (Proud) |
| H | 890 | D | 581 (Flush) |