

MF110W80B/W-AU

8kg Front Load Washing Machine | MF110 Series | White

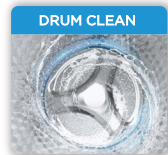

FEATURES	
Colour	White
Capacity	8kg
Max Spin Speed	1400RPM
Display	White LED
Control Interface	Rotary Dial Touch Button
No. of Programs	15
Motor Type	BLDC Inverter
Inner Tub Diameter	510mm
Porthole Diameter	280mm
Temperature Settings	Cold 20°C 30°C 40°C 60°C 90°C
Wash Programs	Quick 15'/45' Cotton Delicate Synthetics 20°C Cotton Eco Bulky Mix Health Guard Jeans Allergy Care Handwash Rinse & Spin Spin Only Drum Clean
Aux Functions	Turbo Pre Wash Extra Rinse Child Lock Delay End

MF110W80B/W-AU

8kg Front Load Washing Machine | MF110 Series | White

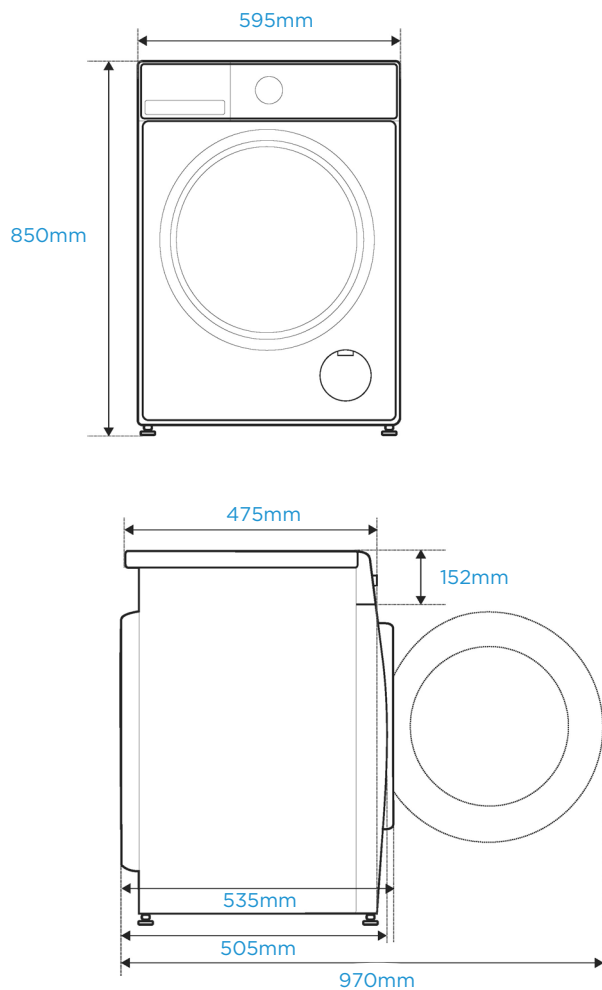

SPECIFICATIONS

Energy Rating	4.5 ★
Energy Consumption Per Year	244kWh
Water Rating	4.5 ★
Litres Per Wash	68L
Electrical Connection	10A Plug & Lead
Power Input & Supply	1950W 220-240V ~ 50Hz
Power Cord Length	1.5m
Inlet Hose Length	1.0m
Outlet Hose Length	2.1m

PRODUCT & PACKAGING INFORMATION

Carton Dimensions W x D x H	655 x 560 x 885mm
Product Dimensions W x D x H	595 x 535 x 850mm
Gross Weight	63kg
Net Weight	60kg
EAN	6 945878 351950

WARRANTY

Product	3 Years Parts & Labour
BLDC Inverter Motor	12 Years Parts Only



Visit Us

VERSION NO. 20250923

Product and cut-out dimensions are to be used as a guide only. Please refer to actual product before installing or refer to the instruction manual or website for full instructions.

www.midea.com/au