

76cm Integrated Refrigerator & Freezer

MODEL AINT7600

MODEL AINT7600IW WITH ICE & WATER

 **ARTUSI**
THE ART OF LIVING



36 MONTH WARRANTY



90CM



LED LIGHTS



TOUCH CONTROL



*2+3 Years with product registration



DIGITAL DISPLAY



ENERGY RATING



PRODUCT INFORMATION

FEATURES

- Internal LED touch control display
- Bottom mount double french door fridge & freezer
- Built-in integrated installation
- White interior
- Internal filtered water dispenser (AINT7600FDIW only)
- Super cool function
- Super freezing function
- Fan ventilation
- Holiday function
- Frost free & auto defrost
- Side wall cavity LED panels (2) illuminate the entire fridge cavity
- Lower drawer LED lights
- Ceiling LED panel illuminates the freezer cavity
- Automatic ice maker (when activated, AINT9100FDIW only)
- Removable ice tray/bucket (AINT7600FDIW only)
- Ice making capacity: 1.7kgs per day
- Sabbath mode
- ECO mode
- Automatic keypad lock

CAPACITY

- Refrigerator: 267L net
- Chill Zone: 56L
- Freezer: 126L net
- Total net: 449L

DISCLAIMER

Eurolinx & Worldwide appliances Pty Ltd, is continually seeking ways to improve the design specifications, aesthetics and production techniques of its products. As a result alterations to our products and designs take place continually. Whilst every effort is made to produce information and literature that is up to date, this brochure should not be regarded as an infallible guide to the current specifications, nor does it constitute an offer for the sale of any particular product. Product dimensions indicated in our literature is indicative only. Actual product only should be used to define dimension cut outs. Distributors, and retailers are not agents of Eurolinx or Worldwide appliances and are not authorised to bind Eurolinx or Worldwide appliances by any express or implied undertaking or representation.

TEMPERATURE RANGE

- Fridge: 8°C - 2°C
- Chill Zone: 5°C - -1°C
- Freezer: -15°C - -24°C

COMPARTMENTS

- 3 fridge cavity shelves (2 are adjustable)
- 1 x vegetable crisper drawers
- 1 x meat/cheese storage
- 3 x door shelf buckets
- 1 large metal freezer drawer compartment
- 2 deep storage freezer compartments

ACCESSORIES

- 1 x egg tray
- 1 x ice tray (AINT7600FDIW only)

TECHNICAL INFORMATION

- Front & rear adjustable / levelling feet
- Noise: 43 dB
- Power failure storage time: 11 hours
- Freezing capacity: 7kg/24 Hours
- Dual evaporator & frost free cooling
- max. door weight: 13.4kgs fridge door
- max. door weight: 7.4kgs freezer door
- max. door thickness: 18mm
- More, see page 2

AR03092024

FOLLOW US ON:  [/artusi_kitchen_laundry_outdoor](https://www.instagram.com/artusi_kitchen_laundry_outdoor)

Australia National Telephone Number 1300 694 583
For showroom opening times, visit our website

artusi.com.au

NSW & ACT (Head Office)
48-50 Moore Street
Leichhardt
F 02 8569 4699

Victoria
2r/131 Church Street
Hawthorn

QLD
Contact Head Office

WA & NT
Contact Head Office

76cm Integrated Refrigerator & Freezer

MODEL AINT7600

MODEL AINT7600IW WITH ICE & WATER

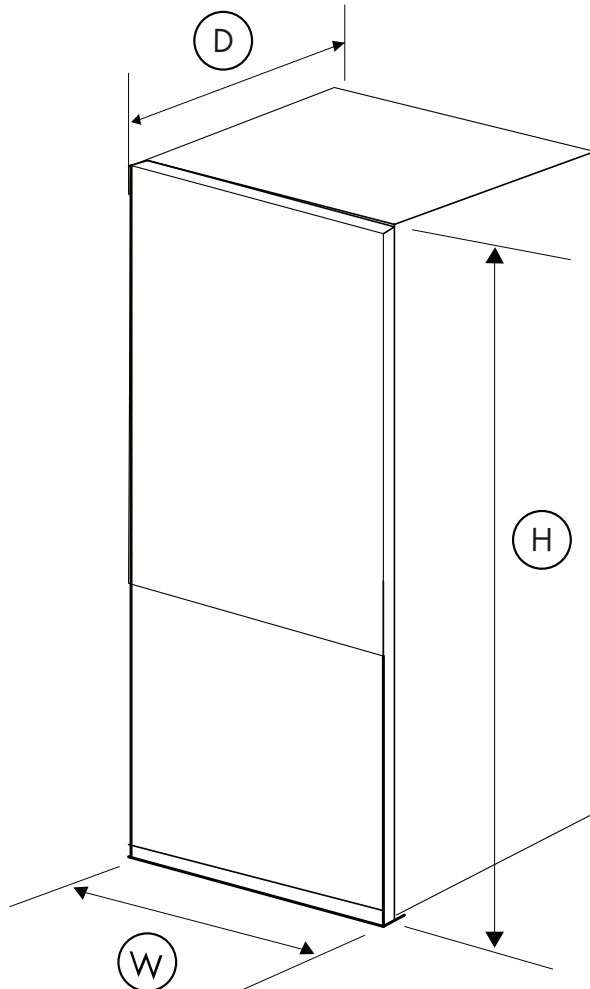

- W 756mm
- H 2123mm
- D 592mm (without panel)

Technical Information AINT7600 & AINT7600IW
Weight: 167 Climate class: T
Annual energy consumption: 488kWh/year
Electrical Connection: 10AMP GPO

NB: drawings are not to scale — for detailed installation instructions, please refer to user guide.

AIN7600 EAN 9347777005502

AIN7600IW EAN 9347777005496 AR03092024

DISCLAIMER

Eurolinx & Worldwide appliances pty Ltd, is continually seeking ways to improve the design specifications, aesthetics and production techniques of its products. As a result alterations to our products and designs take place continually. Whilst every effort is made to produce information and literature that is up to date, this brochure should not be regarded as an infallible guide to the current specifications, nor does it constitute an offer for the sale of any particular product. Product dimensions indicated in our literature is indicative only. Actual product only should be used to define dimension cut outs. Distributors, and retailers are not agents of Eurolinx or Worldwide appliances and are not authorised to bind Eurolinx or Worldwide appliances by any express or implied undertaking or representation.

FOLLOW US ON:  [/artusi_kitchen_laundry_outdoor](https://www.instagram.com/artusi_kitchen_laundry_outdoor)

Australia National Telephone Number 1300 694 583
For showroom opening times, visit our website

artusi.com.au

NSW & ACT (Head Office)
48-50 Moore Street
Leichhardt
F 02 8569 4699

Victoria
2r/131 Church Street
Hawthorn

QLD
Contact Head Office

WA & NT
Contact Head Office