



APPLIANCES FOR LIVING

 **ARTUSI**
THE ART OF LIVING

AIN119/2
OPERATION MANUAL

Congratulations, you are now the proud owner of an ARTUSI cooking appliance. Thank you for purchasing ARTUSI and welcome to the ARTUSI Family.

This instruction manual has been specially created to inform you of the full range of features your ARTUSI appliance has to offer and serves as an introduction to getting the very best out of your ARTUSI appliance.

We present detailed information on each of the features your ARTUSI appliance consists of. Once you have read this section you will be able to choose the most appropriate settings for your appliance when cooking different types of food.

We ask you to read the instructions in this booklet very carefully as this will allow you to get the best results from using your appliance. **KEEP THE DOCUMENTATION OF THIS PRODUCT FOR FUTURE REFERENCE.**

**TO REGISTER YOUR PRODUCT WITH ARTUSI, PLEASE FILL OUT THE WARRANTY CARD AT THE END OF THIS BOOKLET AND POST IT TO: REPLY PAID 83617
LEICHHARDT NSW 2040**

Dear Artusi Customer, please read this user manual carefully before using the product and, keep it permanently at your disposal.

Note: This user manual is prepared for more than one model. Some of the features specified in this Manual may not be available on your appliance.

All our appliances are only for domestic use, not for commercial use. Products marked with (*) are optional.

“THIS APPLIANCE SHALL BE INSTALLED IN ACCORDANCE WITH THE REGULATIONS FORCE AND ONLY USED IN A WELL VENTILATED SPACE. READ THE INSTRUCTIONS BEFORE INSTALLING OR USING THIS APPLIANCE”

“Conforms with the WEEE Regulations.”

Contents

3	Important information
5	Important safety and usage instructions
6	Before first use
7	General use of the fridge
8	General use of the freezer (icebox)
9	Storage and use
10	Controls
11	Care and cleaning
12	Defrosting the fridge
12	Defrosting the Icebox
13	Troubleshooting
15	Installation and ventilation
16	Mounting the fascia doors
18	Reversing the fridge door
19	Reversing the icebox door
20	Electrical information
22	Changing the light bulb
22	Climate range
23	Practical tips

IMPORTANT: Please read the user instructions carefully before using the appliance for the first time and before installing it. Failure to install the appliance, or to have it installed, as per the user manual could invalidate the warranty. Any service calls relating to misuse or incorrect installation could incur a service charge.

Important Information

The Manufacturer cannot be held responsible for injuries or losses caused by incorrect use or installation of this product. Please note that the Manufacturer reserves the right to invalidate the guarantee supplied with this product following incorrect installation or misuse of the appliance or use in a commercial environment.

This appliance is not designed to be used by people (including children) with reduced physical, sensorial or mental capacity, or who lack experience or knowledge about it, unless they have had supervision or instructions on how to use the appliance by someone who is responsible for their safety.

Under no circumstances should any external covers be removed for servicing or maintenance except by suitably qualified personnel.

Appliance information:

Please enter the details on the appliance rating plate below for reference, to assist Customer Care in the event of a fault with your appliance and to register your appliance for guarantee purposes.

Appliance Model	
-----------------	--

Serial Number	
---------------	--

EU Declarations of Conformity

This appliance has been manufactured to the strictest standards and complies with all applicable legislation, including Electrical safety (LVD) 2014/35/EU and Electromagnetic interference (EMC) 2014/30/EU. Parts intended to come into contact with food conform to 1935/2004/EC.

IMPORTANT INFORMATION FOR CORRECT DISPOSAL OF THE PRODUCT IN ACCORDANCE WITH EU DIRECTIVE 2012/19/EU.

At the end of its working life, the product must not be disposed of as urban waste. The refrigeration system contains insulating gases and refrigerants, which require specialised waste disposal. The valuable materials contained in this appliance can be recycled. It must be taken to a special local authority differentiated waste collection centre or to a dealer providing this service.

Before disposing of an old appliance, remove the door seals, latch or bolt lock to avoid the risk of child entrapment.

Disposing of a household appliance separately avoids possible negative consequences for the environment and health. It also enables the constituent materials to be recovered, saving both energy and resources. As a reminder of the need to dispose of household appliances separately, the product is marked with a crossed-out wheeled dustbin.



Important Safety and Usage Instructions

Never store inflammable or explosive items and strong corrosive acids or alkalis in the appliance.

This is a household appliance, which is produced in accordance with the national standard. It is intended for food storage only, not for storage of blood, medicine and biological products.

To prevent risk of fire, keep the appliance away from petrol or any other inflammables.

To prevent risk of electromagnetic interference or other accidents, do not place a microwave oven on top of the refrigerator or use any electric appliance inside the refrigerator.

Do not allow children to play with or near the appliance.

The internal surfaces of the fridge compartment may be very cold when the appliance is running. Avoid touching, if possible, the surfaces especially when hands are wet.

Do not splash water onto the appliance. Keep it away from places of high humidity that may have adverse effect on the electric insulation performance.

This appliance is designed to be used in ambient temperatures between 18°C and 43°C. Use outside of this range may cause the appliance to fail.

This refrigeration appliance is intended for use as a built-in appliance.

Before first use

You must allow the fridge to settle for at least twenty four hours prior to switching the power on.

It is recommended that you clean the interior of the appliance prior to first use, using a solution of bicarbonate of soda and warm water and then thoroughly drying the interior.

The fridge may have an odour to it at first use. This will disappear as the appliance cools.

When first switching the appliance on it is advisable to set the fridge to setting 3 and leave the fridge to settle for 24 hours before adjusting the temperature to the preferred setting.

Please note:

The appliance will work continuously until it comes down to the correct temperature.

If the appliance is switched off, you should allow five minutes before switching it on again to prevent unnecessary damage to the compressor.

Never store inflammable or explosive items and strong corrosive acids or alkalis in the appliance.

This fridge cools your food by making the inside back of the cavity cold. It is normal for frost to build up on this surface; it then dissipates and drains through a small drain at the bottom, where it evaporates harmlessly. The presence of frosting at the back is not a malfunction of the fridge.

The presence of frosting within the icebox of the appliance is not a malfunction of the icebox.

General use of the fridge

- Never put liquids in the refrigerator uncovered
- Never put hot foods in the refrigerator. Warm food should be allowed to cool to room temperature before being put into the refrigerator
- Nothing should rest against the rear wall of the refrigerator as this is a wet wall appliance which during normal use will form droplets of ice on the rear wall(refer to image on Page14)and cause items to freeze to the back wall
- Make sure food is clean and any extra water is wiped away before putting into the fridge
- Wrap or cover food before putting into the fridge. This will help prevent the loss of moisture, keep food fresh and avoid unpleasant odours
- Sort foods prior to storing. Any foods to be used soon should be stored at the front of the shelf to prevent deterioration caused by the door being open for prolonged periods
- Do not overfill the fridge. There should be sufficient space between the foods to allow the cool air to circulate
- Thawing frozen foods in the fridge compartment will help to keep the temperature low and save energy

General use of the Freezer(Icebox)

- The freezer compartment is designed to store only frozen food.
- Never put hot or warm foods in the freezer, allow them to cool fully before putting them into the freezer
- Follow the instructions on the food packaging for storage of frozen food. If no information is provided, foods should not be stored for more than three months after the purchase date
- Store food in small packages (ideally less than 0.5kg). This reduces the freezing time and improves the quality of the food after thawing
- Wrap food before putting into the freezer. To stop the wrapping sticking together, ensure it is dry
- Label the food before freezing with information including type of food and dates of storage and expiry
- Once food is thawed, it must not be refrozen unless it has been completely cooked. Only defrost as much food as is required, to prevent wastage
- Bottled or canned drinks should not be stored in the freezer compartment as they could explode
- The maximum amount of fresh food that can be frozen within a 24 hour period is approximately 2kg
- Do not attempt to freeze more than the maximum amount

Note: If the appliance does not have a freezer compartment () it is not suitable for freezing foodstuffs.

Storage and use

The fridge is for short term food storage. Although the temperature can be maintained between 0-10°C, extended periods of food storage is not recommended.

As the cold air circulates within the fridge, the temperature can vary between the different sections. As such, foods should be stored in different sections according to type.

1. Butter and eggs
2. Food in jars and bottles
3. Drinks, e.g. milk
4. Frozen food
5. Yoghurts and cheese
6. Fresh meat and fish
7. Fruit and vegetables

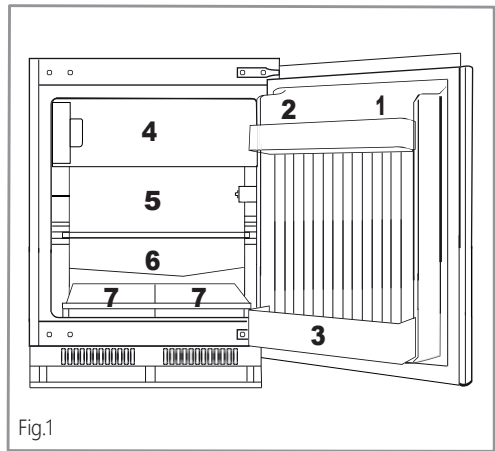

The fridge shelves can be moved according to the storage requirements within the fridge section. To move the shelf, lift up the front section and then pull it outwards. To replace, slide the shelf back into the slot, and lower the front section.

When storing root vegetables with leaves, such as carrots or turnips, their leaves should be removed. This prevents the leaves from absorbing nutrients from within the vegetables. The crisper cover shelf is split to allow easy access to the crispers.

Controls

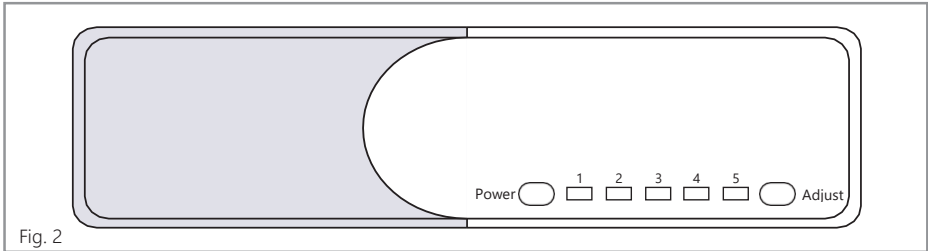

Temperature control

The temperature controls for this fridge are simple and easy to use. To change the temperature simply press the adjust button on the right hand side of the unit to cycle through settings 1 to 5. The warmest setting being 1 and the coldest being 5.

After changing the temperature setting, the time taken to achieve the new temperature will depend on how big the change is from the previous setting.

Switching on and off

When the fridge is connected to a power supply the lights below the setting numbers will illuminate, indicating which setting is currently being used.

To switch the appliance on and off simply press and hold the power button on the left hand side of the unit for approximately 5 seconds

Care and cleaning

Always disconnect the appliance from the power supply before any cleaning or maintenance.

The fridge and crisper sections should be cleaned using a solution of bicarbonate of soda and lukewarm water. Do not use abrasive products or detergents. After washing, rinse and dry thoroughly.

Clean the shelves, drawers and balconies separately by hand with a mild solution of washing up liquid and water. Do not put them in the dishwasher.

The water drain hole at the back of the fridge compartment and the evaporating tray should be cleaned periodically to prevent the defrosted water from collecting inside the fridge compartment. The cleaning rod can be used to clean the drain hole. Always ensure that the drainage channel, visible at the rear of the appliance, is kept clear of debris. If you notice that the drain hole/ channel is iced over, use warm (**not boiling**) water to remove the ice blockage.

If the appliance is not to be used for prolonged periods of time, unplug and clean the appliance. The doors should be left slightly ajar to prevent the formation of mildew and unpleasant odours.

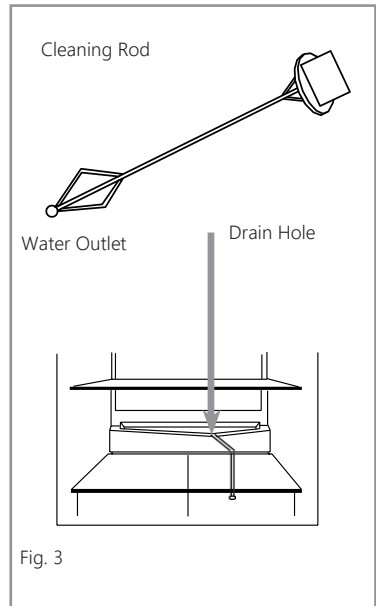

Defrosting the fridge

The fridge is self-defrosting. Any water created will run out of the fridge through the channel at the back of the fridge.

It is important to keep the channel clear at all times using the cleaning tool supplied.

The defrosted water is collected in the evaporating tray at the back of the appliance and dissipated by evaporation.

If you notice a heavy build up of ice, refer to the troubleshooting section on ice on page 13.

Defrosting the icebox

An excessive build-up of ice or frost in your icebox will lead to decreased efficiency and potentially increase your energy bills. We recommend defrosting the icebox at least once a year or whenever the ice build-up inside is thicker than $\frac{1}{4}$ of an inch.

The safest way to defrost your icebox is by switching the appliance off and leaving the doors open until all of the ice has melted away. Ensure you place old towels on the floor at the base of the appliance to catch any water that runs from the appliance. We advise against the use of newspapers to catch the water as the ink can run and ruin floors or units.

Removing chunks of the ice/frost as it is defrosting will speed up the process. Do not use any sharp objects or implements, hair driers or heat guns as these can cause irreversible damage.

Troubleshooting

If you have any problems with your appliance, you should check the troubleshooting ••••• prior to calling the Customer Care to prevent unnecessary service calls and potential cost. Contact details are on the back cover of this manual

If the appliance is not working, check the following:

- There is power to the appliance
- The house fuses are intact and the fuse in the plug has not blown
- The on/off switch is not set to off
- The plug socket is functioning ••••••••. To check this, plug another electrical appliance in to see if the socket is faulty

If the appliance is working, but not very well, check the following:

- The appliance is not overloaded
- The thermostat is set to an appropriate temperature
- The doors are closing properly
- The cooling system at the rear of the appliance is clean and free of dust, and not touching the rear wall
- There is enough ventilation at the side•rear walls•••••
••••••••••
- The lower vents are neither blocked nor dirty

If the appliance is noisy, check the following:

- The appliance is level and stable
- The side and rear walls are clear, and there is nothing resting on the appliance
- **Note:** The cooling gas in the refrigerator may make a slight bubbling or gurgling noise, even when the compressor is not running

If there is water in the lower part of the refrigerator compartment, check the following:

- The drain hole in the channel at the back of the refrigerator is clear. If this is blocked refer to Care and Cleaning (Page11)
- There are no items touching the rear wall of the appliance as this may cause them to freeze to the back wall and during the automatic de-frost function water may run on to the shelves as well as in to the lower part of the fridge

If ice has formed on the back wall of the fridge:

- It is normal for some ice droplets to form on the back wall of the fridge(see below image)as this is a wet wall fridge. This does not constitute a fault with the appliance
- Check that there is some resistance when opening the door of the appliance. If it opens at the slightest touch it may mean that the door seal needs to be replaced or the appliance is not correctly installed
- Check the door seal for any kinks, debris or damage. If you notice any, and are unable to resolve the issue yourself, contact the Customer Care so that the seal can be replaced

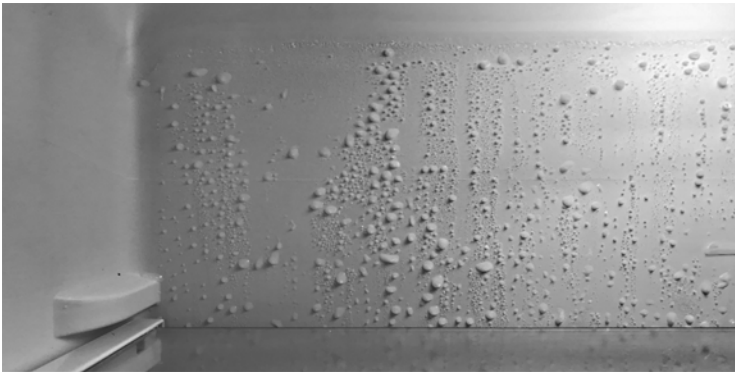

If excessive ice has formed in the icebox:

- This may mean that warm air is entering the fridge/icebox. Carry out the above door seal checks for the fridge door and icebox door. If you have reversed the icebox door hinge side, ensure it is closing properly

Installation and ventilation

This appliance must never be installed close to heat sources, e.g. heating elements, cookers or in damp places.

- To ensure the appliance is level, you should use the height adjustable feet at the front and rear of the appliance
- The ventilation system at the bottom of the appliance must not be blocked
- Fig. 4 shows the installation requirements for your appliance. All measurements are in millimetres. Failure to install the appliance correctly can lead to increased running costs, premature failure and may invalidate the warranty provided with the appliance

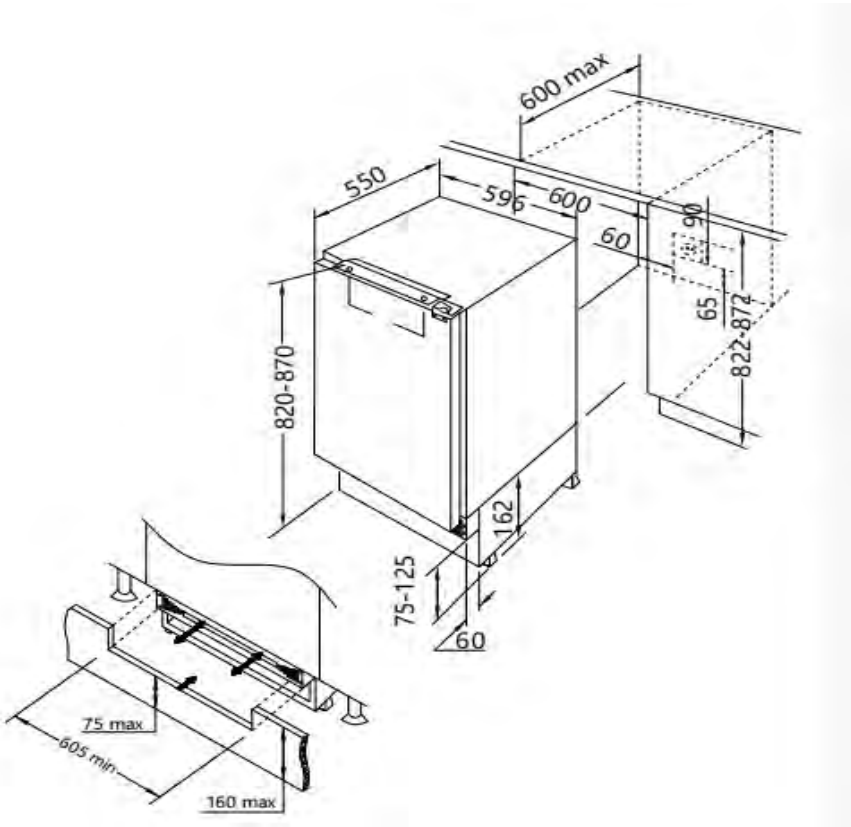

Fig. 4

Mounting the fascia doors

Fig. 6 - Fitting the decor door bracket

Remove the white decorative cover (Fig. 5) by lifting it upwards. Obtain the below measurements:

Dimension B = Measure from the underside surface of kitchen unit to the bottom of fixing bracket.

Dimension C = Measure from the underside surface of kitchen unit to the top of next unit door.

Unscrew and remove the nuts and washers from the top of the appliance door to remove the bracket.

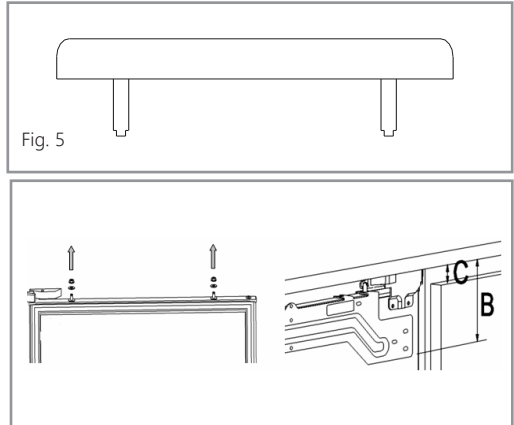

Fig. 7 - Fitting the decor door bracket

Subtract C from B and put the fixing bracket (2) in place using this measurement for the vertical position and place to the centre for horizontal position. Secure the fixing bracket (2) using screws(1).

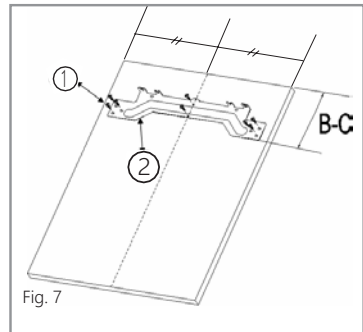

Fig. 8 - Fitting the decor door

Place the decor door onto the appliance door by inserting adjustment bolts into the slots on the fixing bracket. Locate the washers and screw the nuts onto the adjustment bolts.

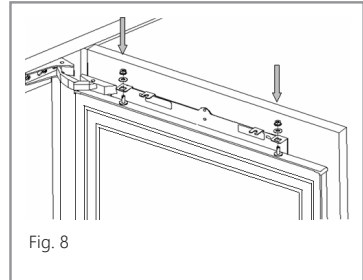
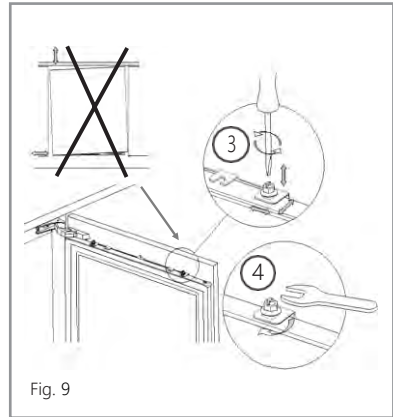

Fig.9-Aligning the decor door

Close the door and check the alignment with the other unit doors. Adjust the decor door by screwing or unscrewing the adjustment bolts (3) for vertical adjustment and by the help of the slots on the fixing bracket for other directions. Lock the screws into place(4) once the door is correctly positioned.



Fitting the decor door base fixings

With the appliance door open, locate the metal decor door base fixing brackets and screw the fixings to the decor door. You may need to remove and re-fit these brackets depending upon the decor door used.

Fitting the decorative cover

Re-fit the decorative cover, that you removed in the first step, on to the decor door fixing bracket. Check that the whole door assembly operates smoothly and that the door seal of the refrigerator is still creating a seal.

Reversing the fridge door

We recommend you seek the help of another individual to support the doors whilst performing this operation.

1. Open the door
2. Carefully prise off the white cover caps for the side that you wish to switch the hinges to
3. Loosen the screws that hold the hinges to the fridge cabinet and remove the door
4. Remove the screws that secure the hinge to the door
5. Place the door somewhere safe where it will not cause or receive damage
6. Relocate the hinges to their opposing corners as shown in Fig. 10
7. Refit the door to the hinges.

Do not turn the door upside down

8. Insert the cover caps (3) on the opposite side in the exposed holes
9. Ensure that the door seal is correct, as per page 19

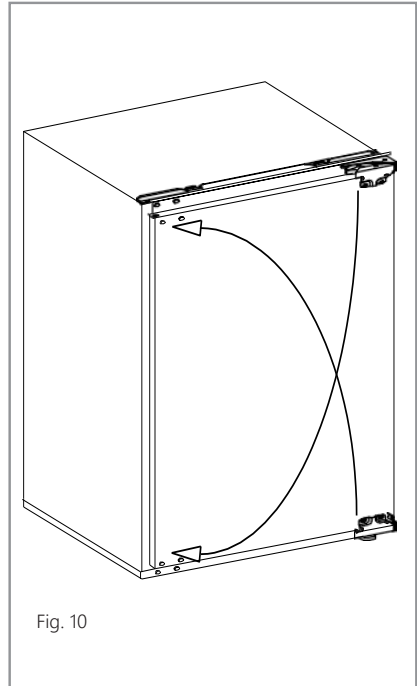

Ensuring the door seals correctly:

It is normal for the seal to be compressed after the door has been reversed. With the door closed, use a hair dryer to expand the seal and fill the gap between the door and the body of the appliance. Take care not to use the hair dryer too close to the appliance, which could damage the seal. A distance of approximately 10cm should be adequate. When completed, allow the seal and door to cool before touching them. Once done, the seal will remain in position.

Reversing the Icebox door

Remove the lower hinge piece (circled in Fig. 11) by removing the two screws holding it in place. The door will begin to drop once this has been removed so take care. Place the door somewhere safe and remove the lower hinge piece. Carefully take out the white cover caps from the opposite side.

Place these in the old hinge position holes. Remove the door latch strike plate (Fig. 12) and mirror its position on the opposite side. Re-fit the door in the new position, ensuring that the upper hinge pivot on the door goes into the recess in the top of the fridge. Latch the door over the strike plate and fit the lower hinge piece in its new position. Test that the icebox door functions properly and make any necessary adjustments.

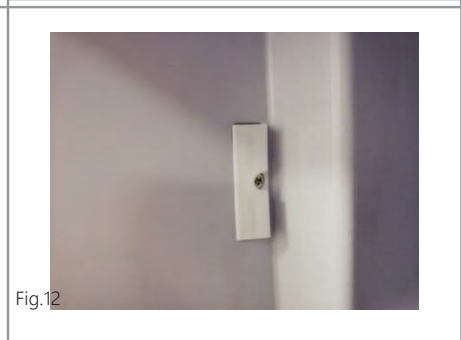
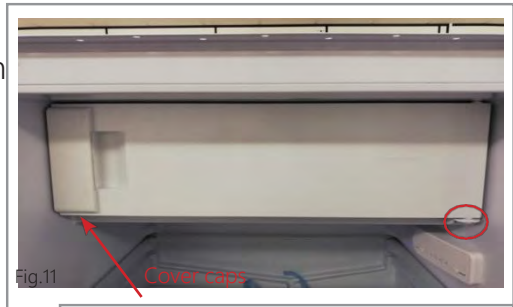



Warning; Risk of fire / flammable materials

This appliance is not intended for use by persons (including children) with reduced physical, sensory or mental capabilities, or lack of experience and knowledge, unless they have been given supervision or instruction concerning use of the appliance by a person responsible for their safety.

Children should be supervised to ensure that they do not play with the appliance.

If the supply cord is damaged, it must be replaced by the manufacturer, its service agent or similarly qualified persons in order to avoid a hazard.

WARNING: Keep ventilation openings, in the appliance enclosure or in the built-in structure, clear of obstruction.

WARNING: Do not use mechanical devices or other means to accelerate the defrosting process, other than those recommended by the manufacturer.

WARNING: Do not damage the refrigerant circuit.

WARNING: Do not use electrical appliances inside the food storage compartments of the appliance, unless they are of the type recommended by the manufacturer.

WARNING: When positioning the appliance, ensure the supply cord is not trapped or damaged.

WARNING: Do not locate multiple portable socket-outlets or portable power supplies at the rear of the appliance.

Do not store explosive substances such as aerosol cans with a flammable propellant in this appliance.

This appliance is intended to be used in household and similar applications such as

- staff kitchen areas in shops, offices and other working environments;
- farm houses and by clients in hotels, motels and other residential type environments;
- bed and breakfast type environments;
- catering and similar non-retail applications.

Please according to local regulations regarding disposal of the appliance for its flammable refrigerant and blowing gas.

If the LED lamp is damaged, it must be replaced by the manufacturer, its service agent or similarly qualified persons in order to avoid a hazard

WARNING: To avoid a hazard due to instability of the appliance, it must be fixed in accordance with the instructions

Electrical information

Warning! This appliance must be earthed.

How to connect an alternative plug

As the colours of the wires in the mains lead of this appliance may not correspond with the coloured markings identifying the terminals in your plug, proceed as follows:-

- The wire which is coloured GREEN and YELLOW must be connected to the terminal which is marked with letter (E) or by the Earth symbol \perp or coloured GREEN and YELLOW
- The wire which is coloured BLUE must be connected to the terminal which is marked with the letter (N) or coloured BLACK
- The wire which is coloured BROWN must be connected to the terminal which is marked with the letter (L) or coloured RED

If in doubt regarding the electrical connection of this appliance, consult a qualified electrician. Do not shorten the supply cable, the appliance may require removing for servicing.

N.B. Ensure that the plug socket is situated in an easily accessible place after installation.

E & O E. All instructions, dimensions and illustrations are provided for guidance only. The Manufacturer reserves the right to change specifications without prior notice.

Changing the light bulb

If the LED lighting fails in any way, it should only be replaced by an authorised service agent. In the event of light failure within your fridge please contact the Customer Care to arrange a service visit.

Climate range

The information about the climate range of the appliance is provided on the rating plate. It indicates at which ambient temperature (that is room temperature in which the appliance is working) is optimal for the operation of the appliance.

Climate class	Allowable ambient temperature
SN Extended Temperate	This refrigeration appliance is intended for use at an ambient temperature ranging between 10°C and 32°C
N Temperate	This refrigeration appliance is intended for use at an ambient temperature ranging between 16°C and 32°C
ST Sub Tropical	This refrigeration appliance is intended for use at an ambient temperature ranging between 18°C and 38°C
T Tropical	This refrigeration appliance is intended for use at an ambient temperature ranging between 18°C and 43°C

Practical tips

Due to the natural circulation of the air in the appliance, there are different temperature zones in the refrigerator chamber. The coldest area is directly above the vegetable drawers. Use this area for all delicate and highly perishable food such as:

- Fish, meat, poultry
- Sausage products, ready meals
- Dishes or baked goods containing eggs or cream
- Fresh dough, cake mixtures
- Pre-packed vegetables and other fresh food with a label stating it should be stored at a temperature of approximately 4°C

The warmest area is in the top section of the door. Use this area for storing butter and cheese.

To achieve the most effective food preservation for the longest possible time and to avoid wasting any food, position the products as shown in Fig. 1. In addition this figure illustrates the layout of drawers, baskets and shelves, which allows the most efficient use of energy.

Optimal temperature and storage conditions will extend product shelf life and optimise electricity consumption. Optimal storage temperature range should be stated on the food packaging.

Warranty Card

artusi.com.au

Worldwide Appliances Pty Limited
A.B.N. 45868077422

Distributed by Eurolinx Pty Ltd

Office:

48-50 Moore Street, Leichhardt N.S.W 2040

Post:

Locked Bag 3000, Annandale, N.S.W 2038

P: 1300 694 583

WARRANTY REGISTRATION

Your ongoing satisfaction with your artusi product is important to us. We ask that you complete the enclosed Warranty Registration Card and return it to us so that we have a record of the artusi product purchased by you.

PRIVACY

Worldwide Appliances respects your privacy and is committed to handling your personal information in accordance with the National Privacy Principles and the Privacy Act 1988 (Cth). A copy of the Worldwide Appliances Privacy Policy is available at www.artusi.com.au. Worldwide Appliances will not disclose any personal information set out in the Warranty Registration Card ("Personal Information") without your consent unless required by:

1. law;
2. any Worldwide Appliances related company;
3. any service provider which provide services to artusi or assist artusi in providing services (including repair and warranty services) to customers. Our purpose in collecting the Personal Information is

to keep a record of the artusi product purchased by you, in order to provide a better warranty service to you in the unlikely event that there is a problem with your artusi product. Worldwide Appliances may contact you at any one or more of the address, email address or telephone numbers set out in the Warranty Registration Card. Please contact artusi on 1300 694 583 should you not wish to be contacted by Worldwide Appliances.

WARRANTY

1. Warranty

Worldwide Appliances warrants that each artusi product will remain, for a period of either 12 months or 24 months of warranty. All Warranties are valid from the original date of purchase, And warranty claims must be accompanied by the proof of purchase.

24 months warranty products:

All Built-in Appliances – Limited to Ovens, Gas, Induction and Electric Cooktops, and All Rangehoods. Freestanding Cookers - Gas and Electric Models (900mm Width).

Dishwashers - Freestanding, Fully Integrated, Semi Integrated and built-in. All Wine coolers. All Dryers. Freestanding Cookers - Gas and Electric Models in 50cm, 54cm and 60cm Widths
Portable Appliances* – Benchtop Models and Portable Gas Models

2. What is not Covered by the Warranty.

The Warranty does not apply if an artusi product is defective by a factor other than a defect arising in the manufacture of the artusi product, including but not limited to:

- (a) damage through misuse (including failure to maintain, service or use with proper care), neglect, accident or ordinary wear and tear (including deterioration of parts and accessories and glass breakage);
 - (b) use for purpose for which the artusi product was not sold or designed;
 - (c) use or installation which is not in accordance with any specified instructions for use or installation;
 - (d) use or operation after a defect has occurred or been discovered;
 - (e) damage through freight, transportation or handling in transit (other than when Worldwide Appliances is responsible);
 - (f) damage through exposure to chemicals, dusts, residues, excessive voltage, heat, atmospheric conditions or other forces or environmental factors outside the control of Worldwide Appliances;
 - (g) repair, modification or tampering by the purchaser or any person other than Worldwide Appliances, an employee of Worldwide Appliances or an authorised artusi service contractor*;
 - (h) use of parts, components or accessories which have not been supplied or specifically approved by artusi.
 - (i) damage to surface coatings caused by cleaning or maintenance using products not recommended in the artusi product handbook provided to the purchaser upon purchase of the artusi product;
 - (j) damage to the base of an electric oven due to items having been placed on the base of the oven cavity or covering the base, such as aluminium foil (this impedes the transfer of heat from the element to the oven cavity and can result in irreparable damage); or
 - (k) damages, dents or other cosmetic imperfections not affecting the performance of the artusi in respect of an artusi product purchased as a "factory second" or from display
- The Warranty does not extend to light globes used in artusi products.

3. Domestic Use

Each artusi product is made for domestic use. This Warranty may not extend to artusi products used for commercial purposes.

Continued over...

4. Time for Claim under the Warranty

You must make any claim under this Warranty within twenty eight (28) days after the occurrence of an event which gives rise to a claim pursuant to the Warranty, by booking a service call on the telephone number below.

5. Proof of Purchase

Customers must retain proof of purchase in order to be eligible to make a warranty claim in respect of an artusi product.

6. Claiming under the Warranty

Customers will bear the cost of claiming under this Warranty unless Worldwide Appliances determines the expenses are reasonable, in which case the customer must claim those expenses by providing written evidence of each expense to Worldwide Appliances at the address on the Warranty Registration Card.

7. Statutory Rights

(a) These terms and conditions do not affect your statutory rights.

(b) The limitations on the Warranty set out in this document do not exclude or limit the application of the consumer guarantees set out in the Act or any other equivalent or corresponding legislation in the relevant jurisdiction where to do so would:

(i) contravene the law of the relevant jurisdiction; or

(ii) cause any part of the Warranty to be void.

(c) Worldwide Appliances excludes indirect or consequential loss of any kind (including, without limitation, loss of use of the artusi product) and (other than expressly provided for in these terms and conditions) subject to all terms, conditions and warranties implied by custom, the general law, the Act or other statute.

(d) The liability of Worldwide Appliances to you

for a breach of any express or non-excludable implied term, condition or warranty is limited at the option of Worldwide Appliances to:

(i) replacing or repairing the defective part of the artusi product;

(ii) paying the cost of replacing or repairing the defective part of the artusi product;

(iii) replacing the artusi product; or

(iv) paying the cost of replacing the artusi product.

(e) Our goods come with guarantees that cannot be excluded under the Australian Consumer Law. You are entitled to a replacement or refund for a major failure and for compensation for any other reasonably foreseeable loss or damage. You are also entitled to have the goods repaired or replaced if the goods fail to be of acceptable quality and the failure does not amount to a major failure.

8. Defects

Any part of an artusi product deemed to be defective and replaced by Worldwide Appliances is the property of Worldwide Appliances. Worldwide Appliances reserves the right to inspect and test artusi products in order to determine the extent of any defect and the validity of a claim under the Warranty.

All warranty service calls must be booked via the customer care department. The team can be contacted on 1 300 85 64 11 option 1 or customercare@eurolinx.com.au

01082016

**DON'T FORGET TO REGISTER
YOUR WARRANTY ONLINE
NOW AT www.eurolinx.support**



SCAN ME

**TO REGISTER
YOUR WARRANTY**



DISCLAIMER

Worldwide Appliances PTY LTD, trading as ARTUSI, is continually seeking ways to improve the design specifications, aesthetics and production techniques of its products. As a result alterations to our products and designs take place continually. Whilst every effort is made to produce information and literature that is up to date, this brochure should not be regarded as an infallible guide to the current specifications, nor does it constitute an offer for the sale of any particular product. Product dimensions indicated in our literature is indicative only. Actual product only should be used to define dimension cutouts. Distributors, and retailers are not agents of ARTUSI and are not authorised to bind ARTUSI by any express or implied undertaking or representation.

ARTUSI OFFICES ARE OPEN DAILY FROM 9AM-5PM AND SATURDAYS 10AM-4PM

NSW & ACT (HEAD OFFICE)
48-50 MOORE STREET
LEICHHARDT
F 02 8569 4699

VIC, TAS & SA
1211 TOORAK ROAD
CAMBERWELL
F 03 9809 2155

QLD
1/42 CAVENDISH ROAD
COORPAROO
F 07 3397 0850

WA & NT
UNIT 10/55 HOWE STREET
OSBORNE PARK
F 08 9201 9188

NZ
PO BOX 11160
SOCKBURN CHRISTCHURCH
F 03 344 5906

P: 1300 649 583

ARTUSI.COM.AU