

# *Sunbeam*

## **THE COMPACT BARISTA ESPRESSO MACHINE**

**User Guide**

EMM2900



# Contents

2 - 3	Sunbeam's Safety Precautions
4 - 5	Features of The Compact Barista
6 - 7	More details about The Compact Barista
8 - 9	Let's get you started
10-13	Your guide to café style coffee
14	Making a second coffee straight after texturing milk
15	Tips for making the perfect cup
16	Espresso extraction guide
18 - 19	Tips for milk texturing
20 - 21	Coffee styles to try
22 - 23	Customisable - shot volumes
24	Eco mode
25 - 26	Care & cleaning
27	Descaling
28 - 30	Troubleshooting guide
32	Warranty
33	Accessories available for purchase

## Sunbeam's Safety Precautions

### FOR YOUR SUNBEAM THE COMPACT BARISTA ESPRESSO MACHINE:

- Always place the unit on a flat, level surface.
- Do not place in a cabinet when in use.
- Do not operate without water in water tank. Fill water tank with filtered water. Observe the maximum filling volume is 1 litre.
- Do not remove the group handle during the espresso pour or water flow as the unit is under pressure. Removing the group handle during either of these operations can lead to a scalding or injury.
- The steam wand may become very hot during milk texturing and water flow. This may cause burns in case of contact. Therefore, avoid any direct contact with the steam wand.
- Do not allow the power cord to come into contact with the hot parts of the machine, including the warming plate and steam wand.
- Do not place hands directly under the steam, hot water or espresso pour as this can lead to a scalding or injury.
- The temperature of accessible surfaces may be high when the appliance is operating. Even after use, the heating element surface is subject to residual heat after use.
- Always switch off and unplug at power outlet before cleaning the espresso machine.
- Children should not perform cleaning and user maintenance without supervision.
- Always switch off and unplug at power outlet if there is any problem during the coffee making process.
- Do not use an appliance for any purpose other than its intended use. Injury could occur from misuse.

# Sunbeam's Safety Precautions

Sunbeam is very safety conscious when designing and manufacturing consumer products, but it is essential that the product user also exercise care when using an electrical appliance. Listed below are precautions which are essential for the safe use of an electrical appliance:

- Read carefully and save all the instructions provided with an appliance.
- Always turn the power off at the power outlet before you insert or remove a plug. Remove by grasping the plug - do not pull on the cord.
- Turn the power off and remove the plug when the appliance is not in use and before cleaning.
- Do not use your appliance with an extension cord unless this cord has been checked and tested by a qualified technician or service person.
- Always use your appliance from a power outlet of the voltage (A.C. only) marked on the appliance.
- This appliance is not intended for use by persons (including children) with reduced physical, sensory or mental capabilities, or lack of experience and knowledge, unless they have been given supervision or instruction concerning use of the appliance by a person responsible for their safety.
- Children should be supervised to ensure that they do not play with the appliance.
- The temperature of accessible surfaces may be high when the appliance is operating.
- Never leave an appliance unattended while in use.
- Do not place on top of any other appliance.
- Do not use an appliance for any purpose other than its intended use.
- Do not place an appliance on or near a hot gas flame, electric element or on a heated oven.
- Do not let the power cord of an appliance hang over the edge of a table or benchtop or touch any hot surface.
- Do not operate any electrical appliance with a damaged cord or after the appliance has been damaged in any manner. If damage is suspected, return the appliance to the nearest Sunbeam Appointed Service Centre for examination, repair or adjustment.
- For additional protection, appliance should be supplied through a residual current device (RCD) having a rated residual operating current not exceeding 30 mA;
- Do not immerse the appliance in water or any other liquid unless recommended.
- Appliances are not intended to be operated by means of an external timer or separate remote control system.
- This appliance is intended to be used in household and similar applications such as: staff kitchen areas in shops, offices and other working environments; farm houses; by clients in hotels, motels and other residential type environments; bed and breakfast type environments.

If you have any concerns regarding the performance and use of your appliance, please visit the Sunbeam Website or contact Sunbeam Consumer Care - details are on the back page. Ensure the above safety precautions are understood.

## Important Instructions - retain for future use

تأكد من تفهم احتياطات السلامة المذكورة اعلاه

請務必理解上述的安全預防措施。

Assurez-vous que les précautions ci-dessus relatives à la sécurité sont bien comprises

Versichern Sie sich, dass die obenstehenden Sicherheitsmaßnahmen Verstanden werden

Βεβαιώστε πως οι παραπάνω προφυλάξεις ασφαλείας γίνονται κατανοητές

Pastikan bahwa tindakan-tindakan keselamatan seperti di atas dimengerti anda

Accertatevi che le suddette norme di sicurezza siano comprese a dovere

上記の注意事項をよくお読みになり、安全を御確認ください

Уверете се дека погоре споменатите мерки на претпазливост се добро разбрани

Asegúrese de que las precauciones de seguridad precedentes sean bien comprendidas

کاری بکنید کہ احتیاطهای بالا حتماً درک بشوند

ต้องแน่ใจว่า ข้อควรระวังเรื่องความปลอดภัยข้างต้นเป็นที่เข้าใจกันดี

Yukarda belirtilen güvenliğin önlemlerinin anlaşılığınızdan emin olunuz

Xin kiểm soát rằng những biện pháp làm an toàn kể trên được hiểu rõ

# Features of The Compact Barista Espresso Machine

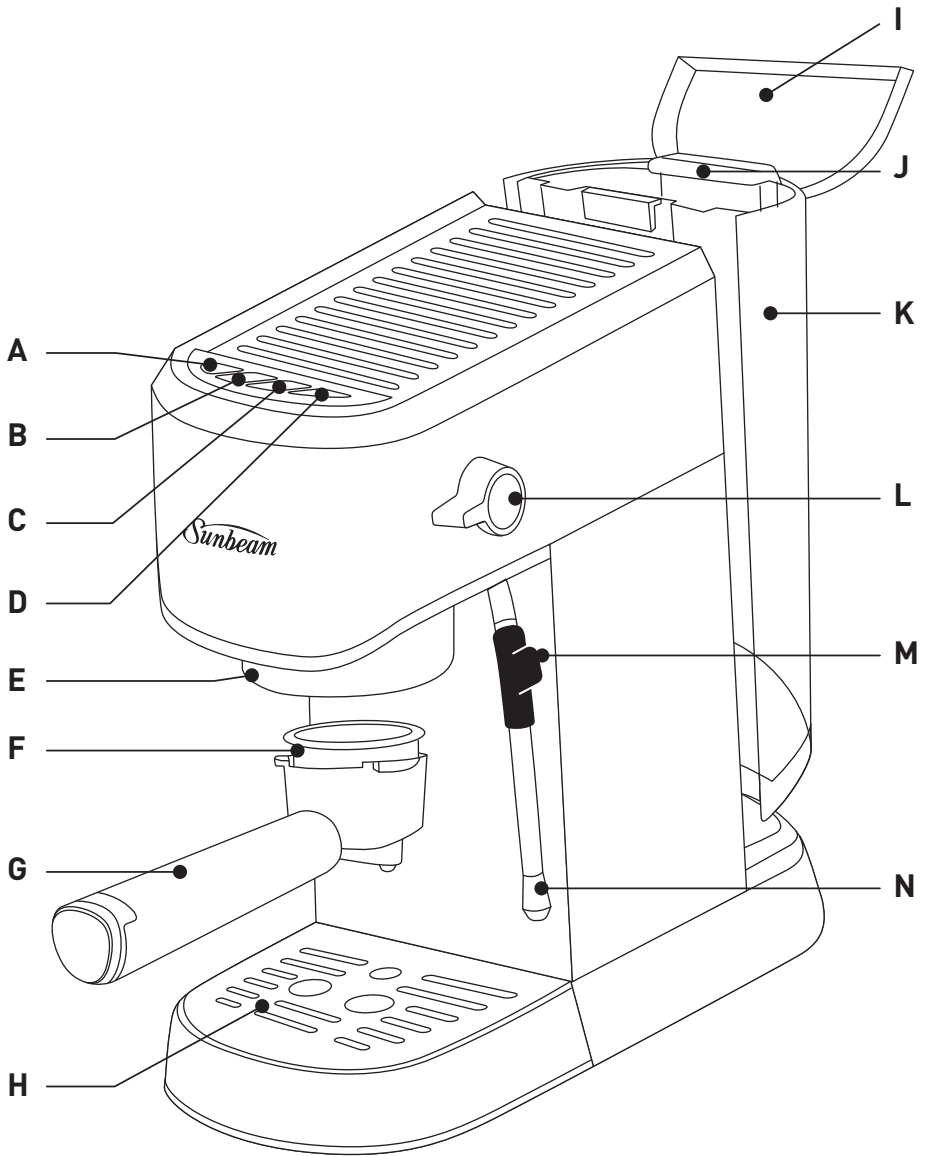

# Features of The Compact Barista Espresso Machine

## A. Standby

Press button to turn on the machine. The 1 CUP, 2 CUP and STEAM lights will pulse to indicate it is heating up.

## B. 1 CUP

Preset single shot volume.

## C. 2 CUP

Preset double shot volume.

## D. Steam

Press button for steam.

## E. Group head

## F. Filter basket

## G. Group handle

## H. Removable drip tray and grill

## I. Water tank lid

## J. Water tank handle

## K. Water tank

1L capacity.

## L. Dial

Turn the dial to switch between steam and hot water.

## M. Steam wand handle

## N. Steam wand

## Accessories

- Group handle
- Dual wall filter baskets (1 CUP, 2 CUP)
- Tamper measuring spoon
- Milk jug

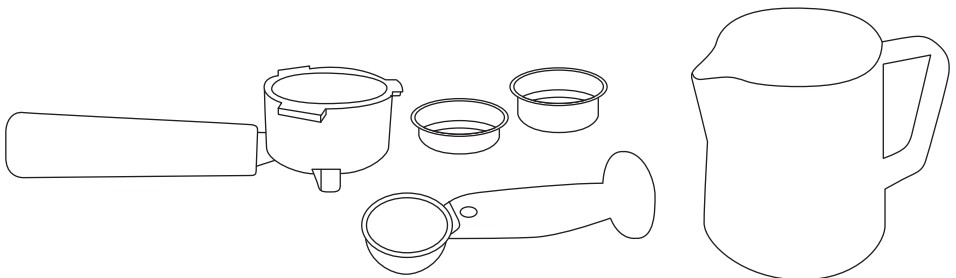

More details about The Compact Barista



## More details about The Compact Barista



### Thermoblock Fast Heating System

The thermoblock ensures quick heat up, and a precise water temperature for the best coffee extraction, and milk texturing.

### 15 BAR Pump

The thermoblock works in conjunction with the pump to deliver the correct water temperature at the correct pressure for complete extraction of oils, coffee solids and aroma.

The 15 BAR pump is fitted with a pressure relief system, to limit the pressure to 15 bar (for protection from over-pressure).

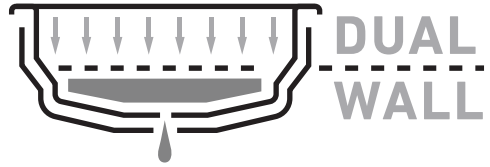

### Italian Crema System

Dual wall filter baskets create additional back pressure creating a subtle aeration for a great espresso extraction and steady pour. They ensure a rich velvety espresso with a signature layer of golden crema. Dual wall filter baskets are designed for use with pre-ground coffee, however they can also be used with freshly ground coffee.

### Auto Shot and customisable volumetric control

*Right quantity of espresso in your cup*

- Auto Shot is the easiest way to create a great espresso. Press the 1 CUP or 2 CUP buttons to pour the right amount.

# Let's get you started

Everything you need to know after unboxing your new coffee machine.

## Step 1. Remove packaging

- Ensure all packaging has been removed.

## Step 2. Position machine

- Ensure the machine is positioned onto a dry, stable, flat & horizontal benchtop.

## Step 3. Remove the plug at the bottom of the water tank.



## Step 4. Wash & dry parts

- Wash the parts listed below in warm water with a mild detergent:
  - Milk jug
  - Tamper measuring spoon
  - 1 CUP & 2 CUP dual wall filter baskets
  - Water tank
  - Group handle
- Rinse and allow thorough air drying.

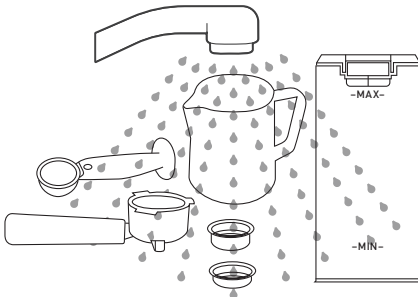

**Note:** Make sure that the water tank is clean and free of any debris, as any fine particles can block the water flow.

**Important:** This priming step must be completed prior to first use or if the machine has been inactive over a long period of time.

## Step 5. Preparing to prime machine

- Fill water tank
  - Fill the water tank with cold water to the MAX level.
  - Use filtered water for best results.



- Power
  - Ensure that the dial is in the OFF position.
  - Insert the power plug into a 230-240V AC power outlet and switch the power on.
  - Press the STANDBY button to turn on the machine.



- The 1 CUP, 2 CUP & STEAM buttons will pulse to indicate the machine is heating up.
- When the machine is ready, the STANDBY, 1 CUP, 2 CUP and STEAM buttons will illuminate. The machine is now ready to use.

# Let's get you started

## Step 6. Prime espresso machine

- Place 2 large cups under the group head and steam wand.

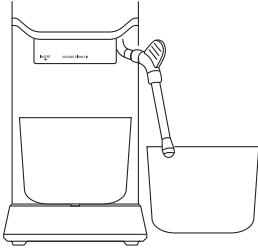

- Press the 2 CUP button and water will start flowing from the group head.

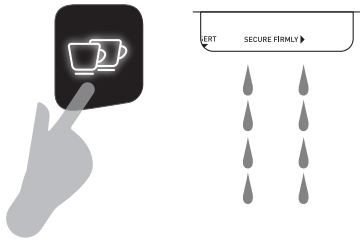

- Allow water to run through until it stops.

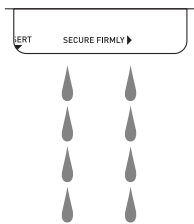

- Turn dial to the HOT WATER position.

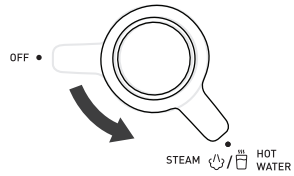

- Allow hot water to run through for 20 seconds.

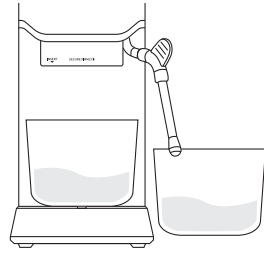

- Return dial to OFF position.

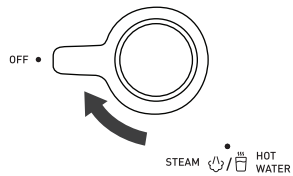

# Making your first café quality coffee

## 1. Check water tank is full

- Barista Tip: use filtered water for best results.

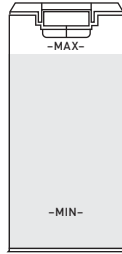

## 2. Start up

- Press the STANDBY button. The 1 CUP, 2 CUP & STEAM buttons will pulse to indicate the machine is heating up.
- When STANDBY, 1 CUP, 2 CUP & STEAM buttons are illuminated, the machine is ready for use.



- Quarter fill cup with hot water.

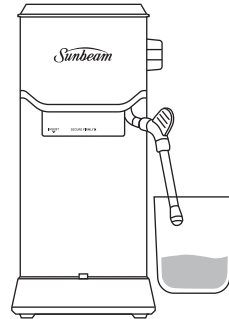

- Return dial to OFF position.

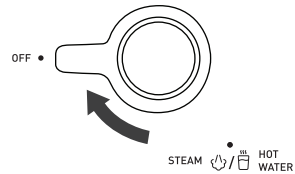

- Empty cup after 20 – 30 secs.

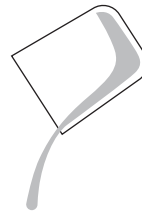

## 3. Warm up with hot water

- Position steam wand in cup.
- Turn dial to HOT WATER.

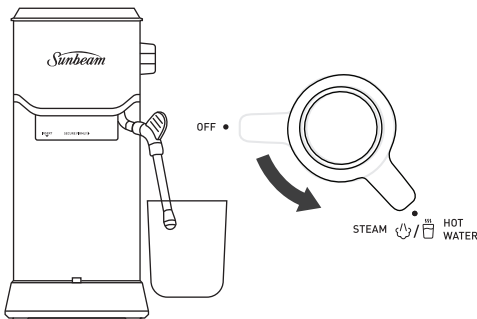

## 4. Select filter baskets

- Select either the 1 CUP or 2 CUP filter basket.
- Insert filter basket into group handle.

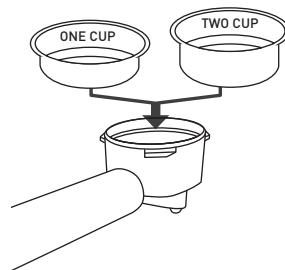

# Making your first café quality coffee

## 5. Warm group head, group handle & filter basket

- Insert group handle into group head.
- Press 2 CUP button.
- Wipe filter basket with a dry cloth

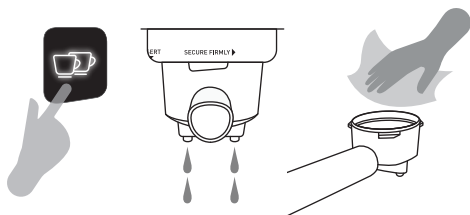

**Note:** Turning the group handle to the centre position might be tight for the first few uses.

## 6. Dose coffee grinds.

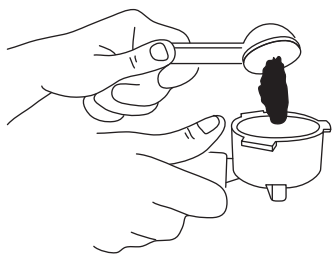

**Barista Tip:** For café style coffee, always use good quality coffee beans. Coffee beans have the best flavour between 5 – 20 days after roasting.

## 7. Tamp

- Evenly tamp grinds to level indicated.

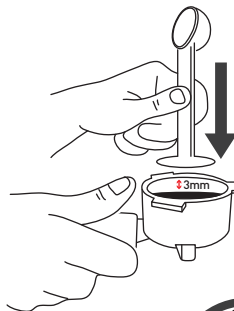

## 8. Wipe excess grinds

- Wipe away any excess grinds to clear edges.

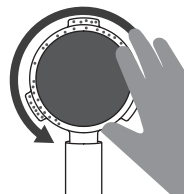

## 9. Insert group handle

- Insert group handle into group head.
- Group handle should be in the centre position.

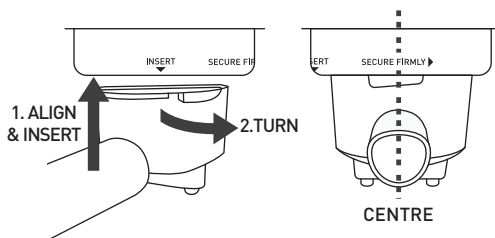

## 10. Position cup

- Position cup under group handle.

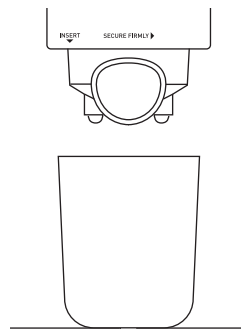

# Making your first café style coffee

## 11. Espresso extraction

Press either:

- 1 CUP button = 30mL shot
- 2 CUP button = 60mL shot

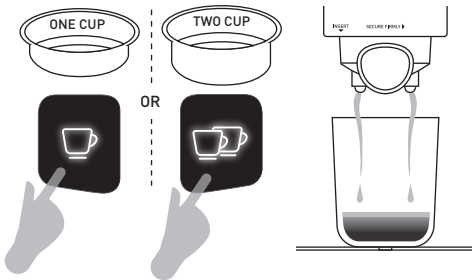

**Important:** To make more than one latte or cappuccino, first make all the espressos then at the end prepare the steamed milk for the latte or cappuccino.

## 12. Prep milk jug

- Fill jug with cold milk just below the bottom of the spout.

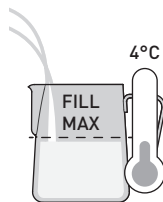

## 13. Before milk texturing

- Press STEAM button.
- The STEAM button will pulse to indicate the steam is heating up.
- Once STEAM button is illuminated, turn the dial to STEAM to warm up steam wand. Return dial to OFF position.

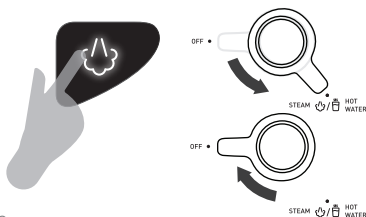

## 14. Position steam wand

- Insert steam wand at 12 o'clock, tip at 3 o'clock, finger width from edge and just below the surface of the milk.

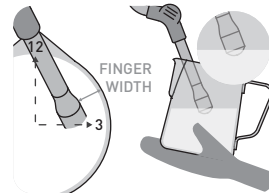

## 15. Milk texturing

- Turn dial to STEAM to start texturing milk.
- Texturing makes a smooth hissing noise.
- Check milk is moving in a whirlpool action.

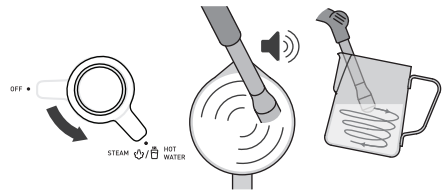

- As milk level rises, lower jug to keep tip just below surface.
- When desired microfoam is achieved, immerse steam wand half way.

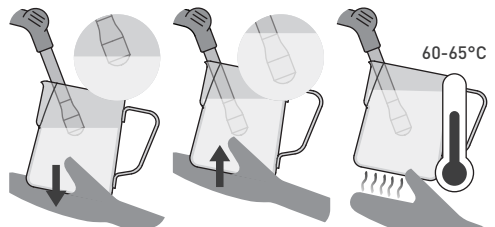

# Making your first café style coffee

- Return dial to OFF position.
- Remove steam wand from jug.

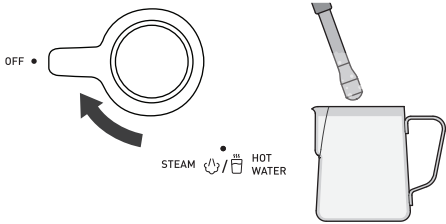

## 16. Clean and purge steam wand

- Wipe steam wand and tip with a damp cloth.
- Turn dial to HOT WATER for 3 seconds to purge the steam wand

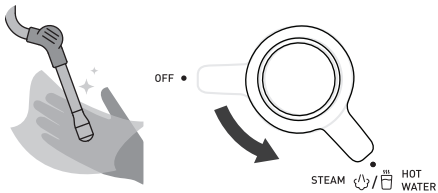

- Milky water will come out of the steam wand.
- Return dial to OFF position.

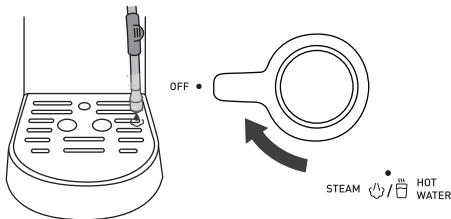

## 17. Pour milk

- Tap jug to release larger air bubbles.
- Swirl jug to blend milk and create a silky texture.
- Pour milk in one steady motion.

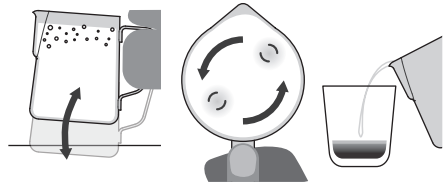

## 18. Remove coffee cake

- Turn group handle and remove from group head.
- Remove used coffee cake from group handle.

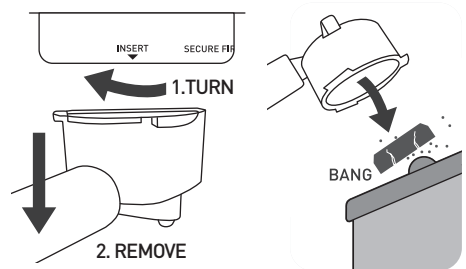

# Making your first café style coffee

## 19. Making a second coffee straight after texturing milk

**Important:** To make coffee again immediately after texturing milk, the thermoblock must be cooled by following these steps:

- Press either the 1 CUP, 2 CUP or STEAM button (all buttons will illuminate).



- Place a cup under the steam wand.

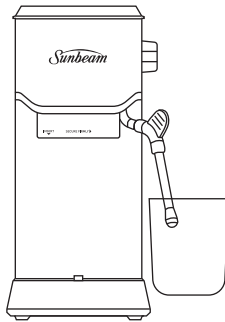

- Turn the dial to the HOT WATER position.

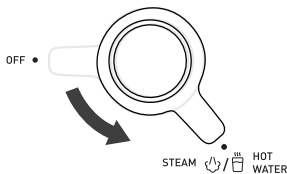

- Leave on until hot water comes out.

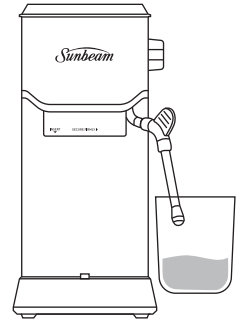

- Return dial to OFF position.
- The coffee machine is now ready for use.

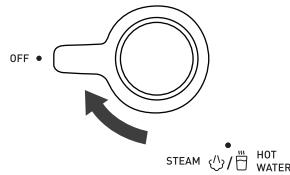

## 20. Wash parts

- Wash parts with warm water.



## 21. Drip tray clean up

- Check if drip tray needs emptying.
- Empty water from drip tray and wash in warm soapy water.

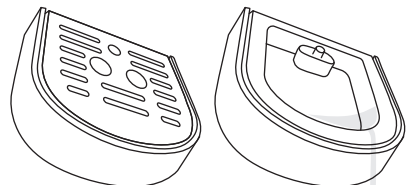

# Tips for café style coffee

The way the espresso pours will tell you everything. Look out for:

## 1. Extraction time

Extraction time provides a good indicator of the quality of the pour. The optimum time per shot varies between different bean types and between freshly & pre-ground coffee grinds. However, in general, the time will be between 20-30 seconds for both 1 CUP & 2 CUP shots.

## 2. Type of extraction

- **Optimum Extraction.** A quality pour has a steady flow with a consistency similar to that of warm honey. The resulting crema is dark golden. The sweetest flavours and oils have been extracted creating a rich tasting espresso.
- **Under Extraction.** The pour is quick and light in colour, the resulting crema is thin with a creamy light brown colour which quickly dissipates. This occurs when too little of the essential oils, flavours and colours from the coffee grinds have been extracted. This creates a sour tasting espresso.
- **Over Extraction.** There may be no pour, or it may be slow and drip throughout the entire pour. The resulting crema is very dark. This occurs when too much of the essential oils, flavours and colours from the coffee grinds have been extracted. This creates a bitter tasting espresso.

## 3. Look for colour change

The optimum shot contains 3 elements: -

- **Heart:** At the base - starts out dark brown.
- **Body:** Blends with the heart - becomes a rich caramel with reddish reflections.
- **Crema:** The layer on top of the body - dark golden.



## 4. Grinds

You may need to vary the coffee grind size when using different beans.

**Important:** Ensure beans or pre-ground grinds are fresh. Old pre-ground grinds and old beans, no matter the grind size, will not produce a good tasting espresso.

## 5. Tamp force

Coffee should be 3mm below top of filter after tamping.

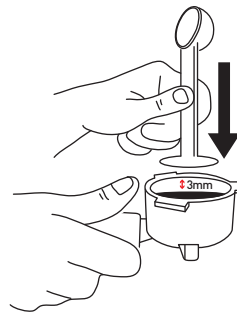

## 6. Filter baskets



- Dual wall filter baskets

Supplied with The Compact Barista, these work well with both pre-ground coffee grinds and freshly ground coffee grinds.



## Espresso extraction guide

There are extraction variations from bean to bean, and everyone's taste is different. Use the below as a guide to improve your espresso technique, so it's just right for you.

	UNDER EXTRACTION	OPTIMUM EXTRACTION	OVER EXTRACTION
			
<b>Pour</b>	Extraction too fast Pours for under 15 sec	Steady-flow extraction Pours for 20-30 sec	Extraction too slow Pours for over 35 sec
<b>Colour</b>	Pale brown Crema-light brown	Rich caramel Crema-dark golden	Very dark brown Crema-dark brown
<b>Taste</b>	Sour, acidic, watery	Rich, sweet, vibrant	Bitter, dry, grainy
<b>Grind Size</b>	Too coarse Use a finer grind	Just right	Too fine Use a coarser grind
<b>Dosage</b>	Not enough grinds Use more grinds	3mm below the top of the filter basket after tamping	Too many grinds Use less grinds
<b>Tamp</b>	Not enough tamp force Tamp firmer	Just right-firm force 10-15Kg of force	Too much tamp force Tamp lighter



# Tips for milk texturing

Milk texturing is the steaming of milk.

## Key elements of textured milk

Milk that has been textured correctly has a thick, rich microfoam with a silky sheen. Texturing involves both heating and aerating milk using steam. Vital elements include positioning of the steam wand, when to adjust the milk jug position and reaching the correct temperature. Use the below steps to help you create café style microfoam.

### 1. Fill milk jug

Add cold milk around 4°C into a chilled clean stainless steel jug. Fill to the bottom of the spout.

**Note:** The volume of milk will increase or 'stretch' during texturing, so don't overfill the jug.

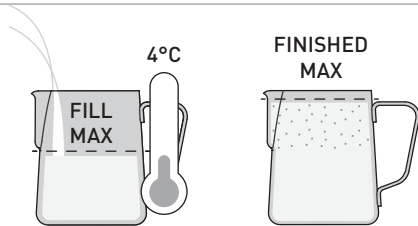

### 2. Steam warm up

For best milk texturing results every time, ensure steam has warmed up before texturing milk. Steam is ready when STEAM light is fully on.

### 3. Position

Place the steam wand in the jug spout at the 12 o'clock position, with the steam wand tip in the milk at the 3 o'clock position. Keep the steam wand tip just under the surface of the milk. This will create a whirlpool action.

### 4. Sound

How air is introduced to the milk determines the consistency of the foam. If large gulps of air are added to the milk, the foam will have large bubbles. Introducing air to the milk in a controlled, gentle fashion indicated by a gentle hissing sound, will ensure the milk has fine aerated microfoam.

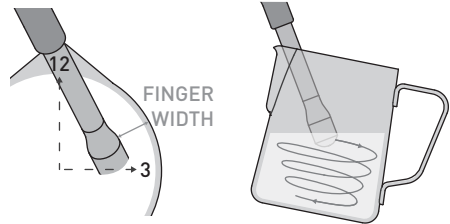

### 5. Keeping steam tip position

As the steam heats and textures the milk, the milk will stretch causing the level of the milk in the jug to rise. As this happens follow the level of the milk by lowering the jug, keeping the steam wand tip just below the surface.

**Barista Tip:** milk texturing sounds

- Gurgling - tip not deep enough, raise jug.
- Smooth Hissing - just right for latte.
- Screeching - tip too deep, lower jug.

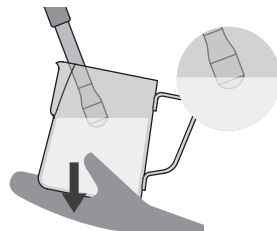

**Note:** Some adjustments to technique will be required when using non-dairy milk.

# Tips for milk texturing

## 6. Amount of foam

Create the amount of microfoam you want. Cappuccinos traditionally have more microfoam than flat whites.

[See *Coffee styles to try* on next page]

## 7. Immerse tip

After creating the desired amount of foam, immerse the steam wand half way deep into the milk. This heats all the milk and pulls in milk instead of air. This ensures the milk and foam are blended together, making it denser and smoother.

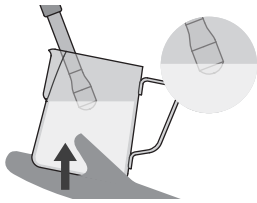

### Barista Tip: Milk temperature

- Under - if not heated long enough, it will be warm with little texture.
- Optimum - see table below.
- Over - if heated for too long it will start to boil around 72°C and will have a burnt taste with all texture lost.

MILK	TEMPERATURE
Full and Skim	60-65°C
Almond	55-65°C
Soy and Oat	55-60°C
Coconut	65-70°C

**Note:** Above recommendations might vary from one milk brand to another and depending on your taste preference.

## 9. Tap and swirl the jug

Pour from the milk jug into your cup in one steady motion.

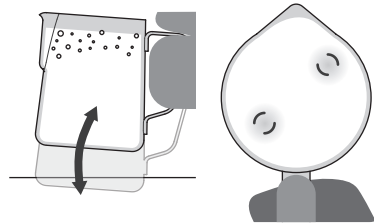

## 10. Clean & purge steam wand

After steaming milk, wipe the steam wand with a clean damp cloth to remove any milk residue.

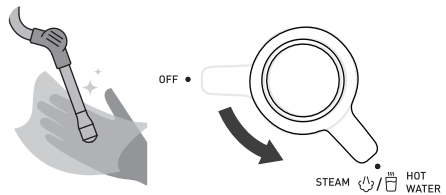

Position the steam wand over the drip tray. Immediately purge the steam wand by turning the dial to the HOT WATER position for 3 seconds.

Return the dial to the OFF position.

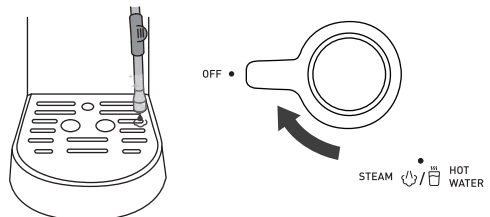

## Coffee styles to try



### Espresso (Short Black)

Espresso is a concentrated, full bodied coffee with a stable layer of crema on top. An espresso is the foundation of all café coffee.

- Espresso glass (90mL)
- Single or double shot of espresso (30mL-60mL)



### Ristretto

A ristretto is an extremely short espresso, distinguished by its intense flavour, aftertaste and its thin crema on top.

- Espresso cup (30mL)
- Half a single shot of espresso (15mL)

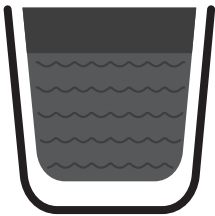

### Long Black (Americano)

A standard espresso with hot water added. The hot water is added first so that the crema is maintained.

- Cup (190mL)
- Hot Water (to preference)
- Single or double shot of espresso (30mL-60mL)

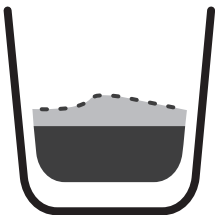

### Con Panna

Con Panna, Italian for 'with cream', made up of an espresso topped with lightly whipped cream. It can also be dusted with cinnamon or drinking chocolate.

- Cup (190mL)
- Single or double shot of espresso (30mL-60mL)
- Lightly whipped cream - dusted cinnamon.

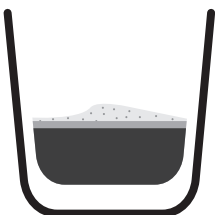

### Macchiato

Macchiato, Italian for 'to stain or mark'. Traditionally served as a standard espresso with a dash of cold or textured milk and a small dollop of textured foam into the middle of the crema.

- Espresso glass (90mL)
- Single or double shot of espresso (30mL-60mL)
- Dash of cold or textured milk and small dollop of textured foam.

## Coffee styles to try



### Flat White

An espresso with textured milk and a thin layer of textured foam milk on top. The wider cup will create the slim layer of foam, the signature of the flat white.

- Wide cup (190mL)
- Single or double shot of espresso (30mL-60mL)
- Textured milk and foam.



### Latte

An espresso with textured milk and a finger width layer of textured foam milk on top. The narrower cup will create the thicker layer of foam.

- Glass or Cup (220mL)
- Single or double shot of espresso (30mL-60mL)
- Textured milk and foam.



### Cappuccino

An espresso with  $\frac{1}{3}$  steamed textured milk, topped with  $\frac{1}{3}$  creamy foam and a dusting of chocolate.

- Cup (190-240mL)
- Single or double shot of espresso (30mL-60mL)
- $\frac{1}{3}$  Textured milk,  $\frac{1}{3}$  textured foam - dusted with chocolate.



### Mocha

Made in a similar way to a cappuccino but with the addition of drinking chocolate. Simply stir the chocolate into the espresso prior to adding the steamed textured milk and foam.

- Cup or tall glass (190-240mL)
- Single or double shot of espresso (30mL-60mL)
- Drinking chocolate [to preference]
- $\frac{1}{3}$  Textured milk,  $\frac{1}{3}$  textured foam.

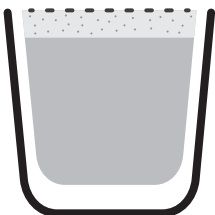

### Babyccino

Steamed textured milk with a layer of foamed milk. It can also be dusted with chocolate.

- Small cup (90mL)
- No shot of espresso
- Textured milk and textured foam - dusted with chocolate.

## Customisable - shot volumes

The Compact Barista features Auto Shot Volumetric Control. It pours just the right amount of espresso then automatically stops.



- 1 CUP - Pours 1 shot espresso - 30mL
- 2 CUP - Pours 2 shots espresso - 60mL

You can adjust the pour volume to suit how you like your coffee.

### Preparing for shot programming

#### • Check water tank

Ensure there is enough water in the water tank.

#### • Power

Ensure that:

- The dial is in the OFF position.
- The power plug is inserted into the outlet and turned on.
- The machine is ON and in the ready state.

#### • 1 CUP – shot volume program

- Insert a 1 CUP filter basket into the group handle. Fill with coffee grinds and tamp.

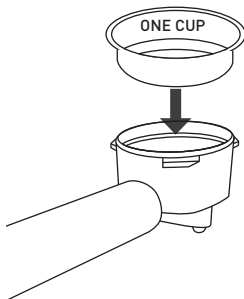

- Place the group handle into the group head.

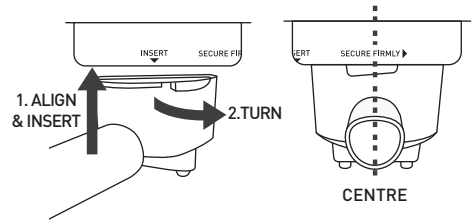

- Hold and press the 1 CUP button for 3 seconds until the machine beeps.
- Press the 1 CUP button again.
- Espresso will start to pour and the 1 CUP button will pulse.
- When you reach your desired single shot volume, press the 1 CUP button again.
- The new single shot volume has been programmed.
- The programming mode has finished and will return to the ready state.



---

**Note:** Single shot volumes can be adjusted between 25mL and 60mL.

---

## Customisable - shot volumes

### • 2 CUP – shot volume program

- Insert a 2 CUP filter basket into the group handle. Fill with coffee grinds and tamp.

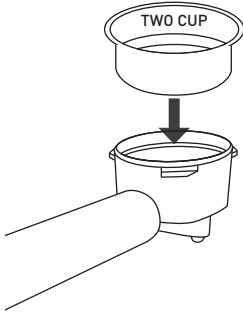

- Place the group handle into the group head.

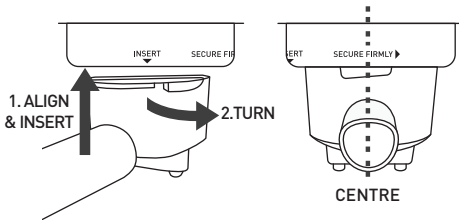

- Hold and press the 2 CUP button for 3 seconds until the machine beeps.
- Press the 2 CUP button again.
- Espresso will start to pour and the 2 CUP button will pulse.
- When you reach your desired double shot volume, press the 2 CUP button again.
- The new double shot volume has been programmed.
- The programming mode has finished and will return to the ready state.



**Note:** Double shot volumes can be adjusted between 60mL and 110mL.

### • Restore default single shot & double shot volumes

- Press and hold the 1 CUP and 2 CUP buttons for 3 seconds until the machine beeps.
- The machine has now been restored to the default volumes.

## Eco mode

### **Eco mode**

- After 20 minutes of inactivity, the machine will automatically power off.
- The pump will automatically stop after pumping 215mL of water.
- The pump will automatically stop once the steam function has been running for over 3 minutes.

## Care and cleaning

The espresso making process involves extracting oils out of coffee grinds. Deposits of grinds and oils build up over time affecting the taste of the coffee and operation of the espresso machine. Purging water through the group head and steam wand before and after making coffee is the easiest way to keep your machine clean.

**Important:** Below parts are NOT DISHWASHER SAFE:

- Group handle
- Drip tray
- Tamper measuring spoon
- Water tank

**CAUTION:** To prevent damage to the appliance do not use alkaline cleaning agents when cleaning the exterior. Use a soft cloth and a mild detergent.

### Cleaning tablets

Sunbeam Espresso Machine Cleaning Tablets (EMA0025CL) are available for purchase from Sunbeam. Details are on the back page.

### Cleaning drip tray

Empty the drip tray when required, if the red water level indicator appears through the grill, empty the drip tray immediately.

#### • Weekly

Clean the drip tray and grill with warm water and a little non-abrasive washing up liquid, rinse and dry.

**Note:** Over time it is normal for the inside of the drip tray to be stained by the oils in the coffee grinds.

### Cleaning exterior of machine

Wipe over the machine with a damp cloth and wipe dry. Do not use alkaline cleaning agents, abrasives or metal scourers, as these will scratch the exterior surface.

**Important:** Do not immerse the machine in water.

### Cleaning group handle & filter basket

#### • Every time

Wash after each use by rinsing them with warm water under the tap.

#### • Regular intervals

In warm soapy water using a mild detergent.

### Cleaning group head

#### • Every time

Run water through before making an espresso.

#### • Weekly

- Purge water through by pressing the 1 CUP button.
- Wipe around the inside rim with a damp cloth & brush.



### Cleaning filter baskets

#### • 2-3 months

- Soak the filter basket overnight in the milk jug with warm water & add one Sunbeam Cleaning Tablet.

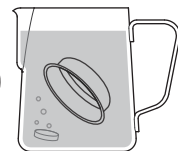

- In the morning rinse the jug & filter basket under running water ensuring all traces of the cleaning tablet has been removed.
- Place filter basket into group handle (without coffee) & insert into group head.
- Press the 1 CUP button.
- Water will pour through.

## Care and cleaning

### • Unblocking filter baskets

If the dual wall filter basket becomes clogged with coffee grinds:

- Insert a pin in the exit hole.

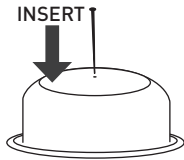

- Place filter basket into group handle (without coffee) & insert into group head.
- Press the 1 CUP button.
- Water will pour through.
- Repeat if needed.

### Cleaning steam wand

#### • Every time

- Wipe the steam wand with a damp cloth.
- After texturing milk purge the steam wand by turning the dial to HOT WATER for 3 seconds.

#### • 2-3 months

- Soak the steam wand overnight in the milk jug with warm water & add one Sunbeam Cleaning Tablet.

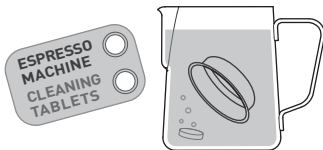

- In the morning remove the jug & rinse ensuring that all traces of the solution have been removed.
- Wipe steam wand & tip with a damp cloth ensuring that all traces of the cleaning tablet have been removed.
- Run hot water through the steam wand for 40 seconds.

#### • Unblocking steam wand

- Insert a pin up the steam wand tip
- Run hot water through the steam wand.

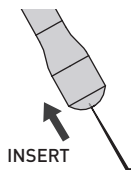

### Steam wand remains blocked

- Unscrew the steam wand tip & soak overnight in the milk jug with warm water & add one Sunbeam Cleaning Tablet.

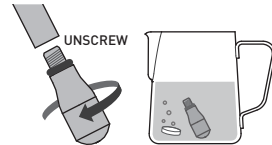

- In the morning rinse the jug & steam wand tip under running water ensuring all traces of the cleaning tablet have been removed.
- Use a pin to clean the steam tip.
- Screw the steam wand tip back into the steam wand arm.
- Run hot water through the steam wand for 40 seconds.

### Group head rubber seal

A rubber seal is located in the group head and creates a seal against the filter basket when making an espresso.

**Important:** When your espresso machine is not being used, we recommend that you do not leave the group handle inserted into the group head, as this will reduce the life of the seal.

Over time this seal loses its elasticity and may require replacement. The seal may need replacing when watery espresso leaks from around the group head, or if the group handle feels loose when fully rotated to the centre position.

**Note:** Contact Sunbeam should you think that the group head seal needs replacing. Do not attempt to change the seal without first consulting Sunbeam.

## Descaling

After continued use, your machine may develop a build up of mineral deposits and will require occasional descaling. We recommend descaling your machine every 4-6 months, although this period will depend on the hardness of water and frequency of use.

**Important:** Your machine will let you know when it's time to descale. The STANDBY, 1 CUP, 2 CUP and STEAM buttons will flash 5 times. You will need to descale your machine and reset it to cancel the descale warning.

### Descaling solution

Sunbeam Descaler (EMA0015CL) are available for purchase from Sunbeam. Details are on the back page.

### Preparing for descaling

#### • Fill water tank with solution

- Fill water tank to the MAX level and add one Sunbeam Descaler sachet. Allow powder to fully dissolve.

#### • Place containers

- Place 2 large cups under the group head and steam wand.

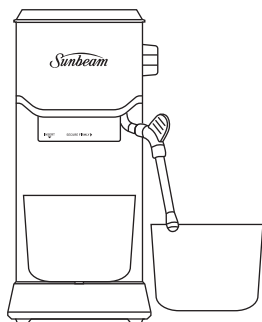

#### • Power

Ensure that:

- The power plug is inserted into the outlet and turned on.
- The machine is ON and in the ready state.

#### • Descaling

1. Press the 2 CUP button and allow the descaling solution to pour through. Then turn the dial to HOT WATER and allow approximately 100mL of water to pour through.
2. Press the STANDBY button to turn off the machine.
3. Leave the descaling solution in the machine for 5 minutes.
4. Press the STANDBY button to turn on the machine.
5. Repeat Step 1 three times.
6. Discard the descaling solution and rinse the water tank with water.
7. Fill the water tank with water to the MAX level.
8. Repeat Step 1 two times with water.
9. After descaling, cancel the descaling warning by simultaneously pressing the 1 CUP, 2 CUP and STEAM buttons for 3 seconds.

#### • Cancel the descale warning

- After descaling, cancel the descale warning by simultaneously pressing the 1 CUP, 2 CUP and STEAM buttons for 3 seconds.

## Troubleshooting guide

Problem	Possible cause	What to do
<b>Group handle comes off during espresso pour</b>  <b>Espresso squirts out of the group head during pour</b>  <b>Espresso trickles down the side of the group handle</b>	Group handle is not attached correctly, or has not been tightened sufficiently.	Ensure all three tabs of the group handle are fully inserted into the group head and rotate to the centre position.
	Coffee grind is too fine.	Change to a coarser grind.
	Coffee grinds tamped too hard.	Tamp the grinds more lightly.
	Top edge of filter is not free of coffee grinds.	Clean around the top edge of the filter and wipe the group head clean.
	The group head is dirty.	Wipe with a damp cloth. Clean the seal including the bayonet corner areas with a brush to remove grinds.
Group head rubber seal is damaged or worn.	Contact Sunbeam Customer Care. Details are on the back page.	
<b>No coffee pours</b>	No water in the water tank.	Fill water tank with water. Run water through the machine without a filter basket to ensure it is fully primed.
	Group head may be blocked.	See <i>Descaling</i> section, page 27.
	The dual wall filter baskets may be blocked.	Use a pin to unblock the filter basket.
	The coffee grounds are too fine or tamped down too hard.	Empty the filter basket and rinse under water to clean. Wipe the group head with a cloth. Refill the filter with grinds and tamp.
	Thermoblock needs to be cooled.	Turn dial to HOT WATER until hot water comes out. Return dial to the OFF position.
<b>Coffee pours out in drips</b> (Over Extracted)	Grinds are too fine.	Change to a coarser grind.
	Coffee tamped too hard.	Tamp the grinds more lightly.
	Machine has scale build up.	See <i>Descaling</i> section, page 27.
<b>Espresso does not have any crema</b> (Under Extracted)	Beans are old or pre-ground grinds are dry.	Use fresh beans and grinds. Be sure to store pre-ground grinds in an airtight container.
	Grinds not compacted enough.	Tamp more firmly
	Grinds too coarse.	Use a finer grind coffee.
<b>Uneven cup filling</b>	Uneven tamping or obstruction in the pouring spouts.	Ensure coffee is tamped evenly and check there is nothing obstructing the pouring spouts.
<b>Spent coffee cake is wet</b>	Dual wall filter baskets can keep the coffee cake wet.	Keep group handle in group head until milk texturing is finished. This will give more time for the water to dissipate.

## Troubleshooting guide

Problem	Possible cause	What to do
Espresso tastes burnt	Type of coffee being used.	Try different brands of coffee.
Coffee is too cold	Milk may not be heated enough.	Ensure that milk is heated properly during texturing, but be sure not to heat too much and boil the milk. See <i>Tips for milk texturing</i> section, pages 18-19.
No steam from the steam wand	The STEAM button light is not illuminated.	Allow the thermoblock to heat up before steaming.
	Steam wand tip is blocked.	See <i>Care and cleaning</i> , pages 25-26.
	No water in the tank.	Fill water tank with water. Run hot water through the steam wand to ensure water flows.
Not enough froth when texturing	Milk may not be fresh.	Ensure the milk being used is fresh.
	Milk temperature is too warm.	Ensure you start texturing with milk that is around 4°C.
	Type of jug being used.	For best texturing results use a chilled stainless steel milk jug.
	Milk has been boiled.	Start again with fresh, chilled milk. Heat till the jug can only be held for approximately 3 seconds, 60-65°C.
	The milk is making bubbles rather than microfoam.	Ensure the steam wand tip is positioned correctly. It should be just below the surface of the milk. Tap the jug on the benchtop when finished to release larger trapped air bubbles.
	Milk is not taking in enough air.	Keep the steam wand tip just under the surface of the milk. This will help to introduce air to the milk to create microfoam.
Pump makes an unusual noise	No water in water tank.	Fill the water tank.
	Water tank not correctly positioned.	Place the water tank firmly into the back of the unit.
	Red plug from the packaging may still be inserted.	Remove the red plug found at the base of the water tank.

## Troubleshooting guide

Problem	Possible cause	What to do
<b>Water leaks from the bottom of the machine</b>	Too much water in the drip tray.	Empty drip tray.
	The coffee machine is damaged.	Contact Sunbeam Customer Care. Details are on the back page.
<b>Machine does not power on</b>	The power outlet is not plugged in.	Insert the power plug into a 230-240V AC power outlet and switch the power on. Press the STANDBY button to turn on the machine.
<b>1 CUP &amp; 2 CUP button flashes rapidly</b>	After dispensing more than 215mL of hot water, the dial needs to be returned to the OFF position.	Turn dial to OFF position.
	The dial is not returned to the OFF position after machine was cooled down.	
	The machine is on but the dial is not in the OFF position.	
	Thermoblock needs to be cooled.	Turn dial to HOT WATER for a few seconds.
<b>STEAM button flashes rapidly</b>	The steam function has been running continuously for more than 3 minutes.	Turn dial to OFF position.
<b>1 CUP, 2 CUP &amp; STEAM buttons flash 5 times</b>	Machine needs to be descaled.	Refer to <i>Descaling</i> section, page 27.
<b>STANDBY, 1 CUP, 2 CUP &amp; STEAM buttons flash continuously</b>	The coffee machine is faulty.	Contact Sunbeam Customer Care. Details are on the back page.
<b>Machine beeps</b>	Dial is not in the OFF position.	Return the dial to the OFF position.









This Sunbeam product is covered by a 12 month replacement or repair warranty, which is in addition to your rights under the Australian Consumer Law (if your product was purchased in Australia) or New Zealand Consumer Guarantees Act (if your product was purchased in New Zealand).

Upon receipt of your claim, Sunbeam will seek to resolve your difficulties or, if the product is defective, advise you on how to obtain a replacement or refund.

To assist us in managing warranty claims, we recommend you register your product as soon as practicable after purchase by creating a MySunbeam account on our website and uploading a copy of your original receipt.

In order to make a claim under our warranty, you must have the original proof of purchase documentation for the product and present it when requested (if not already uploaded to our website).

Should your product develop any defect within 12 months of purchase because of faulty materials or workmanship, we will replace or repair it, at our discretion, free of charge. A product presented for repair may be replaced by a refurbished product of the same type rather than being repaired. Refurbished parts may be used to repair the product.

Our replacement or repair warranty only applies where a defect arises as a result of faulty material or workmanship during the warranty period. Your warranty does not cover misuse or negligent handling (including damage caused by failing to use the product in accordance with this instruction booklet), accidental damage, or normal wear and tear.

Your warranty does not:

- cover freight or any other costs incurred in making a claim, consumable items, accessories that by their nature and limited lifespan require periodic renewal (such as filters and seals) or any consequential loss or damage; or
- cover damage caused by:
  - power surges, power dips, voltage supply problems, or use of the product on incorrect voltage;

- servicing or modification of the product other than by Sunbeam or an authorised Sunbeam service centre;
- use of the product with other accessories, attachments, product supplies, parts or devices that do not conform to Sunbeam specifications; or
- exposure of the product to abnormally corrosive conditions; or

- extend beyond 3 months if the product is used in commercial, industrial, educational or rental applications.

**The benefits given to you by our warranty are in addition to other rights and remedies under law in relation to the product.**

**In Australia our goods come with guarantees that cannot be excluded under the Australian Consumer Law. You are entitled to a replacement or refund for a major failure and for compensation for any other foreseeable loss or damage. You are also entitled to have the goods repaired or replaced if the goods fail to be of acceptable quality and the failure does not amount to a major failure.**

**Our goods also come with guarantees that cannot be excluded under the New Zealand Consumer Guarantees Act.**

If your warranty claim is not accepted, we will inform you and if requested to do so by you, repair the product provided you pay the usual charges for such repair. You will also be responsible for all freight and other costs.

Should your product require repair or service after the warranty period, contact your nearest Sunbeam service centre. For a complete list of Sunbeam's service centres, visit our website or call our customer care line for advice on: 1300 881 861 in Australia, or 0800 786 232 in New Zealand.

**Should you experience any difficulties with your product during the warranty period, please contact Sunbeam Customer Care:**

**Australia**  
www.sunbeam.com.au  
1300 881 861

**Suite 1, Level 1,  
13 Lord Street,  
Botany NSW 2019  
Australia**

**New Zealand**  
www.sunbeam.co.nz  
0800 786 232  
**Level 6, Building 5,  
Central Park,  
660-670 Great South Road  
Greenlane, Auckland  
New Zealand**

## Accessories available for purchase

CONTACT SUNBEAM CUSTOMER CARE:  
AUS: 1300 881 861    NZ: 0800 786 232

1 Cup

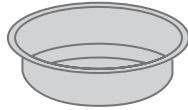

EM28008

2 Cup

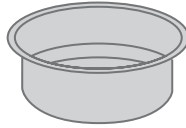

EM28009

**Bang Bang**

Coffee grinds disposal bin

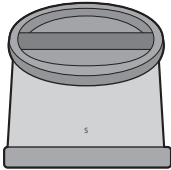

EM0100

**Large milk jug**

600mL capacity

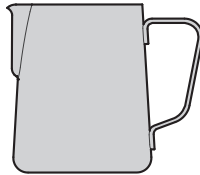

EM0260

**Mini Bang Bang**

Coffee grinds disposal bin



EMA0900

### Cleaning & Descaling

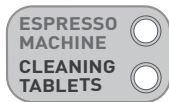

EMA0025CL



EMA0015CL

Visit Sunbeam website to see full Espresso Machine range & accessories available.  
[www.sunbeam.com.au](http://www.sunbeam.com.au)    [www.sunbeam.co.nz](http://www.sunbeam.co.nz)

# Sunbeam

## Need help with your appliance?

Contact our Customer Care Team or visit our website for information and tips on getting the most from your appliance.

### AUSTRALIA

Visit: [www.sunbeam.com.au](http://www.sunbeam.com.au)

Phone: 1300 881 861

Mail: Suite 1, Level 1,  
13 Lord Street,  
Botany NSW 2019  
Australia

### NEW ZEALAND

Visit: [www.sunbeam.co.nz](http://www.sunbeam.co.nz)

Phone: 0800 786 232

Mail: Level 6, Building 5, Central Park,  
660-670 Great South Road,  
Greenlane, Auckland



Newell Australia Pty Ltd | ABN 68 075 071 233  
Sunbeam is a registered trade mark.

Due to continued product improvements, product illustrations and photographs in this User Guide may differ slightly from the actual product.